

Spring type model CPC is the pallet clamp mounted on a Pal system. Dual surface contact on tapered surface and seating surface ensures solid and stable clamping against loads from high rpm or heavy-duty cutting. Solution for high machining accuracy along with maximum productivity.

Pallet clamp

model **CPC**



Locate ring model CPS-E

Spring clamp model CPC-A

Spring clamp 7MPa

Highly rigid pallet clamp and repeated positioning accuracy of 3 μm with dual surface contact

Pal system

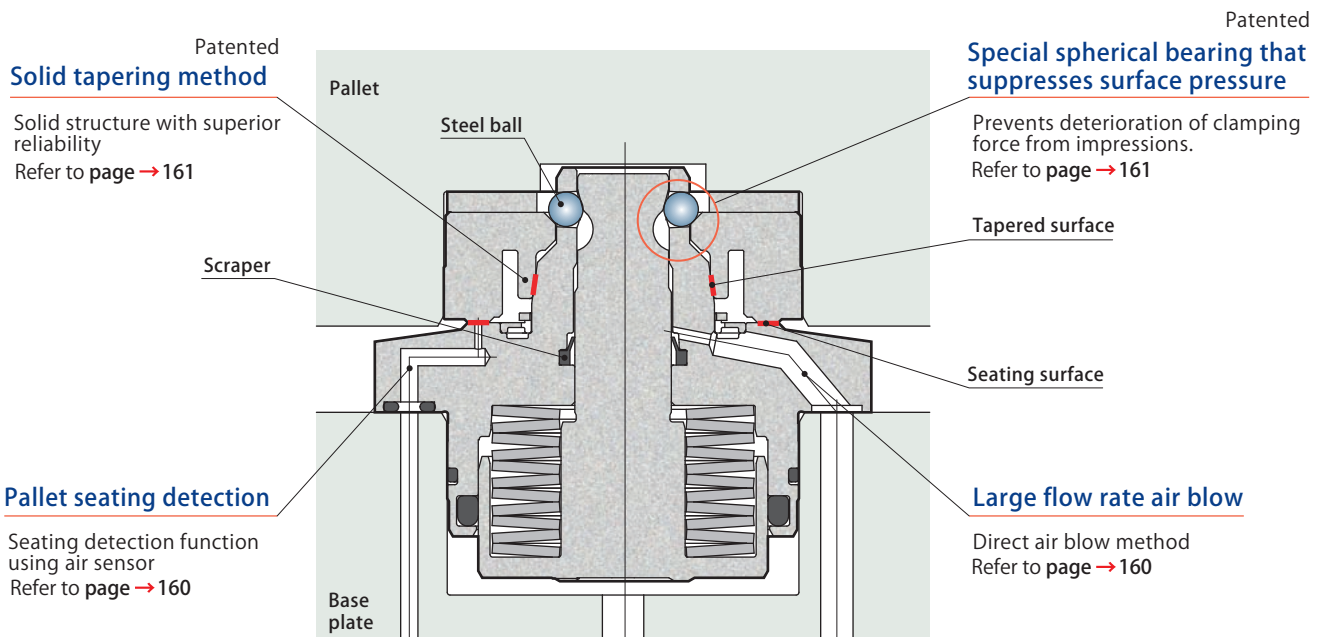

Model		CPC-A03H	CPC-A06H	CPC-A10H	CPC-A16H	CPC-A25H	CPC-A40H
Clamping force	(kN)	4.0	6.0	10.0	16.0	25.0	40.0
Max. allowable load (including pallet)	Horizontal mounting (kN)	3.0	8.0	15.0	25.0	35.0	50.0
	Vertical mounting (kN)	0.5	1.5	2.5	4.0	5.0	7.5
Driving force	Clamp	Spring					
	Unclamp	Hydraulic pressure					

Hydraulic type model CPH is the pallet clamp mounted on a Pal system. Dual surface contact on tapered and seating surface ensures solid and stable clamping against loads from high rpm or heavy-duty cutting. Solution for high machining accuracy along with maximum productivity.

Pallet clamp
model **CPH**



Highly rigid pallet clamp and repeated positioning accuracy of 3 μm with dual surface contact

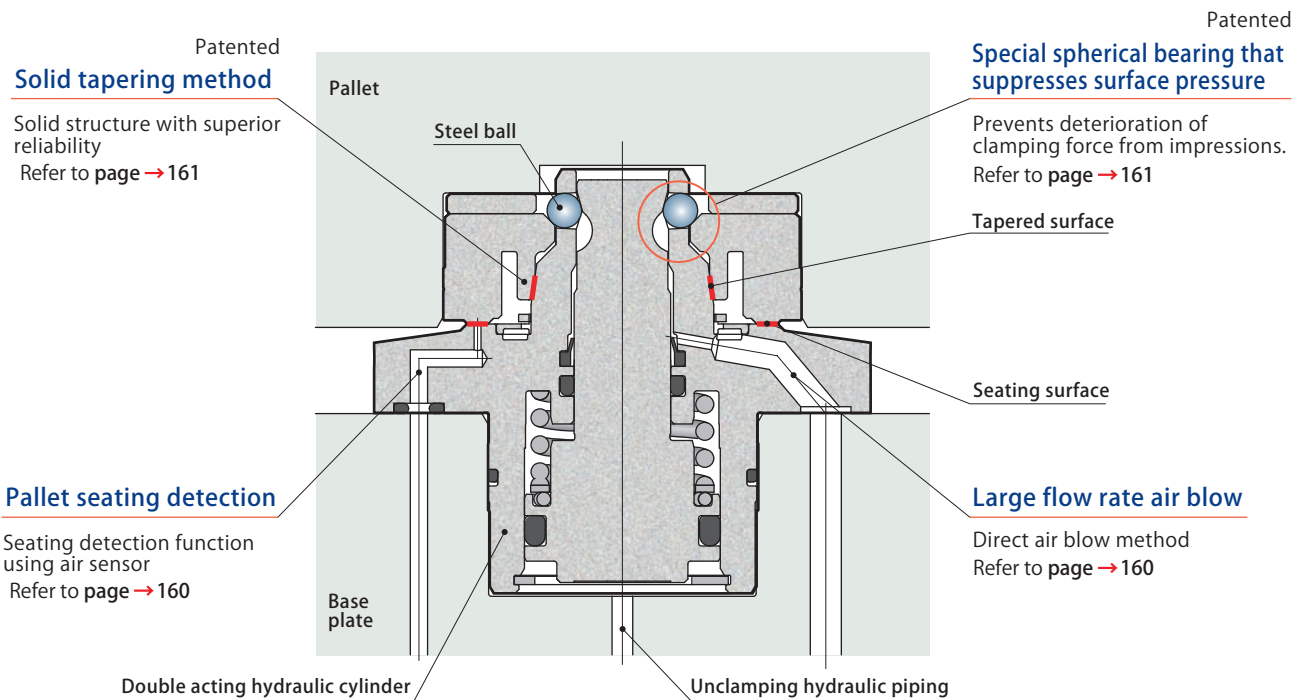

Pal system

Model		CPH-A03H	CPH-A06H	CPH-A10H	CPH-A16H	CPH-A25H	CPH-A40H
Clamping force	(kN)	4.0	6.0	10.0	16.0	25.0	40.0
Max. allowable load (including pallet)	Horizontal mounting (kN)	3.0	8.0	15.0	25.0	35.0	50.0
	Vertical mounting (kN)	0.5	1.5	2.5	4.0	5.0	7.5
Driving force	Clamp	Hydraulic pressure					
	Unclamp	Hydraulic pressure					

Pallet setting

Bring the pallet above the base plate. After positioning, lower the pallet.

Pallet descends along guides (A) & (B) and stops after coming into contact with piston rod upper surface (C), making pallet setting easy.

Furthermore, since locate ring does not come into contact with seating surface of pallet clamp, damages on seating surface can be prevented during pallet exchanges.

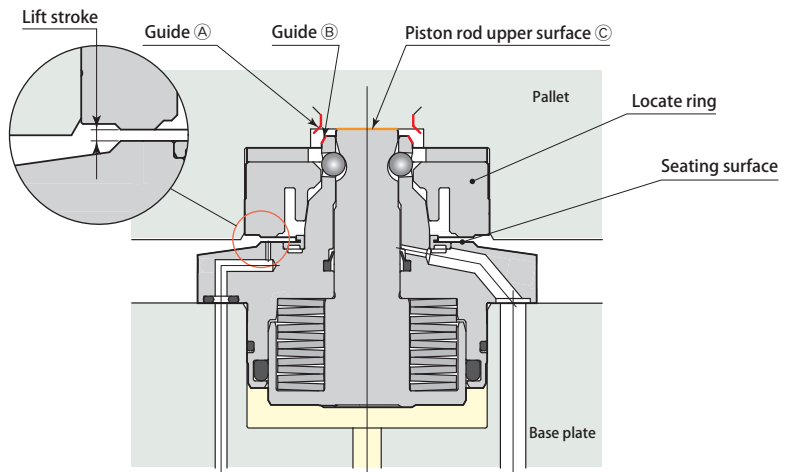

XY axes positioning

When the unclamping hydraulic pressure is released, piston rod goes down by spring force* and radially extends the steel balls, pulling down the locate ring. Solid taper built-in the locate ring and taper cone at pallet clamp come into contact.

* : Applied for model CPC (spring type).
For model CPH, hydraulic force.

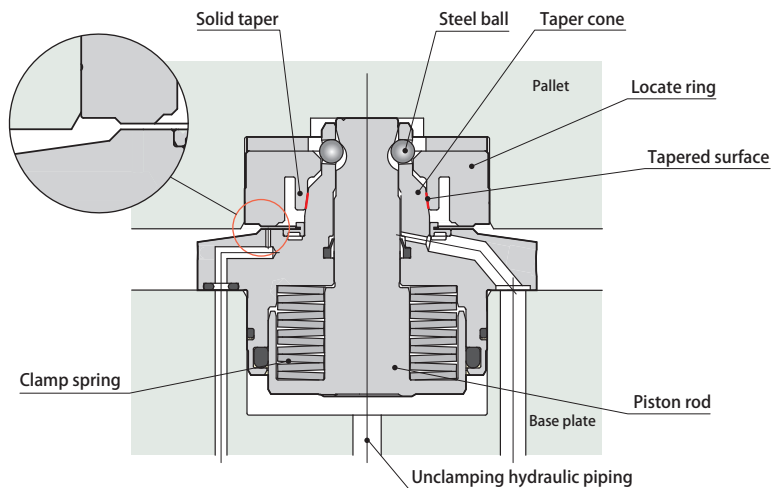

XYZ-positioning (completed clamping)

Solid taper that is attached to tapered surface of taper cone is expanded and deformed in radial direction to firmly position X axis and Y axis.

Locate ring is attached to seating surface and positions Z axis. The positioning of X, Y and Z axes by tapered surface and seating surface completes the XYZ positioning (dual surface positioning).

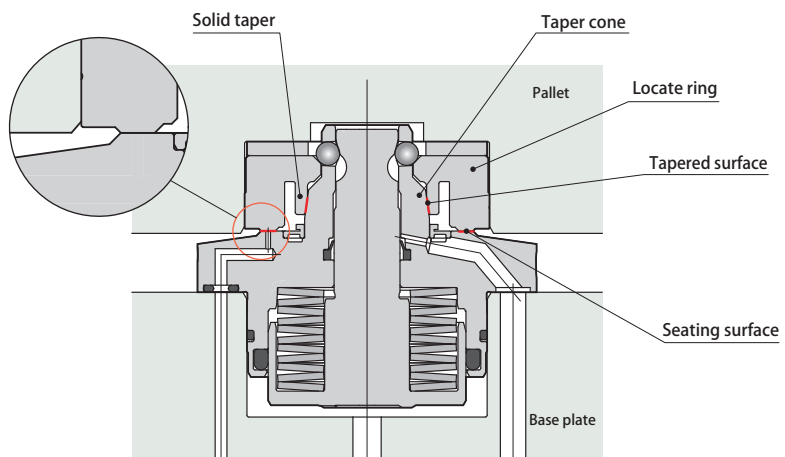

Highly accurate repeated positioning and retention of accuracy

- Air blows out of wide slits laid out over circumference to tapered surface and seating surface directly for ensuring prevention of foreign substances.
- Since seating detection function is provided, it is possible to prevent operation with incomplete clamping due to insertion of metal chips.
- Rust proofing has been implemented to locate ring in order to prevent rusting while pallet is in storage or on standby.
- All cutting and turning components are machined using high precision grinding machines. Internal and external surfaces have been simultaneously machined in temperature controlled rooms.
- Completed components are under strict quality control program in order to maintain horizontal accuracy of pallet surfaces when eventually mounted on machines.

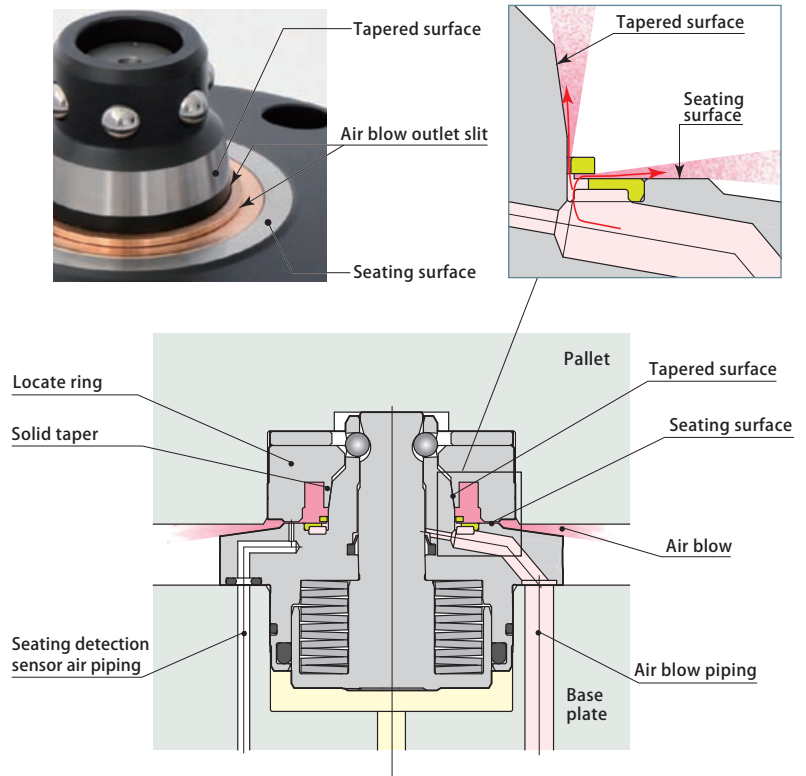

Taper angle that withstands large cutting thrust force

Pallet clamp has tapered surface angle that is close to perpendicular, which allows for stable clamping with minimal impact from thrust exerted during cutting process. This is particularly effective in inhibiting chatter when cutting process at higher locations on the pallet, which improves processing conditions for high-speed cutting and heavy duty cutting.

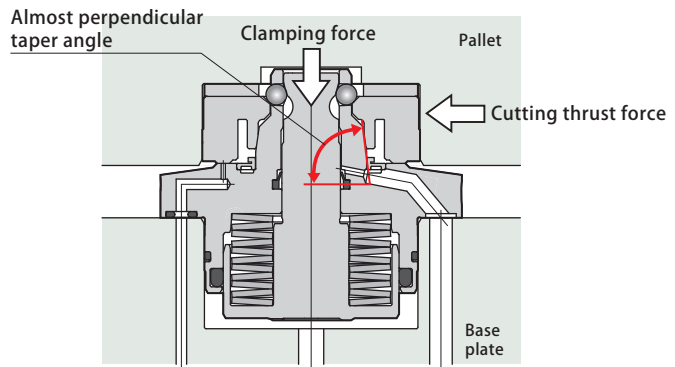

Rectangular flange (made to order)

A rectangular flange, created by cutting out mounting flange portion of pallet clamp body, is available (made to order). Inquire for details.

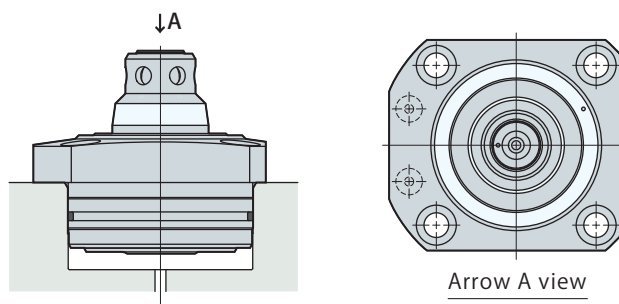

Solid tapering method with superior durability and accuracy for repeated positioning

- Solid taper type locate ring has no sliding portion for its positioning structure. Advantageous in terms of durability as well as in keeping the initial repeatability for a long time.
- When positioning X & Y axes, the taper portion evenly and elastically deforms outwards to offer highly accurate positioning. Furthermore, the taper portion has no slits, eliminating accuracy issues relating to positioning due to intrusion of metal chips into slits.
- Elastic deformation of taper portion is conducted evenly due to the integrated ribs that are evenly distributed in the radial direction providing high clamping rigidity.

Solid tapering method model CPS-E

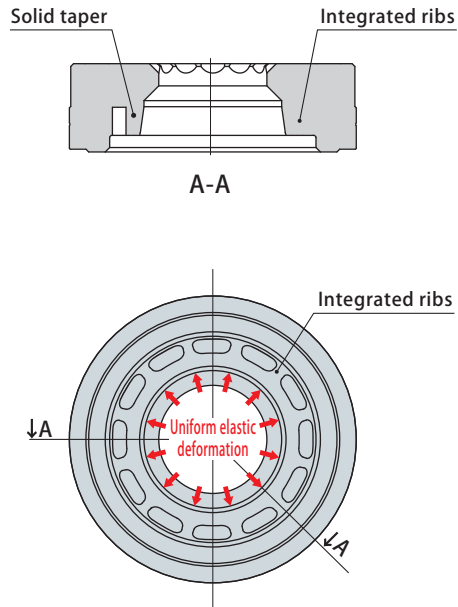

Specialized design reduces surface contact pressure and prevents deterioration of clamping force

- Pallet clamp enhances output of clamp piston and firmly secures pallet. Steel ball contacting portions, where high surface pressure is exerted, have been designed in a special form that prevents indentation marking, which can deteriorate the clamping force, thereby making it possible to firmly fix pallets over long periods of time.

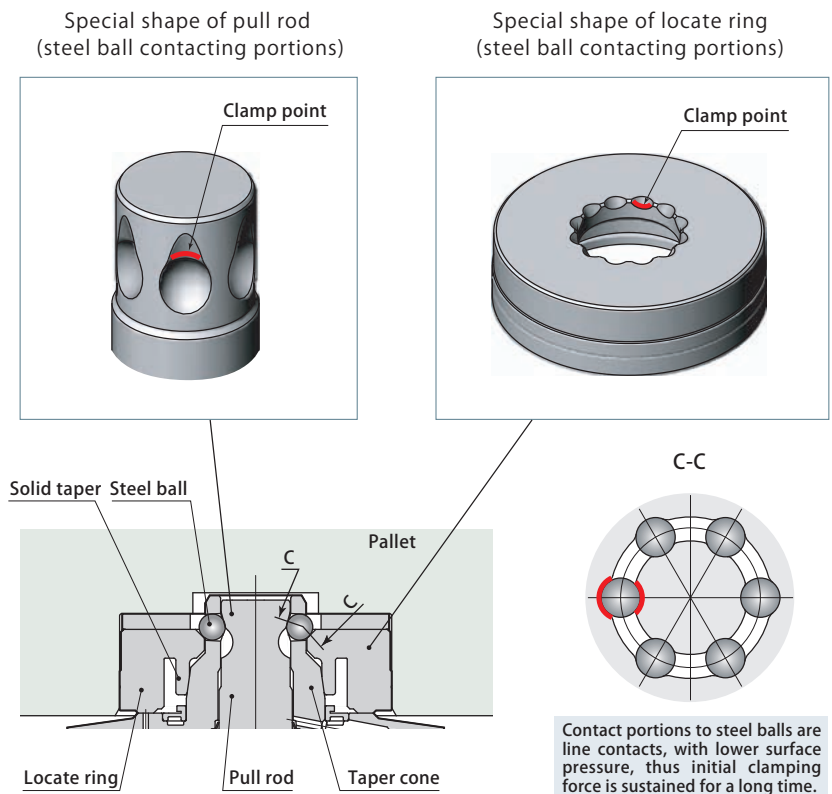

Exchanges of fixtures and workpieces are easy with Pal system

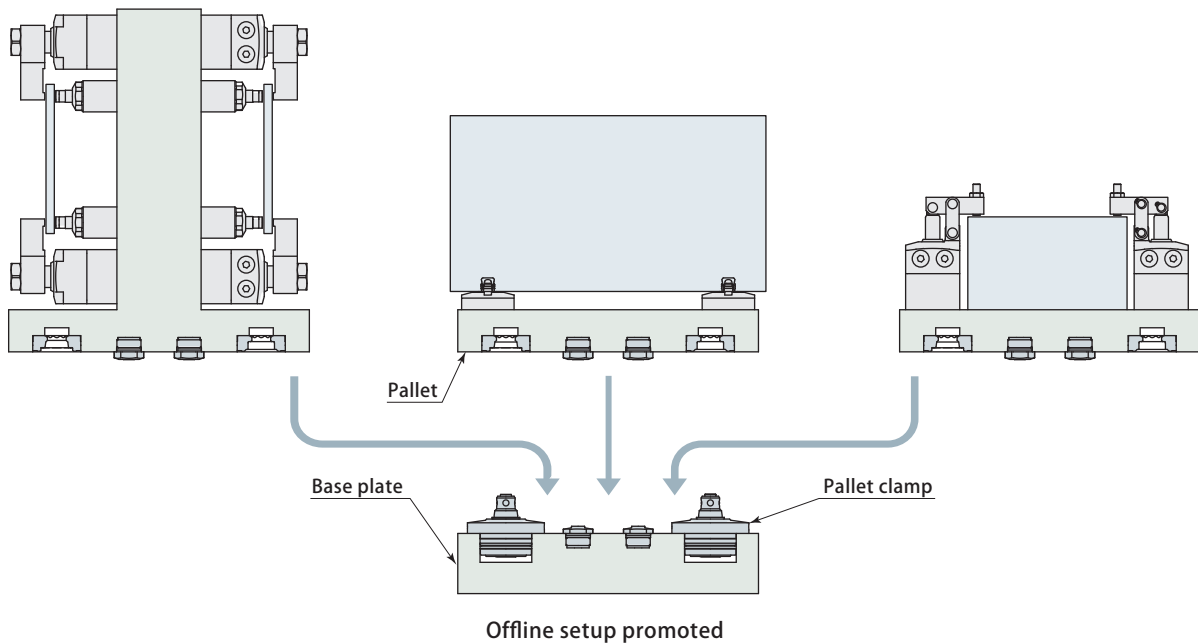

- Implementation of Pal system makes it possible to perform setting of workpiece on fixtures of machine table accurately and significantly reduces setup time that was previously necessary for alignment.

Multifaceted machining with high accuracy is easy

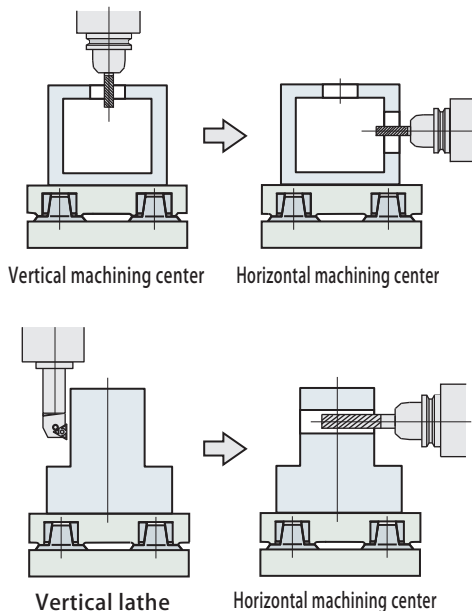

- Since workpieces do not have to be dismantled from pallets, continuous operations through multiple machines are possible. Highly accurate, multifaceted machining is possible with the Pal system.

Process division is easy (pallet transfer method)

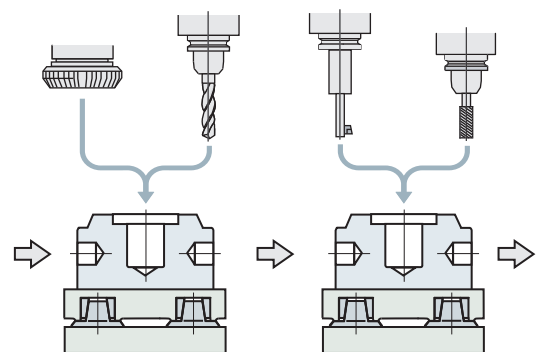

- Highly accurate positioning of Pal system makes it possible to distribute processes. This advantage allows a flexible allocation of machining process, which needs a very high accuracy. This flexibility makes it easier to unify tact time among all machines, leading to even distribution of load among machines to raise productivity.
- With pallet transfer method, mixed production of workpieces can be done easily.
- Workpieces are fixed onto the pallet before transferring, thus clamp time is short and problems relating to clamping can be mitigated at each machine.

With Pal system, the pitch error between XYZ axes positioning pallet clamp and θ Z axes positioning pallet clamp is tolerated by cut type taper cone even under thermal change conditions. Furthermore, since Z axis is positioned by 4 points of seating surface with no effect from pitch error, surface accuracy of pallet is sustained at high levels.

Pal system configuration pattern 1

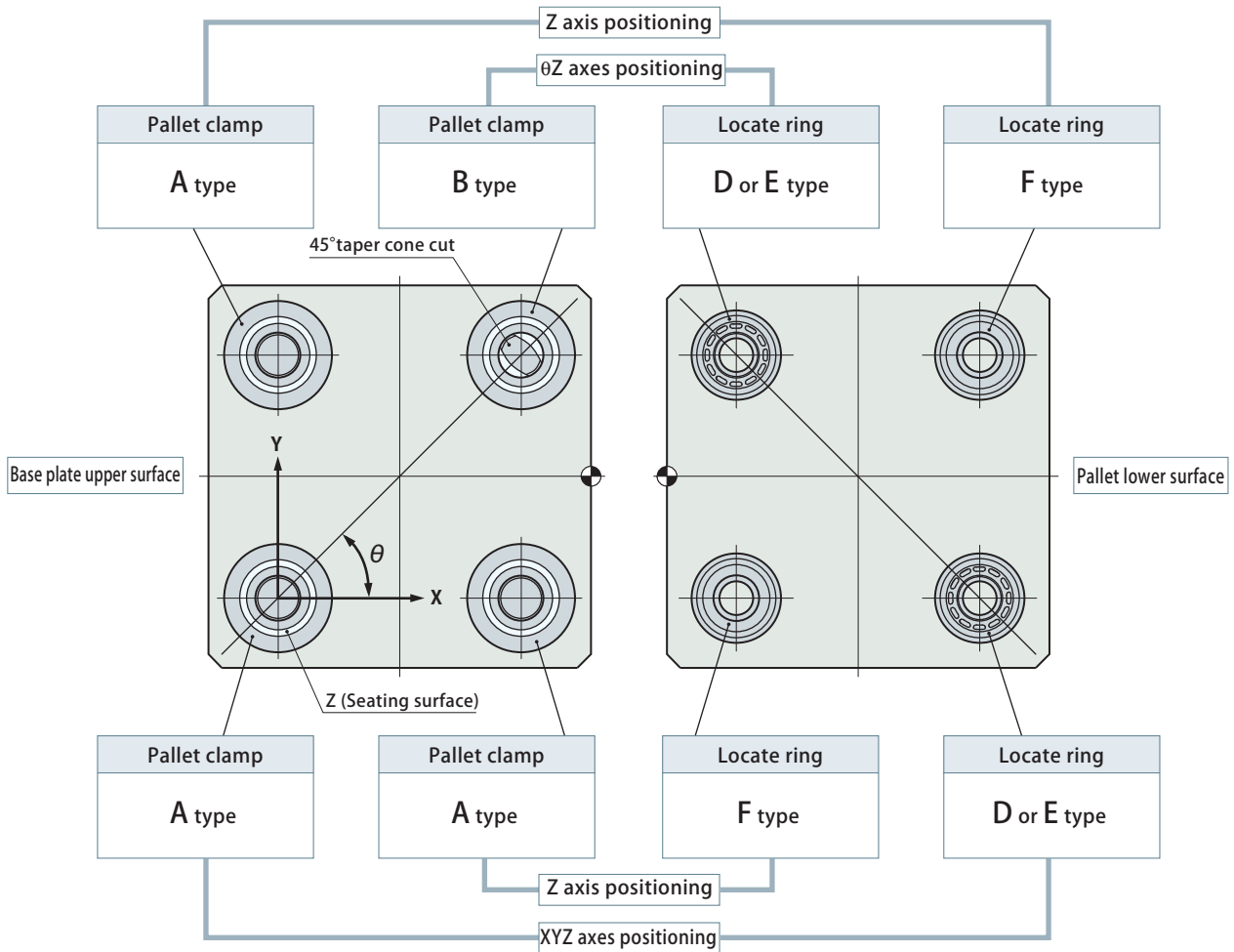

Pal system configuration pattern 2

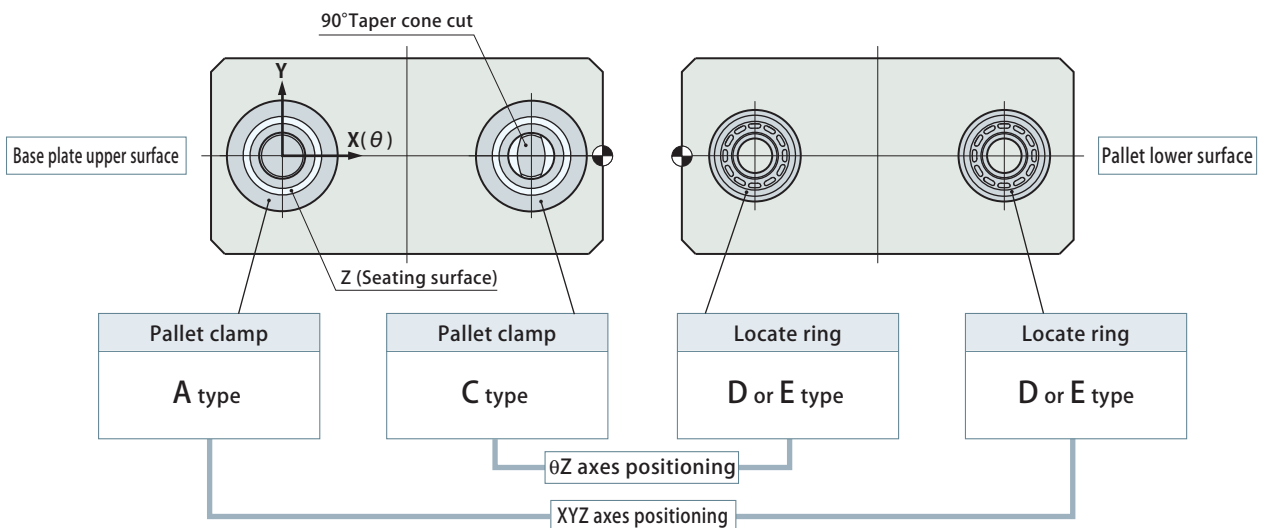

Model designation

	Type	Size	Mounting method
Spring clamp	A : A type B : B type C : C type S : Shim	03	H : Flange mounting
Hydraulic clamp		06	
Locate ring	D : D type * ¹ E : E type F : F type S : Shim P : Protective plate * ²	10	T : Upper surface mounting D : Lower surface mounting F : Flange mounting
		16	
		25	
		40	

*1 : D type of locate ring is limited to sizes of 03, 06, 10, and 16. *2: The protective plate is only flange mounting type.

Note: Be sure to specify serial numbers when placing repeat orders.

(Serial numbers and models are laser marked on clamps and locate ring bodies; For shim and protective plate, same serial numbers as clamps and locate rings may be specified.)

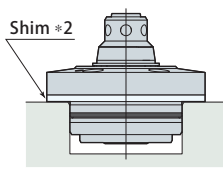
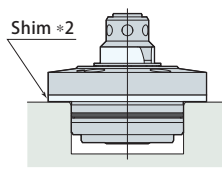
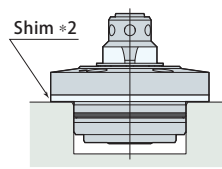
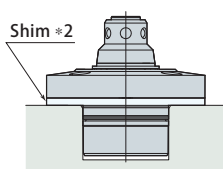
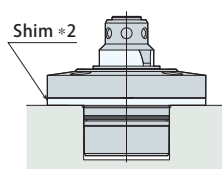
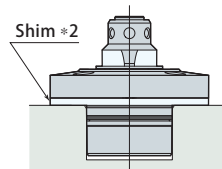
Pallet clamp List of models	A type Taper cone circle	B type * ³ 45° taper cone	C type * ³ 90° taper cone
Spring clamp Hydraulic unclamp model CPC * ¹	model CPC-A□□ 	model CPC-B□□ 	model CPC-C□□ 
Hydraulic clamp Hydraulic unclamp model CPH * ¹	model CPH-A□□ 	model CPH-B□□ 	model CPH-C□□ 

*1 : Spring clamp model CPC and hydraulic clamp model CPH cannot be used together.

*2 : Shim of pallet clamp can be used when heights of mounted clamps vary.(option)

*3 : Taper cone cut can be selected from B type or C type.

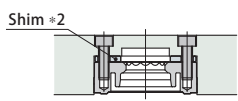
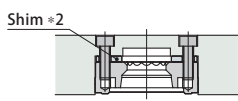
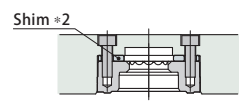
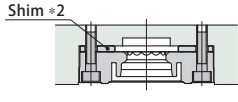
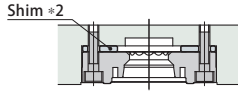
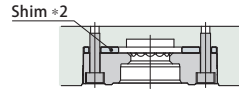
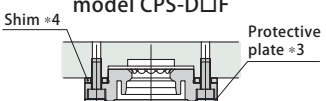
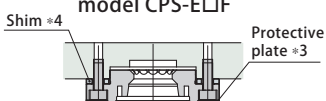
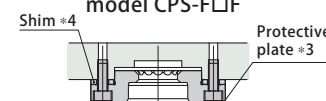
Locate ring List of models	D type * ¹ Positioning precision 10 μm	E type * ¹ Positioning precision 3 μm	F type Z axis positioning
Pallet upper surface mounting	model CPS-D□□ 	model CPS-E□□ 	model CPS-F□□ 
Pallet lower surface mounting	model CPS-D□□ 	model CPS-E□□ 	model CPS-F□□ 
Flange mounting	model CPS-D□□ 	model CPS-E□□ 	model CPS-F□□ 

*1 : D type and E type of locate ring cannot be used together.

*2 : It is recommended to use a shim (option) to adjust mounting hole depth for the locate rings for pallet upper surface mounting and lower surface mounting. Grind shim to adjust thickness.

*3 : Protective plate for locate ring of flange mounting can be used to prevent damage of seating surface, when pallet must be placed on the floor, etc.(option)

*4 : Shim of locate ring of flange mounting can be used when heights of mounted locate rings vary. (option)

Spring clamp specifications

Spring clamp model		CPC- $\frac{A}{C}$ - $\frac{B}{C}$ 03H	CPC- $\frac{A}{C}$ - $\frac{B}{C}$ 06H	CPC- $\frac{A}{C}$ - $\frac{B}{C}$ 10H	CPC- $\frac{A}{C}$ - $\frac{B}{C}$ 16H	CPC- $\frac{A}{C}$ - $\frac{B}{C}$ 25H	CPC- $\frac{A}{C}$ - $\frac{B}{C}$ 40H
Lift stroke * ²		1 mm (refer to pages → 167 and 168)					
Clamping force	(kN)	4.0	6.0	10.0	16.0	25.0	40.0
Cylinder capacity	Unclamp (cm ³)	4.5	6.1	14.1	28.7	49.6	77.9
Full stroke	(mm)	4.4	4.4	5.0	6.5	7.0	7.5
Clamp stroke	(mm)	2.4	2.4	3.0	4.0	4.5	5.0
Stroke margin	(mm)	2.0	2.0	2.0	2.5	2.5	2.5
Max. allowable eccentricity for pallet setting	(mm)	1.0	1.5	2.0	2.5	3.5	4.0
Lift force * ¹ (per clamp)	Hydraulic pressure 3.5 MPa (kN)	0.4	0.4	1.5	3.2	4.6	4.6
	Hydraulic pressure 5 MPa (kN)	1.8	2.5	5.7	9.8	15.3	20.1
	Hydraulic pressure 7 MPa (kN)	3.6	5.2	11.4	18.7	29.4	40.9
Lift force calculation (P: Unclamp hydraulic pressure MPa)		0.91×P-2.73	1.39×P-4.46	2.83×P-8.42	4.42×P-12.25	7.09×P-20.18	10.39×P-31.80
Max. allowable load (including pallet) * ³	Horizontal mounting (kN)	3.0	8.0	15.0	25.0	35.0	50.0
	Vertical mounting (kN)	0.5	1.5	2.5	4.0	5.0	7.5
Mass	(kg)	0.5	0.7	1.6	3.0	5.6	9.6

Working pressure range: 3.5 to 7 MPa Proof pressure: 10.5 MPa Operating temperature: 0 to 70°C

Fluid used: General mineral based hydraulic oil (ISO-VG32 equivalent) Recommended air blow pressure: 0.3 to 0.5 MPa

*1 : Set hydraulic pressure for movable load or more. *2 : This is the amount for lifting pallet when unclamping.

*3 : This is maximum allowable load of pallet, regardless of how many clamps are used.

Hydraulic clamp specifications

Hydraulic clamp model		CPH- $\frac{A}{C}$ - $\frac{B}{C}$ 03H	CPH- $\frac{A}{C}$ - $\frac{B}{C}$ 06H	CPH- $\frac{A}{C}$ - $\frac{B}{C}$ 10H	CPH- $\frac{A}{C}$ - $\frac{B}{C}$ 16H	CPH- $\frac{A}{C}$ - $\frac{B}{C}$ 25H	CPH- $\frac{A}{C}$ - $\frac{B}{C}$ 40H
Lift stroke * ³		1 mm (refer to pages → 169 and 170)					
Clamping force	Hydraulic pressure 0 MPa * ¹ (kN)	0.3	0.3	0.4	0.5	0.6	0.8
	Hydraulic pressure 5 MPa (kN)	2.9	4.3	7.1	11.4	17.9	28.6
	Hydraulic pressure 7 MPa (kN)	4.0	6.0	10.0	16.0	25.0	40.0
Cylinder capacity	Unclamp (cm ³)	1.7	2.8	4.8	9.9	16.0	27.2
	Clamp (cm ³)	1.3	2.1	3.8	7.8	12.6	21.4
Full stroke	(mm)	4.4	4.4	5.0	6.5	7.0	7.5
Clamp stroke	(mm)	2.4	2.4	3.0	4.0	4.5	5.0
Stroke margin	(mm)	2.0	2.0	2.0	2.5	2.5	2.5
Max. allowable eccentricity for pallet setting	(mm)	1.0	1.5	2.0	2.5	3.5	4.0
Lift force * ² (per clamp)	Hydraulic pressure 3.5 MPa (kN)	1.1	1.9	3.0	4.9	7.5	12.0
	Hydraulic pressure 5 MPa (kN)	1.7	2.9	4.4	7.2	11.0	17.5
	Hydraulic pressure 7 MPa (kN)	2.4	4.2	6.4	10.2	15.5	24.8
Lift force calculation (P: Unclamp hydraulic pressure MPa)		0.38×P-0.24	0.63×P-0.28	0.96×P-0.37	1.52×P-0.41	2.29×P-0.50	3.63×P-0.67
Max. allowable load * ⁴	Horizontal mounting (kN)	3.0	8.0	15.0	25.0	35.5	50.0
	Vertical mounting (kN)	0.5	1.5	2.5	4.0	5.0	7.5
Mass	(kg)	0.3	0.6	0.8	1.6	2.7	4.9

Working pressure range: 5 to 7 MPa(CPS-E), 2 to 7 MPa(CPS-D, CPS-F) Proof pressure: 10.5 MPa Operating temperature: 0 to 70°C

Fluid used: General mineral based hydraulic oil (ISO-VG32 equivalent) Recommended air blow pressure: 0.3 to 0.5 MPa

*1 : Clamping capacity for no hydraulic pressure shown. *2 : Set hydraulic pressure for movable load or more.

*3 : This is the amount for lifting pallet when unclamping. *4 : This is maximum allowable load of pallet, regardless of how many clamps are used.

Locate ring specifications

(kg)

Type	Locate ring (upper surface mounting)							Locate ring (lower surface mounting)							Locate ring (flange mounting)							
D type	Model	CPS-D03T	CPS-D06T	CPS-D10T	CPS-D16T			CPS-D03D	CPS-D06D	CPS-D10D	CPS-D16D			CPS-D03F	CPS-D06F	CPS-D10F	CPS-D16F					
	Positioning precision	10 μm							10 μm							10 μm						
	Mass	0.1	0.2	0.3	0.7			0.2	0.3	0.5	1.2			0.1	0.2	0.3	0.8					
E type	Model	CPS-E03T	CPS-E06T	CPS-E10T	CPS-E16T	CPS-E25T	CPS-E40T	CPS-E03D	CPS-E06D	CPS-E10D	CPS-E16D	CPS-E25D	CPS-E40D	CPS-E03F	CPS-E06F	CPS-E10F	CPS-E16F	CPS-E25F	CPS-E40F			
	Positioning precision	3 μm							3 μm							3 μm						
	Mass	0.1	0.2	0.3	0.7	1.2	2.0	0.2	0.3	0.5	1.2	2.0	3.1	0.1	0.2	0.3	0.8	1.5	2.5			
F type	Model	CPS-F03T	CPS-F06T	CPS-F10T	CPS-F16T	CPS-F25T	CPS-F40T	CPS-F03D	CPS-F06D	CPS-F10D	CPS-F16D	CPS-F25D	CPS-F40D	CPS-F03F	CPS-F06F	CPS-F10F	CPS-F16F	CPS-F25F	CPS-F40F			
	Positioning precision	Z axis positioning *							Z axis positioning *							Z axis positioning *						
	Mass	0.1	0.2	0.3	0.7	1.1	1.8	0.2	0.3	0.5	1.1	1.9	3.0	0.1	0.2	0.4	0.8	1.5	2.4			
Dimensions reference page	Refer to pages → 171 and 172							Refer to pages → 173 and 174							Refer to pages → 175 and 176							

*: F type (Z axis positioning) needs the positioning of XY axes.

Height of pallet from base plate

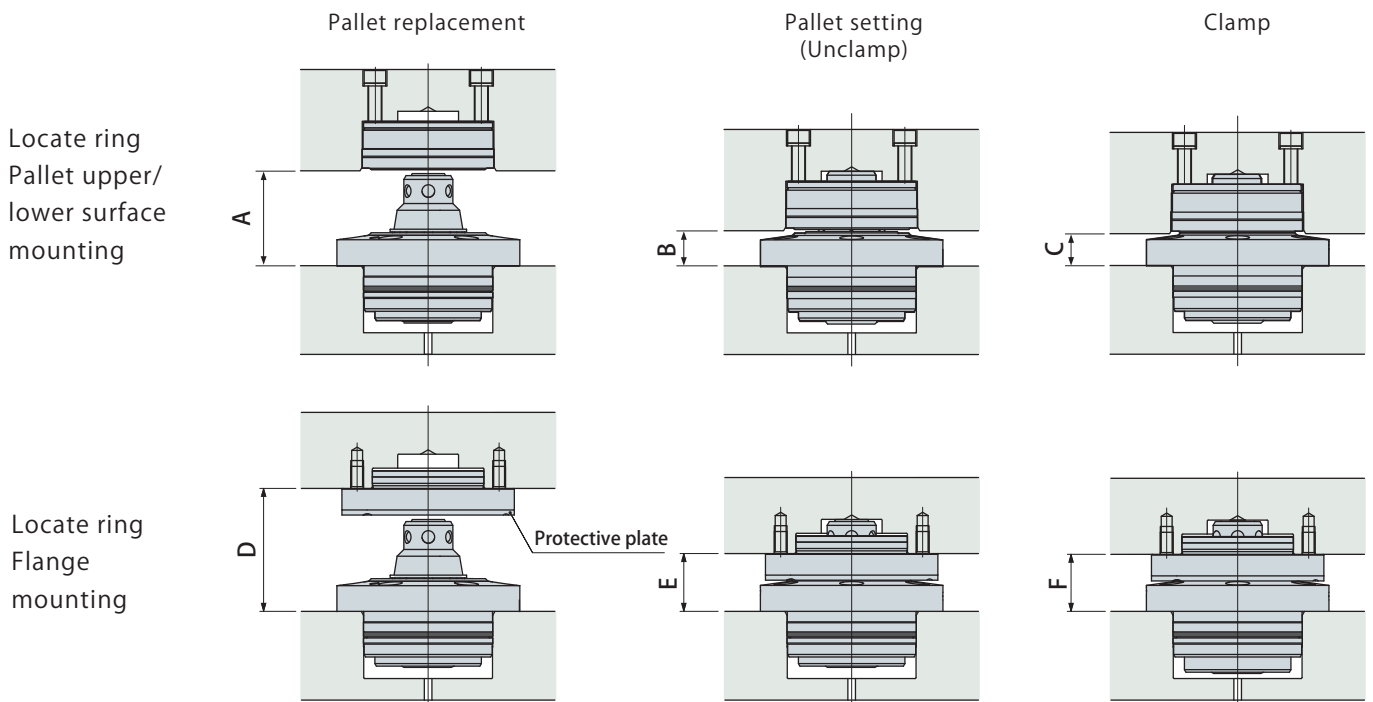

(mm)

Spring clamp Hydraulic clamp		CPC ^A CPH ^B - ^C 03H	CPC ^A CPH ^B - ^C 06H	CPC ^A CPH ^B - ^C 10H	CPC ^A CPH ^B - ^C 16H	CPC ^A CPH ^B - ^C 25H	CPC ^A CPH ^B - ^C 40H
Locate ring Pallet upper/ lower surface mounting	A	Min. 33	Min. 38	Min. 44	Min. 55	Min. 66	Min. 79
	B	12.5	13.5	15.5	18.5	22.5	28.5
	C	11.5	12.5	14.5	17.5	21.5	27.5
Locate ring Flange mounting	D	Min. 43	Min. 48	Min. 56	Min. 71	Min. 86	Min. 104
	E	22	23.5	27.5	33.5	41	52
	F	21	22.5	26.5	32.5	40	51

Note 1. Pallet lift capacity for dimension A or D or more is needed to replace pallet.

2. The height from base plate to pallet varies when using shim for pallet clamp or locate ring (mounted on flange).

Former type pallet clamps (model CPC-□□F-CPH-□□F) have different lift stroke, air blow (air blow connection port, sealing method, connecting pipe diameter), locate ring mounting dimensions. Please bear this in mind when placing repeat orders. Inquire separately regarding former type pallet clamps.

Dimensions

CPC-B03H

Spring clamp

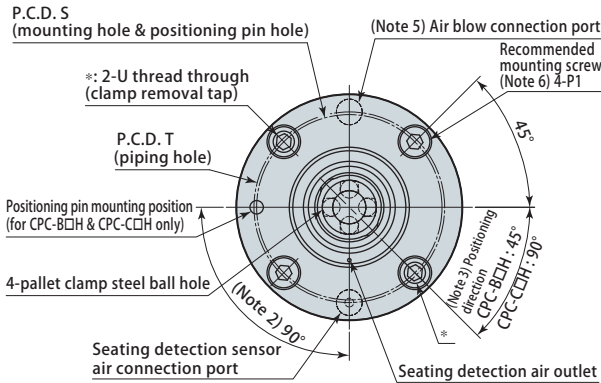

CPC-B16H

Spring clamp

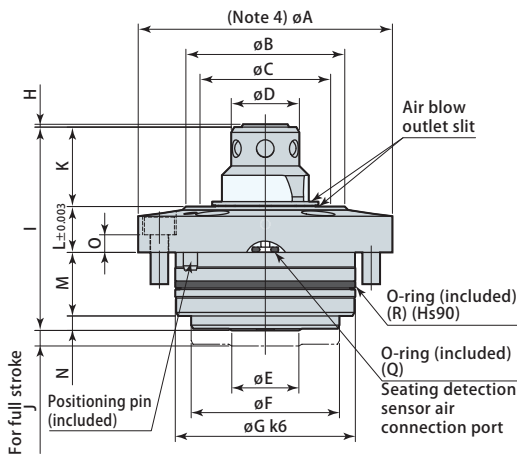
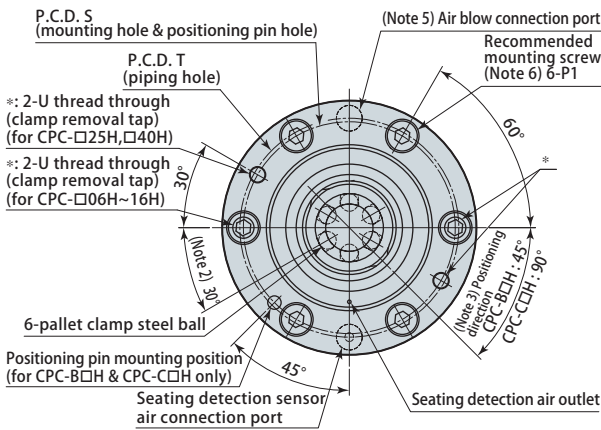

(mm)

Model	CPC-B03H	CPC-B06H	CPC-B10H	CPC-B16H	CPC-B25H	CPC-B40H
A	64	72	100	120	150	175
B	32	45	48	66	78	94
C	26	37	40	56	66	78
D	15.3	19.3	23	29.4	37.3	46
E	16	19	29	35	45	56
F	34	42	60	75	95	115
G	43 ^{+0.018} _{+0.002}	51 ^{+0.021} _{+0.002}	74 ^{+0.021} _{+0.002}	89 ^{+0.025} _{+0.003}	110 ^{+0.025} _{+0.003}	130 ^{+0.028} _{+0.003}
H	1.5	1.5	1.3	1.3	1.3	1.3
I	50.6	57.6	68	85.5	107	129.5
J	4.4	4.4	5	6.5	7	7.5
K	19	22.5	26	34	41	48
L	12	13	15	18	22	28
M	18	18	24	27	32	35
N	1.6	4.1	3	6.5	12	18.5
O	3.5	5	4	5	5	7
P1	M5×0.8 length 12	M5×0.8 length 14	M6×1 length 16	M8×1.25 length 20	M10×1.5 length 25	M12×1.75 length 30
P2	M5×0.8 length 14	M5×0.8 length 16	M6×1 length 16	M8×1.25 length 20	M10×1.5 length 25	M12×1.75 length 30
Q	P4	P4	P4	P6	P8	P10
R	AS568-029	AS568-032	AS568-147	AS568-152	AS565-155	AS568-158
S	52.5	60	86	104	130	152
T	54	62	86	104	130	152
U	M6×1	M6×1	M8×1.25	M10×1.5	M10×1.5	M12×1.75

Note 1. This diagram depicts CPC-B□H.

2. Be sure to match up phase of pallet clamp steel balls and locate ring steel ball grooves.
3. Positioning direction is the direction in which tapered surface has not been cut.
4. Use øA, which has been ground at the same time as tapered surface, for positioning measurement after mounting.
5. Air blow connection port is metal seal.
6. Mounting screws are not included.
Recommended mounting screws when using shims is P2.
7. Coupler (pages → 181 to 186) recommended when using couplers in a set.
8. Dimensions are different from former pallet clamp (model CPC-□□H).

Dimensions

(mm)

Mounting details

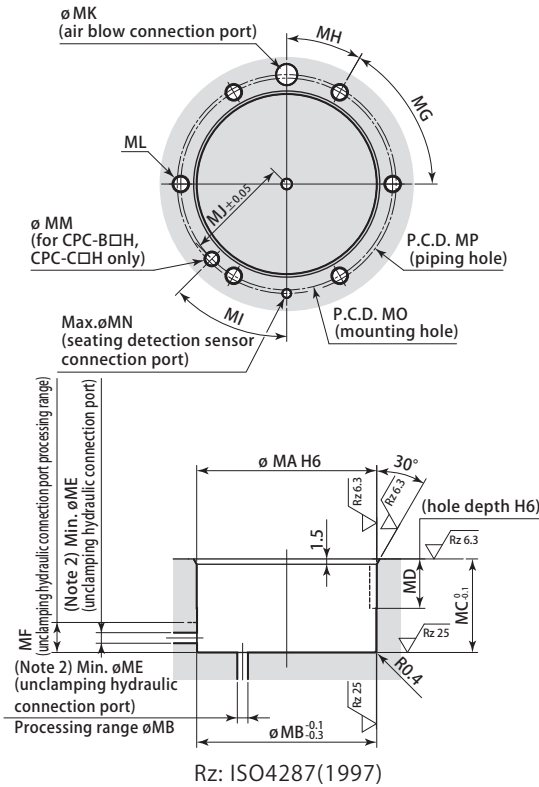

Model	CPC-B03H	CPC-B06H	CPC-B10H	CPC-B16H	CPC-B25H	CPC-B40H
MA	43 ^{+0.016} ₀	51 ^{+0.019} ₀	74 ^{+0.019} ₀	89 ^{+0.022} ₀	110 ^{+0.022} ₀	130 ^{+0.025} ₀
MB	43	51	74	89	110	130
ME	3	3	3	3	4	4
MF	6	8.5	8	13	19	26
MG	45°	60°	60°	60°	60°	60°
MH	45°	30°	30°	30°	30°	30°
MI	90°	45°	45°	45°	45°	45°
MJ	26.25	30	43	52	65	76
MK	4.5 ~ 7	4.5 ~ 7	5.5 ~ 8	6 ~ 9	7 ~ 11	7 ~ 13
MN	2.5	2.5	2.5	4	6	8
MO	52.5	60	86	104	130	152
MP	54	62	86	104	130	152

Standard specifications

MC	24	26.5	32	40	51	61
MD	14	14	15	15	16	16
ML	M5 depth 11	M5 depth 11	M6 depth 15	M8 depth 18	M10 depth 23	M12 depth 26
MM	4.1 ^{+0.1} ₀ depth 6	4.1 ^{+0.1} ₀ depth 6	4.1 ^{+0.1} ₀ depth 6	6.1 ^{+0.1} ₀ depth 6	6.1 ^{+0.1} ₀ depth 6	6.1 ^{+0.1} ₀ depth 6

Shim specifications

MC	21	23.5	29	37	47	57
MD	11	11	12	12	12	12
ML	M5 depth 10	M5 depth 10	M6 depth 12	M8 depth 15	M10 depth 19	M12 depth 22
MM	4.1 ^{+0.1} ₀ depth 4	4.1 ^{+0.1} ₀ depth 4	4.1 ^{+0.1} ₀ depth 4	6.1 ^{+0.1} ₀ depth 4	6.1 ^{+0.1} ₀ depth 4	6.1 ^{+0.1} ₀ depth 4

CPC-S03H Shim (option)

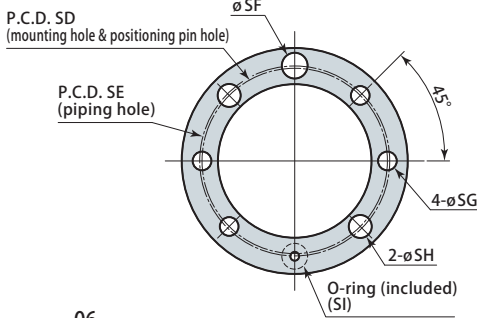

CPC-S16H Shim (option)

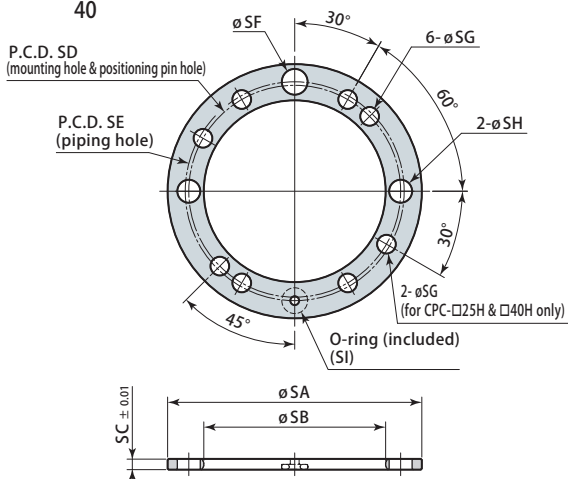

Note 1. Process with shim specification dimensions when shim is attached. Processing with standard specification dimensions will result in clamp damage during full stroke.

2. Process either bottom or side surface of unclamp connection port.
3. Recommended piping diameter for air blow connection port is ø8 or more. Having small air piping diameter does not allow full use of air blow effects.
4. Be sure to match up phase of pallet clamp steel balls and locate ring steel ball grooves.
5. Dimensions are different from former pallet clamp (model CPC-□□F).

(mm)

Model	CPC-S03H	CPC-S06H	CPC-S10H	CPC-S16H	CPC-S25H	CPC-S40H
SA	64	72	100	120	150	175
SB	43.5	51.5	75	90	111	131
SC	3.05	3.05	3.05	3.05	4.05	4.05
SD	52.5	60	86	104	130	152
SE	54	62	86	104	130	152
SF	7.3	7.3	8.2	9.2	11.2	13.2
SG	5.3	5.3	6.3	9	11	14
SH	6.5	6.5	9	11	11	14
SI	P4	P4	P4	P6	P8	P10

Note 1. This diagram indicates dimensions at shipping.

2. Adjust thickness of shim by grinding to ensure flatness of pallet.
3. Grind shim upper surface (surface without O-ring) to adjust shim.
4. Dimensions are different from former pallet clamp (model CPC-□□F).

Dimensions

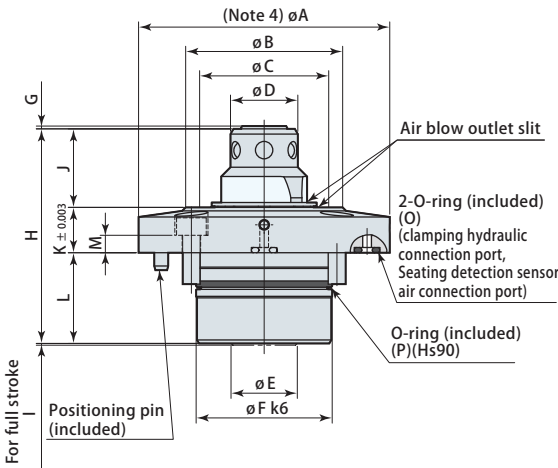
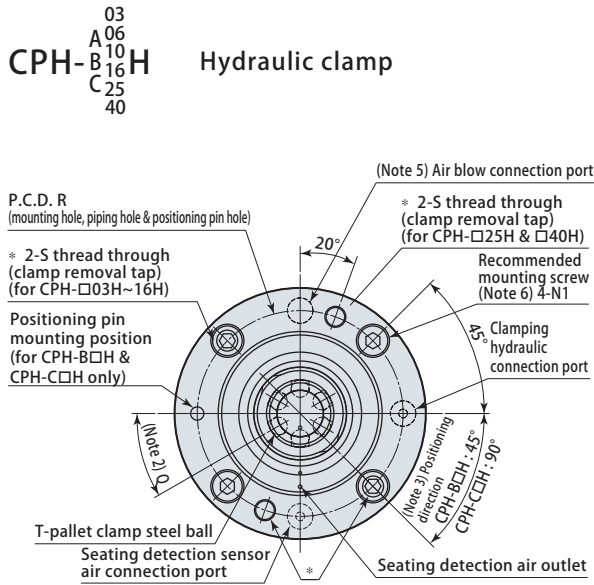

Model	CPH-B ^A □03H _C	CPH-B ^A □06H _C	CPH-B ^A □10H _C	CPH-B ^A □16H _C	CPH-B ^A □25H _C	CPH-B ^A □40H _C
A	56	72	76	100	120	145
B	32	45	48	66	78	94
C	26	37	40	56	66	78
D	15.3	19.3	23	29.4	37.3	46
E	13	19	21	28	38	48
F	28 ^{+0.015} / _{+0.002}	39 ^{+0.018} / _{+0.002}	45 ^{+0.018} / _{+0.002}	54 ^{+0.021} / _{+0.002}	65 ^{+0.021} / _{+0.002}	80 ^{+0.021} / _{+0.002}
G	1.5	1.5	1.3	1.3	1.3	1.3
H	54.5	61.5	67.5	79.5	93.5	109.5
I	0.5	0.5	0.5	0.5	0.5	0.5
J	19	22.5	26	34	41	48
K	12	13	15	18	22	28
L	23.5	26	26.5	27.5	30.5	33.5
M	3.5	5	6	6	7	9
N1	M5×0.8 length 12	M5×0.8 length 14	M6×1 length 16	M8×1.25 length 20	M10×1.5 length 25	M12×1.75 length 30
N2	M5×0.8 length 14	M5×0.8 length 16	M6×1 length 20	M8×1.25 length 25	M10×1.5 length 30	M12×1.75 length 35
O	P4	P4	P4	P6	P8	P10
P	AS568-022	AS568-028	AS568-030	AS568-135	AS565-141	AS568-150
Q	90°	30°	30°	30°	30°	30°
R	44	59	62	84	100	122
S	M6×1	M6×1	M8×1.25	M10×1.5	M10×1.5	M12×1.75
T	4	6	6	6	6	6

Note 1. This diagram depicts CPH-B□H.

- Be sure to match up phase of pallet clamp steel balls and locate ring steel ball grooves.
- Positioning direction is the direction in which tapered surface has not been cut.
- Use ϕA , which has been ground at the same time as tapered surface, for positioning measurement after mounting.
- Air blow connection port is metal seal.
- Mounting screws are not included.
Recommended mounting screws when using shims is N2.
- Coupler (pages → 181 to 186) recommended when using couplers in a set.
- Dimensions are different from former pallet clamp (model CPH-□□F).

Dimensions

Mounting details

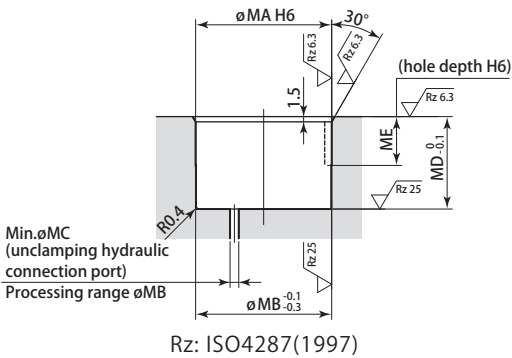
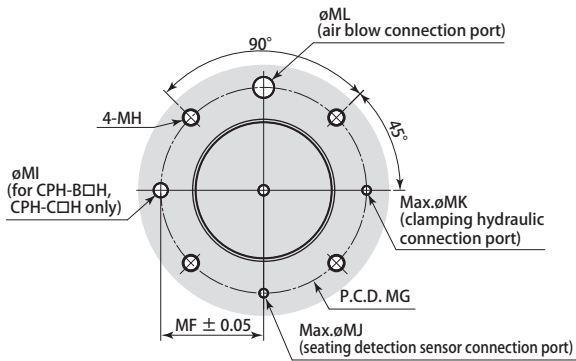

03
06
10
16
25
40

Shim (option)

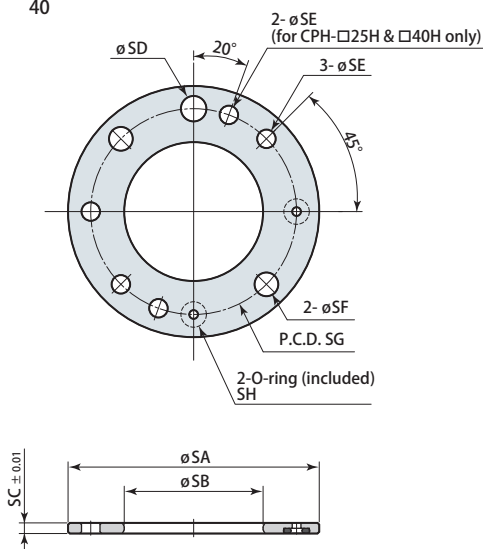

(mm)

Model	CPH- ^A _C 03H	CPH- ^A _C 06H	CPH- ^A _C 10H	CPH- ^A _C 16H	CPH- ^A _C 25H	CPH- ^A _C 40H
MA	28 ^{+0.013} ₀	39 ^{+0.013} ₀	45 ^{+0.016} ₀	54 ^{+0.019} ₀	65 ^{+0.019} ₀	80 ^{+0.019} ₀
MB	28	39	45	54	65	80
MC	3	3	3	3	4	4
MF	22	29.5	31	42	50	61
MG	44	59	62	84	100	122
MJ	2.5	2.5	2.5	4	6	8
MK	2.5	2.5	2.5	4	6	8
ML	4.5 ~ 7	4.5 ~ 7	5.5 ~ 8	6 ~ 9	7 ~ 11	7 ~ 13

Standard specifications

MD	24	26.5	27	28	31	34
ME	14	14	14	15	16	16
MH	M5 depth 11	M5 depth 11	M6 depth 15	M8 depth 17	M10 depth 21	M12 depth 24
MI	4.1 ^{+0.1} ₀ depth 6	4.1 ^{+0.1} ₀ depth 6	4.1 ^{+0.1} ₀ depth 6	6.1 ^{+0.1} ₀ depth 6	6.1 ^{+0.1} ₀ depth 6	6.1 ^{+0.1} ₀ depth 6

Shim specifications

MD	21	23.5	24	25	27	30
ME	11	11	11	12	12	12
MH	M5 depth 10	M5 depth 10	M6 depth 14	M8 depth 19	M10 depth 22	M12 depth 25
MI	4.1 ^{+0.1} ₀ depth 4	4.1 ^{+0.1} ₀ depth 4	4.1 ^{+0.1} ₀ depth 4	6.1 ^{+0.1} ₀ depth 4	6.1 ^{+0.1} ₀ depth 4	6.1 ^{+0.1} ₀ depth 4

Note 1. Process with shim specification dimensions when shim is attached. Processing with standard specification dimensions will result in clamp damage during full stroke.

2. Recommended piping diameter for air blow connection port is $\phi 8$ or more. Having small air piping diameter does not allow full use of air blow effects.
3. Be sure to match up phase of pallet clamp steel balls and locate ring steel ball grooves.
4. Dimensions are different from former pallet clamp (model CPH-□□F).

(mm)

Model	CPH-S03H	CPH-S06H	CPH-S10H	CPH-S16H	CPH-S25H	CPH-S40H
SA	56	72	76	100	120	145
SB	28.8	39.8	46	55	66	81
SC	3.05	3.05	3.05	3.05	4.05	4.05
SD	7.3	7.3	8.2	9.2	11.2	13.2
SE	5.3	5.3	6.3	9	11	14
SF	6.8	6.8	9	11	11	14
SG	44	59	62	84	100	122
SH	P4	P4	P4	P6	P8	P10

Note 1. This diagram indicates dimensions at shipping.

2. Adjust thickness of shim by grinding to ensure flatness of pallet.
3. Grind shim upper surface (surface without O-ring) to adjust shim.
4. Dimensions are different from former pallet clamp (model CPH-□□F).

Dimensions

CPS-
D03
E06
F10
F16
F25
F40

Locate ring
(upper surface mounting)

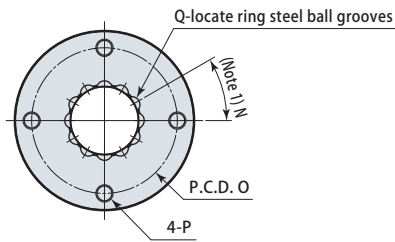

CPS-D03~16T Locate ring (D type)

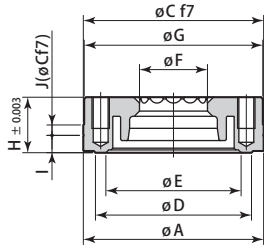

CPS-E03~40T Locate ring (E type)

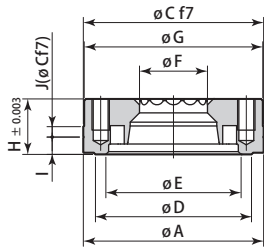

CPS-F03~40T Locate ring (F type)

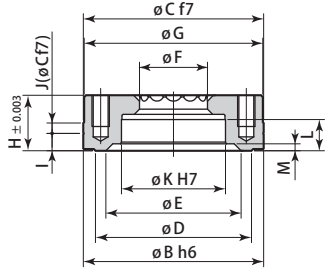

CPS-S
S03
S06
S10
S16
S25
S40

Shim (option)

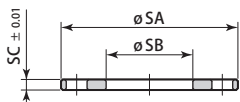
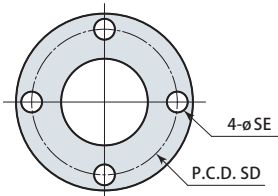

(mm)

Model	CPS- $\frac{D}{F}$ 03T	CPS- $\frac{D}{F}$ 06T	CPS- $\frac{D}{F}$ 10T	CPS- $\frac{D}{F}$ 16T	CPS- $\frac{E}{F}$ 25T	CPS- $\frac{E}{F}$ 40T
A	40 ^{+0.005} _{-0.011}	52 ^{+0.006} _{-0.013}	60 ^{+0.006} _{-0.013}	80 ^{+0.006} _{-0.013}	95 ^{+0.007} _{-0.015}	115 ^{+0.007} _{-0.015}
B	40 ⁰ _{-0.016}	52 ⁰ _{-0.019}	60 ⁰ _{-0.019}	80 ⁰ _{-0.019}	95 ⁰ _{-0.022}	115 ⁰ _{-0.022}
C	40 ^{-0.025} _{-0.050}	52 ^{-0.030} _{-0.060}	60 ^{-0.030} _{-0.060}	80 ^{-0.030} _{-0.060}	95 ^{-0.036} _{-0.071}	115 ^{-0.036} _{-0.071}
D	32	45	48	66	78	94
E	28	39	42	58	68	80
F	15.6	19.6	23.3	29.7	37.6	46.3
G	39.5	51.5	59.5	79.5	94.5	114.5
H	13	16	20	25	30	35
I	5	5	5	5	5	5
J	3	3	3	3	3	4
K	22 ^{+0.021} ₀	30 ^{+0.021} ₀	32 ^{+0.025} ₀	45 ^{+0.025} ₀	55 ^{+0.030} ₀	65 ^{+0.030} ₀
L	7	9	11	14	16	19
M	2	2.5	2.5	3	4	5
N	45°	30°	30°	30°	30°	30°
O	31	42	48	64	75	90
P	M5×0.8 depth 6	M5×0.8 depth 9	M6×1 depth 11	M8×1.25 depth 15	M10×1.5 depth 18	M12×1.75 depth 21
Q	8	12	12	12	12	12

Note 1. Be sure to match up phase of locate ring steel ball grooves and pallet clamp steel balls.

(mm)

Model	CPS-S03T	CPS-S06T	CPS-S10T	CPS-S16T	CPS-S25T	CPS-S40T
SA	39	51	59	79	94	114
SB	21	25	33	46	56	67
SC	2.05	3.05	3.05	3.05	4.05	4.05
SD	31	42	48	64	75	90
SE	6	6	7	9	11	14

Note 1. This diagram indicates dimensions at shipping.

2. Adjust thickness of shim by grinding to ensure flatness of pallet.

Dimensions

Mounting details

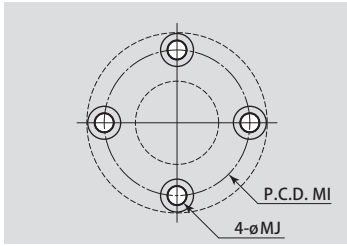

Mounting details

CPS-D03~16T, CPS-E03~40T

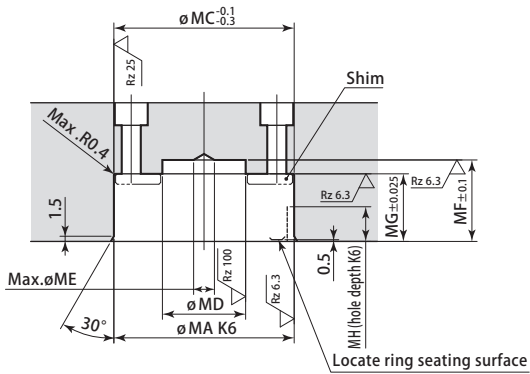

Mounting details

CPS-F03~40T

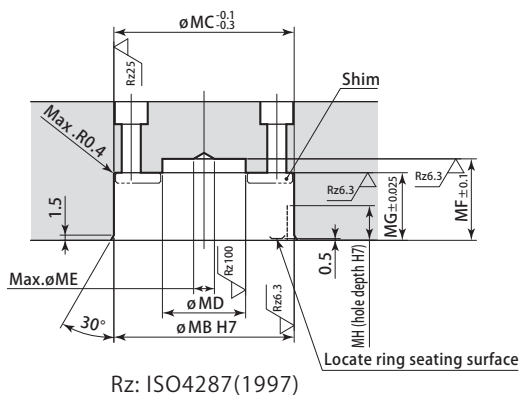

Rz: ISO4287(1997)

(mm)

Model	CPS-D _F 03T	CPS-D _F 06T	CPS-D _F 10T	CPS-D _F 16T	CPS-E _F 25T	CPS-E _F 40T
MA	40 ^{+0.003} _{-0.013}	52 ^{+0.004} _{-0.015}	60 ^{+0.004} _{-0.015}	80 ^{+0.004} _{-0.015}	95 ^{+0.004} _{-0.018}	115 ^{+0.004} _{-0.018}
MB	40 ^{+0.025} ₀	52 ^{+0.030} ₀	60 ^{+0.030} ₀	80 ^{+0.030} ₀	95 ^{+0.035} ₀	115 ^{+0.035} ₀
MC	40	52	60	80	95	115
MD	20	24	26	34	50	60
ME	6	6	8	10	12	15
MF	20	23.5	26.8	34.8	41.8	48.8
MG	15.5	19.5	23.5	28.5	34.5	39.5
MH	10	10	10	10	10	10
MI	31	42	48	64	75	90
MJ	5.5	5.5	6.6	9	11	13.5

Note 1. Be sure to match up phase of locate ring steel ball grooves and pallet clamp steel balls.

2. Dimensions are different from former pallet clamp (model CPC-□□F/CPH-□□F).

Dimensions

CPS-
D03
E06
F10
F16
F25
F40

Locate ring
(lower surface mounting)

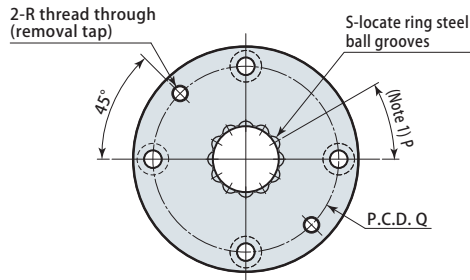

CPS-D03~16D Locate ring (D type)

Recommended mounting screw
(Note 2) 4-L

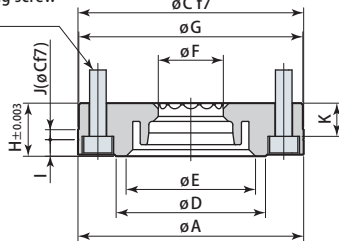

CPS-E03~40D Locate ring (E type)

Recommended mounting screw
(Note 2) 4-L

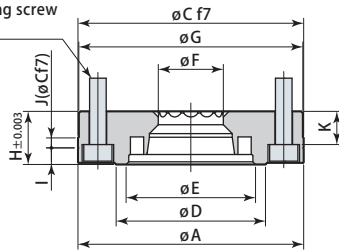

CPS-F03~40D Locate ring (F type)

Recommended mounting screw
(Note 2) 4-L

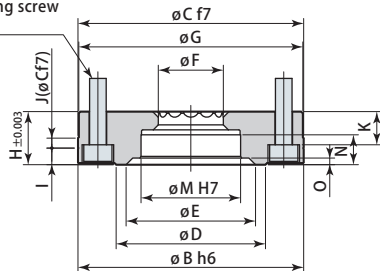

CPS-S
S03
S06
S10
S16
S25
S40

Shim (option)

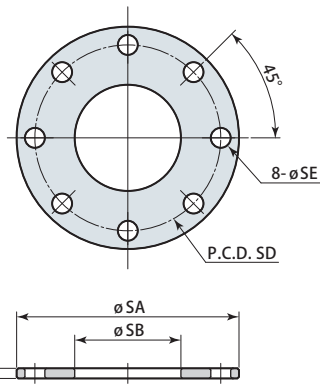

(mm)

Model	CPS- ^D _F 03D	CPS- ^D _F 06D	CPS- ^D _F 10D	CPS- ^D _F 16D	CPS- ^E _F 25D	CPS- ^E _F 40D
A	55 ^{+0.006} _{-0.013}	68 ^{+0.006} _{-0.013}	75 ^{+0.006} _{-0.013}	100 ^{+0.007} _{-0.015}	120 ^{+0.007} _{-0.015}	140 ^{+0.007} _{-0.018}
B	55 ⁰ _{-0.019}	68 ⁰ _{-0.019}	75 ⁰ _{-0.019}	100 ⁰ _{-0.022}	120 ⁰ _{-0.022}	140 ⁰ _{-0.025}
C	55 ^{-0.030} _{-0.060}	68 ^{-0.030} _{-0.060}	75 ^{-0.030} _{-0.060}	100 ^{-0.036} _{-0.071}	120 ^{-0.036} _{-0.071}	140 ^{-0.043} _{-0.083}
D	32	45	48	66	78	94
E	28	39	42	58	68	80
F	15.6	19.6	23.3	29.7	37.6	46.3
G	54.5	67.5	74.5	99.5	119.5	139.5
H	13	16	20	25	30	35
I	5	5	5	5	5	5
J	3	3	3	3	3	3
K	7	10	13	16	19	22
L	M5×0.8 length 16	M5×0.8 length 20	M6×1 length 25	M8×1.25 length 35	M10×1.5 length 40	M12×1.75 length 45
M	22 ^{+0.021} ₀	30 ^{+0.021} ₀	32 ^{+0.025} ₀	45 ^{+0.025} ₀	55 ^{+0.030} ₀	65 ^{+0.030} ₀
N	7	9	11	14	16	19
O	2	2.5	2.5	3	4	5
P	45°	30°	30°	30°	30°	30°
Q	43	56	61	82	98	116
R	M5×0.8	M5×0.8	M6×1	M8×1.25	M10×1.5	M12×1.75
S	8	12	12	12	12	12

Note 1. Be sure to match up phase of locate ring steel ball grooves and pallet clamp steel balls.

2. Mounting screws are not included.

(mm)

Model	CPS-S03D	CPS-S06D	CPS-S10D	CPS-S16D	CPS-S25D	CPS-S40D
SA	54	67	74	99	119	139
SB	24	32	39	55	65	77
SC	2.05	3.05	3.05	3.05	4.05	4.05
SD	43	56	61	82	98	116
SE	6	6	7	9	11	14

Note 1. This diagram indicates dimensions at shipping.

2. Adjust thickness of shim by grinding to ensure flatness of pallet.

Dimensions

Mounting details

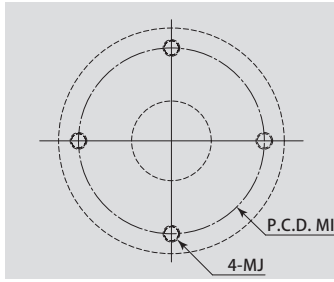

Mounting details

CPS-D03~16D, CPS-E03~40D

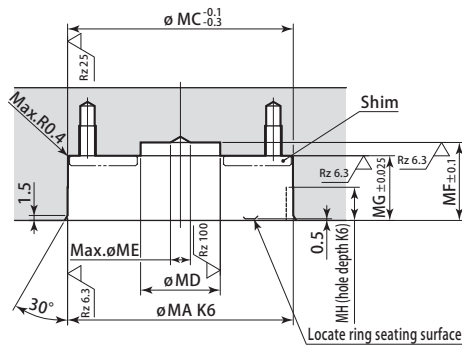

Mounting details

CPS-F03~40D

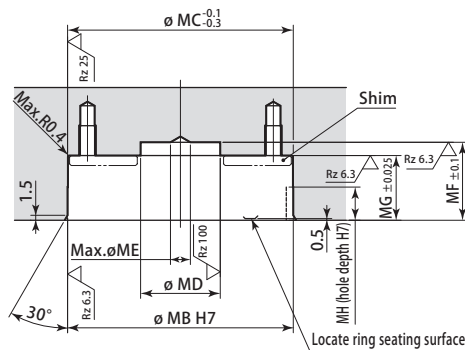

Rz: ISO4287(1997)

(mm)

Model	CPS- $\frac{D}{E}$ 03D	CPS- $\frac{D}{E}$ 06D	CPS- $\frac{D}{E}$ 10D	CPS- $\frac{D}{E}$ 16D	CPS- $\frac{E}{F}$ 25D	CPS- $\frac{E}{F}$ 40D
MA	55 $\begin{smallmatrix} +0.004 \\ -0.015 \end{smallmatrix}$	68 $\begin{smallmatrix} +0.004 \\ -0.015 \end{smallmatrix}$	75 $\begin{smallmatrix} +0.004 \\ -0.015 \end{smallmatrix}$	100 $\begin{smallmatrix} +0.004 \\ -0.018 \end{smallmatrix}$	120 $\begin{smallmatrix} +0.004 \\ -0.018 \end{smallmatrix}$	140 $\begin{smallmatrix} +0.004 \\ -0.021 \end{smallmatrix}$
MB	55 $\begin{smallmatrix} +0.030 \\ 0 \end{smallmatrix}$	68 $\begin{smallmatrix} +0.030 \\ 0 \end{smallmatrix}$	75 $\begin{smallmatrix} +0.030 \\ 0 \end{smallmatrix}$	100 $\begin{smallmatrix} +0.035 \\ 0 \end{smallmatrix}$	120 $\begin{smallmatrix} +0.035 \\ 0 \end{smallmatrix}$	140 $\begin{smallmatrix} +0.035 \\ 0 \end{smallmatrix}$
MC	55	68	75	100	120	140
MD	20	24	26	34	50	60
ME	6	6	8	10	12	15
MF	20	23.5	26.8	34.8	41.8	48.8
MG	15.5	19.5	23.5	28.5	34.5	39.5
MH	10	10	10	10	10	10
MI	43	56	61	82	98	116
MJ	M5 depth 10	M5 depth 9	M6 depth 12	M8 depth 19	M10 depth 20	M12 depth 22

Note 1. Be sure to match up phase of locate ring steel ball grooves and pallet clamp steel balls.

2. Dimensions are different from former pallet clamp (model CPC-□□F/CPH-□□F).

Dimensions

CPS-
D03
E10
F16
F25
F40

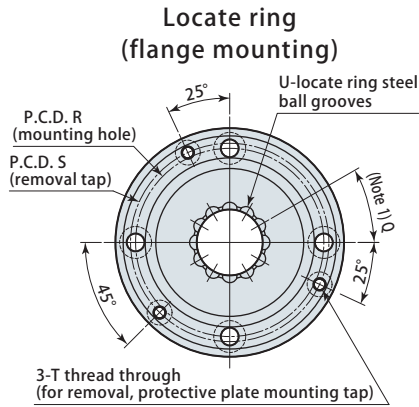

CPS-D03~16F Locate ring (D type)

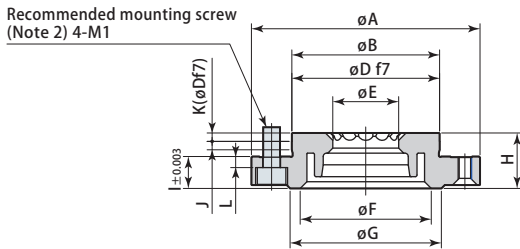

CPS-E03~40F Locate ring (E type)

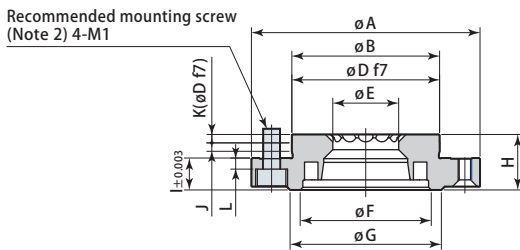

CPS-F03~40F Locate ring (F type)

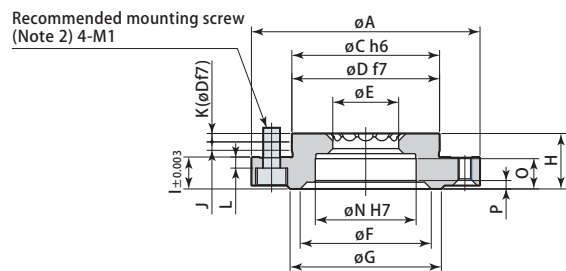

CPS-S
S03
S06
S10
S16
S25
S40

Shim (option)

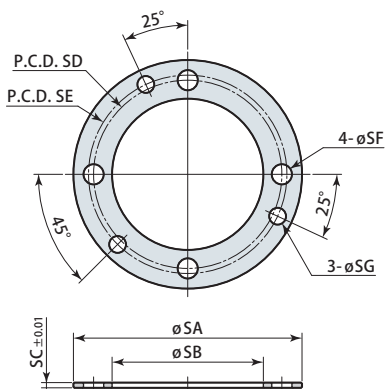

(mm)

Model	CPS-D _F 03F	CPS-D _F 06F	CPS-D _F 10F	CPS-D _F 16F	CPS-E _F 25F	CPS-E _F 40F
A	55	68	75	100	120	140
B	31 ^{+0.005} _{-0.011}	44 ^{+0.005} _{-0.011}	47 ^{+0.005} _{-0.011}	66 ^{+0.006} _{-0.013}	80 ^{+0.006} _{-0.013}	95 ^{+0.007} _{-0.015}
C	31 ⁰ _{-0.016}	44 ⁰ _{-0.016}	47 ⁰ _{-0.016}	66 ⁰ _{-0.019}	80 ⁰ _{-0.019}	95 ⁰ _{-0.022}
D	31 ^{-0.025} _{-0.050}	44 ^{-0.025} _{-0.050}	47 ^{-0.025} _{-0.050}	66 ^{-0.030} _{-0.060}	80 ^{-0.030} _{-0.060}	95 ^{-0.036} _{-0.071}
E	15.6	19.6	23.3	29.7	37.6	46.3
F	28	39	42	58	68	80
G	32	45	48	66	78	94
H	15.5	16.5	20	25	30	35
I	9	9.5	11.5	14.5	18	23
J	2.4	2.5	3.2	4.7	4.2	4.2
K	2.1	2.5	2.8	3.3	3.8	3.8
L	2.8	3.3	4.2	5.2	6.5	9.5
M1	M5×0.8 length 12	M5×0.8 length 12	M6×1 length 16	M8×1.25 length 20	M10×1.5 length 25	M12×1.75 length 30
M2	M5×0.8 length 12	M5×0.8 length 14	M6×1 length 16	M8×1.25 length 25	M10×1.5 length 25	M12×1.75 length 35
N	22 ^{+0.021} ₀	30 ^{+0.021} ₀	32 ^{+0.025} ₀	45 ^{+0.025} ₀	55 ^{+0.030} ₀	65 ^{+0.030} ₀
O	7	9	11	14	16	19
P	2	2.5	2.5	3	4	5
Q	45°	30°	30°	30°	30°	30°
R	43	56	61	82	98	116
S	46	59	64	88	106	124
T	M4×0.7	M4×0.7	M5×0.8	M5×0.8	M6×1	M6×1
U	8	12	12	12	12	12

Note 1. Be sure to match up phase of locate ring steel ball grooves and pallet clamp steel balls.

2. Mounting screws are not furnished.

3. Recommended mounting screw when using shims is M2.

(mm)

Model	CPS-S03F	CPS-S06F	CPS-S10F	CPS-S16F	CPS-S25F	CPS-S40F
SA	55	68	75	100	120	140
SB	32	45	48	67	81	96
SC	1.55	1.55	2.05	3.05	3.05	3.05
SD	43	56	61	82	98	116
SE	46	59	64	88	106	124
SF	6	6	7	9	11	14
SG	5	5	6	6	7	7

Note 1. This diagram indicates dimensions at shipping.

2. Adjust thickness of shim by grinding to ensure flatness of pallet.

Dimensions

Mounting details

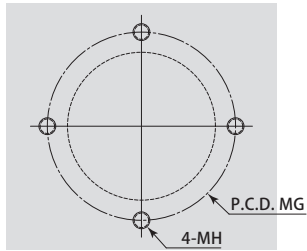

Mounting details

CPS-D03~16F, CPS-E03~40F

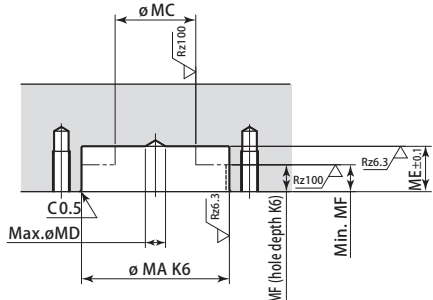

Mounting details

CPS-F03~40F

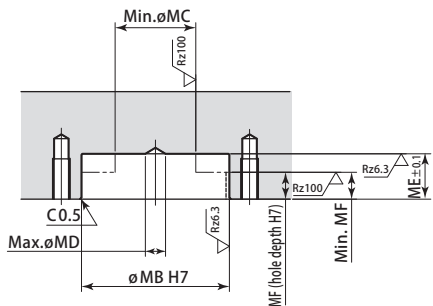

Rz: ISO4287(1997)

CPS-P⁰³₀₆¹⁰₁₆²⁵₄₀ F Protective plate (option)

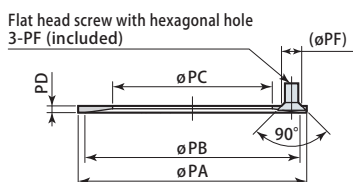
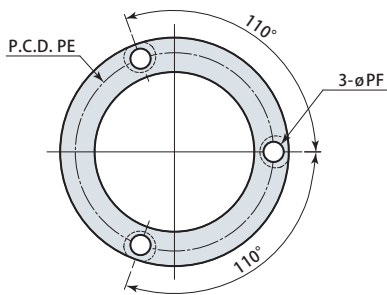

(mm)

Model	CPS-D _F 03F	CPS-D _F 06F	CPS-D _F 10F	CPS-D _F 16F	CPS-E _F 25F	CPS-E _F 40F
MA	31 ^{+0.003} _{-0.013}	44 ^{+0.003} _{-0.013}	47 ^{+0.003} _{-0.013}	66 ^{+0.004} _{-0.015}	80 ^{+0.004} _{-0.015}	95 ^{+0.004} _{-0.018}
MB	31 ^{+0.025} ₀	44 ^{+0.025} ₀	47 ^{+0.025} ₀	66 ^{+0.030} ₀	80 ^{+0.030} ₀	95 ^{+0.035} ₀
MC	20	20	26	34	50	60
MD	6	6	8	10	12	15
MG	43	56	61	82	98	116

Standard specifications

ME	10.5	13.5	14.8	19.8	23.3	25.3
MF	7.5	8	9.5	11.5	13	13
MH	M5 depth 12	M5 depth 11	M6 depth 15	M8 depth 18	M10 depth 22	M12 depth 24

Shim specifications

ME	9	12	12.8	16.8	20.3	22.3
MF	6.5	6.5	7.5	8.5	10	10
MH	M5 depth 10	M5 depth 12	M6 depth 13	M8 depth 20	M10 depth 19	M12 depth 26

Note 1. Be sure to match up phase of locate ring steel ball grooves and pallet clamp steel balls.

2. Dimensions are different from former pallet clamp (model CPC-□□F/CPH-□□F).

(mm)

Model	CPS-P03F	CPS-P06F	CPS-P10F	CPS-P16F	CPS-P25F	CPS-P40F
PA	55	68	75	100	120	140
PB	51	64	68	94	114	132
PC	34.5	47.5	50.5	68.5	80.5	96.5
PD	2	2	2	2.5	3	3
PE	46	59	64	88	106	124
PF	6	6	8	8	9	9

Pitch tolerance of Pal system

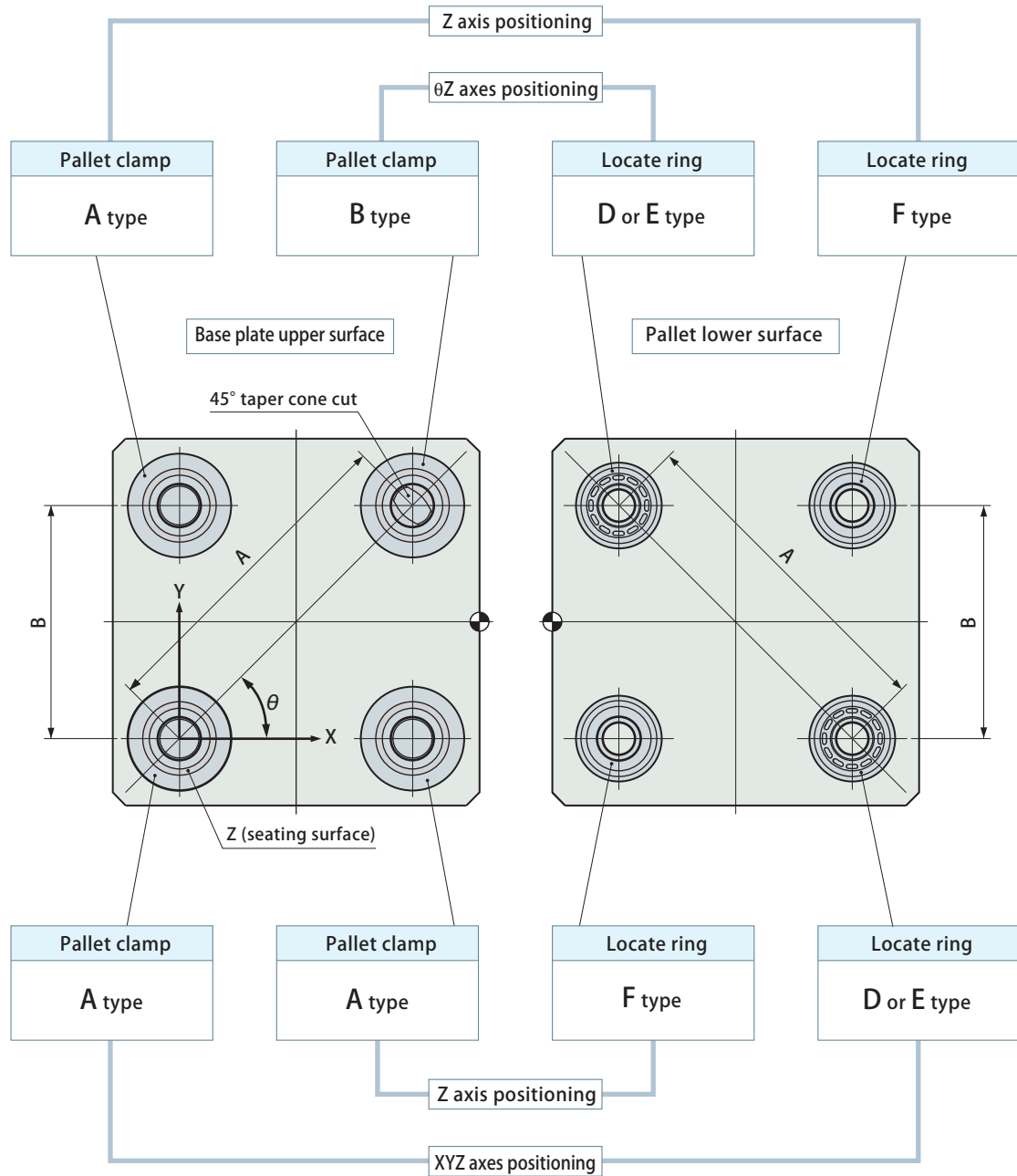

Model (size)	03	06	10	16	25	40
Pitch tolerance of A dimensions		±0.01		±0.02		±0.03
Pitch tolerance of B dimensions		±0.03		±0.04		±0.05

Method for positioning pallet changer setup table (reference)

Internal hole of F type locate ring can be used for positioning of setup table for pallet replacement with pallet changer. In order to sustain accuracy, do not allow surfaces other than those of pallet clamp CPC or CPH to come into contact with tapered surface or seating surface.

Locate ring XYZ axes and θZ axes positioning

Locate ring Z axis positioning

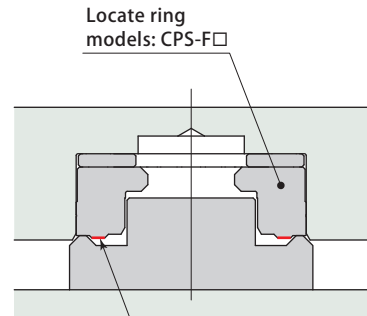
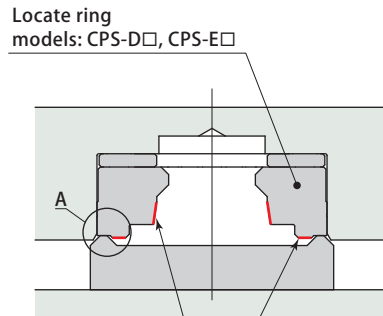
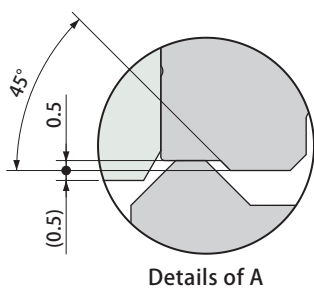

Tapered surface and seating surface must not come into contact.

Do not allow contact with seating surface.

⚠ Caution in use

For vertical mounting of pallet

- A guide pin must be installed when mounting pallet vertically.
- Ensure spacing is set in order to ensure that mounted guide pin does not affect positioning.

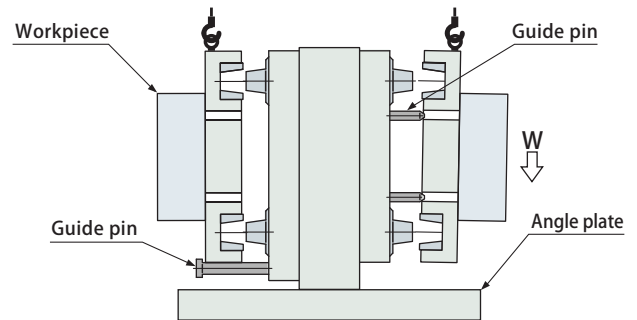

Pallet change by overhead crane

- Ensure that pallet does not lean to the side when removing pallet (allowable inclination is 2°). When dismantling pallet in particular, pulling while in a tilted condition can damage pallet clamp and locate ring. A guide pin must be installed for pallets or angle plate that has an eccentric center of gravity in order to ensure they can be removed horizontally.

