

Cam drive

Auto tool changer

Highly-durable ball gear cam drive A.T.C.

model **MTC**



Pascal
corporation

www.pascaleng.co.jp

Pamphlet PA-224E REV.0 2007.09

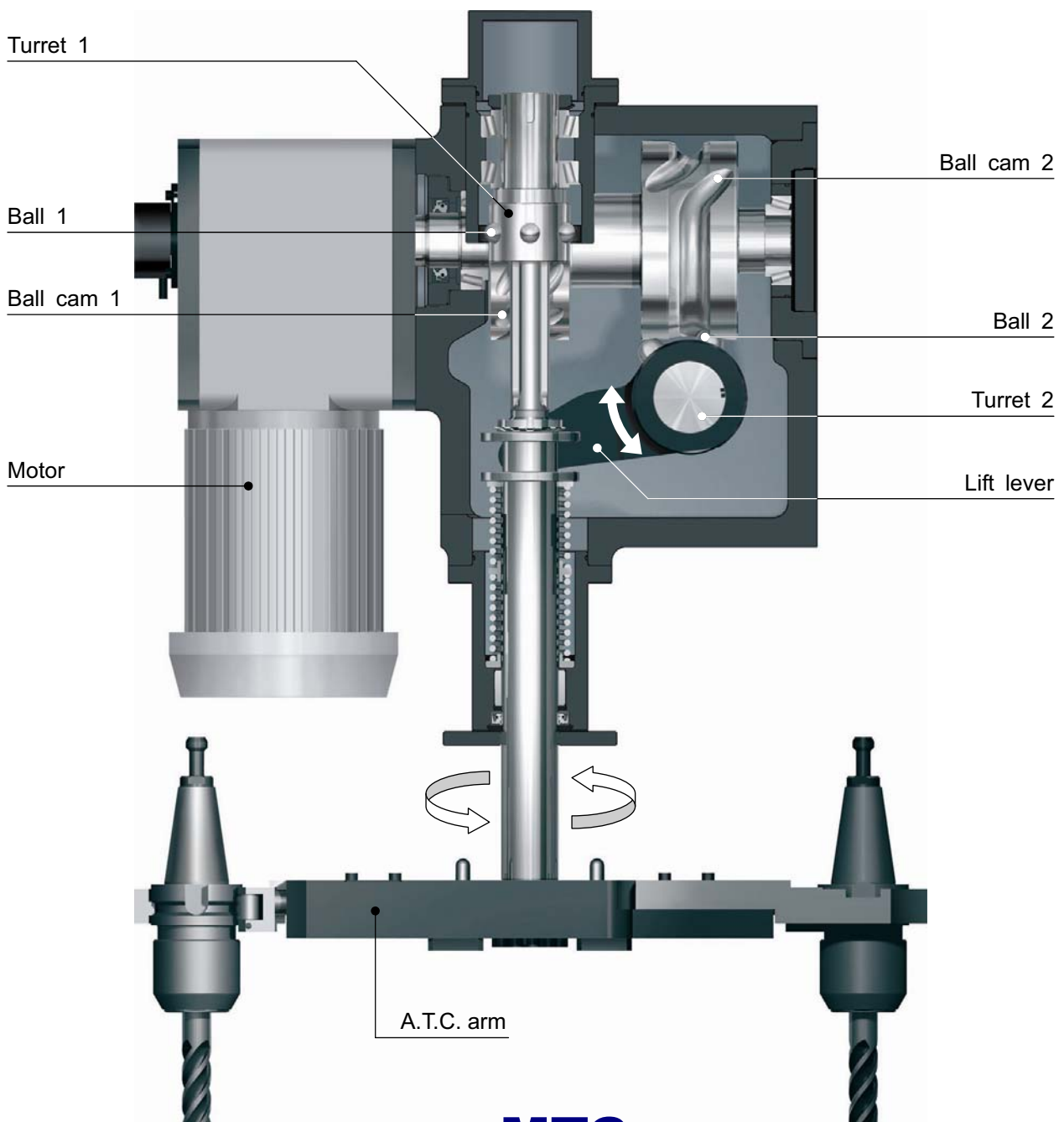
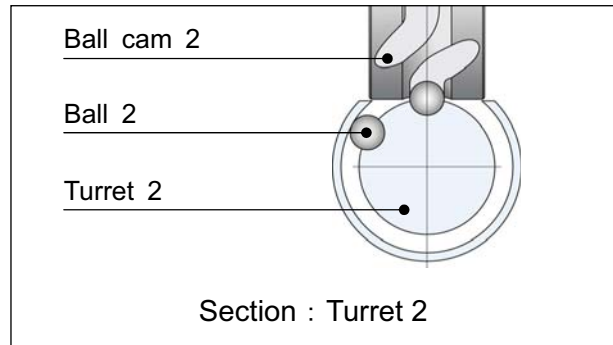
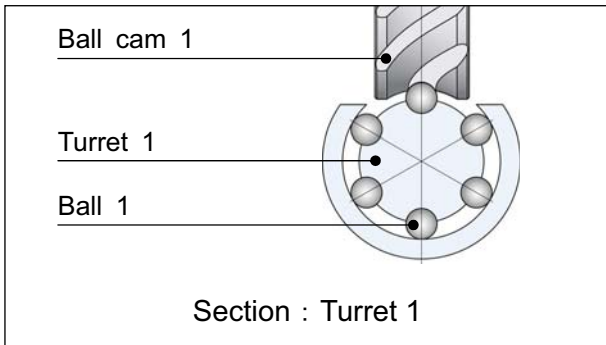

model **MTC**



Itami, Hyogo, Japan 664-8502

TEL. (072) 777-3333 FAX. (072) 777-3520



CERTIFICATE OF APPROVAL ISO9001