

## ⚠ Caution In Use

### Store/Carry

- The gas spring should not be kept in a place where they are subjected to direct sunlight, high temperatures, and high humidity. The place should not be dusty.
- Carry and keep the gas spring in a way that it does not hit other gas spring. The scratch or dent made on piston rod surface may deteriorate the product's durability.

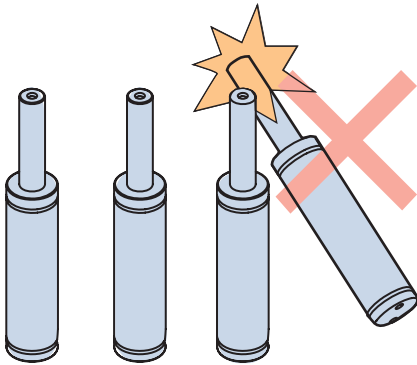

### Operation/Mounting

- Do not disassemble or modify the gas spring and piping system components. High-pressure gas is sealed inside and the parts may shoot out dangerously.
- The gas spring should not be additionally machined for any reason.
- Do not weld or cut the gas spring. Do not throw gas springs into the fire.
- Do not use the gas springs in the high-temperature environment. The maximum operational temperature is 70°C. If the operational temperature is beyond room temperature (20°C), decrease the charging pressure until it equals to the max. charging pressure (at 20°C). For the details, refer to Instruction Manual.
- Be sure to set the actual stroke within set stroke "S" range. (Actual stroke  $S_a$  :  $S_a \leq S$ ). If the piston rod over strokes, the piston rod end hits the cylinder bottom to cause deformation of the cylinder and the piston rod itself, and may cause the gas leakage.
- Avoid eccentric load to the piston rod (Acceptable eccentric angle is 0.5° or below). Eccentric loads significantly shorten the service-life of the gas spring. Pay special attention if the gas spring is mounted in a non-vertical position. The piston rod tends to lean because of its own weight.

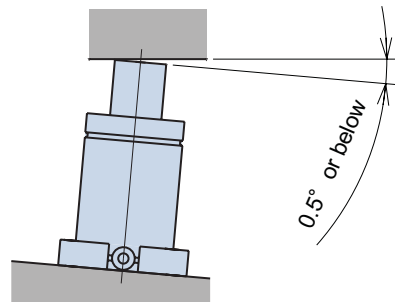

- The piston rod top should be loaded to its full surface equally. If not, adjust the cushion pin and contacting plate.

## ⚠ Caution In Use

### Safe Operation

- Never attempt to use the gas spring in a way that the piston rod is released freely and sharply. It may damage the gas spring dangerously. Especially a use as a driving force for a knock-out system must be avoided.
- The gas spring must not be fixed by the threaded hole at the top of the piston rod.
- Never attempt to lift the whole die assembly by using the threaded hole at the top of the piston rod. It should only be used to carry and mount/dismount a single gas spring.
- Do not attempt the grinding and welding operation in the vicinity of the gas spring. If it is inevitable, cover the gas spring to protect them from adherence of chips and spatter. The foreign body adherence and a scratch on the piston rod may cause a gas leakage.

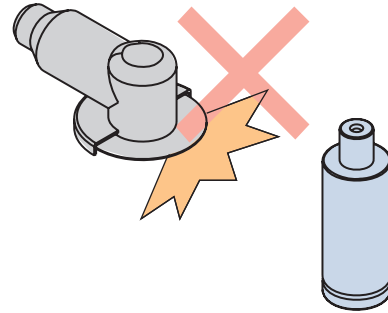
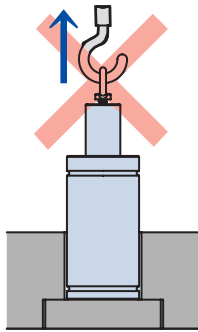

- The gas spring should be mounted securely by using threaded holes at the cylinder bottom or a flange.
- Mount the gas spring to die lubricant free area. If the oil wet gas spring makes strokes, the oil may become the oil film and intrude inside the cylinder. The accumulated drawing oil may cause of abnormally high inner pressure to damage the gas spring. Especially the chlorine and soluble oils must be avoided as they will deteriorate sealing capability of packing and shorter the gas spring life.

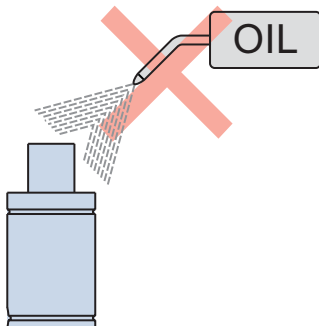

## Gas Charge/Discharge

- Do not charge/discharge gas while the gas spring is under load.
- Charge Nitrogen (N<sub>2</sub>) gas only. Never charge flammable, explosive gas and volatile liquid as they may cause an explosion accident.
- Exhaust the N<sub>2</sub> gas completely before disposal.
- Those gas springs for use outside Japan (specified as -OS) are shipped without gas charging. The user needs to charge gas before use. After charging gas, the charging gas pressure should be recorded on the pressure indication label of each gas spring by a permanent marker.



- The charging pressure should be below the designated pressure in the marking. Take adequate time to increase the gas pressure by referring the instruction manual. Gas charging range : 3.4MPa~15MPa (at 20°C).

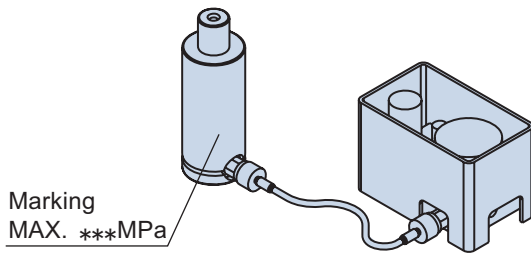

- Gas charging should be done with the piston rod fully out. If piston rod retracted in the cylinder, start charging as lower pressure as possible (0.5 MPa or lower) then increase the pressure gradually till the piston rod extended out, in order to avoid personal injury and damages of facility and equipments.

