

model **DNF**

Compact model

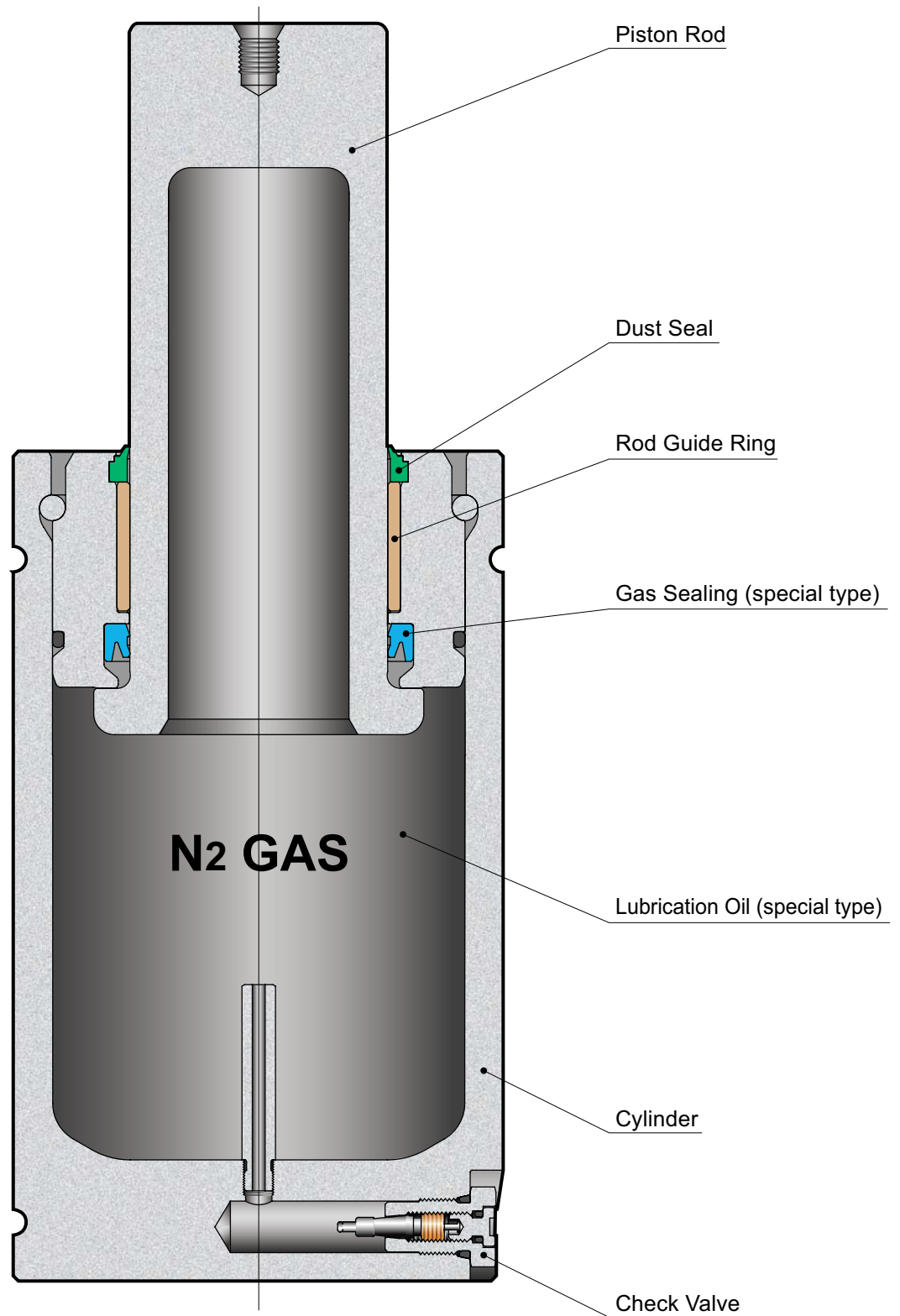

Ordering gas spring and flange by the set

Example : DNF2000-50FC-T

In case requiring a gas spring and a flange by the set, please specify the set model name as below.

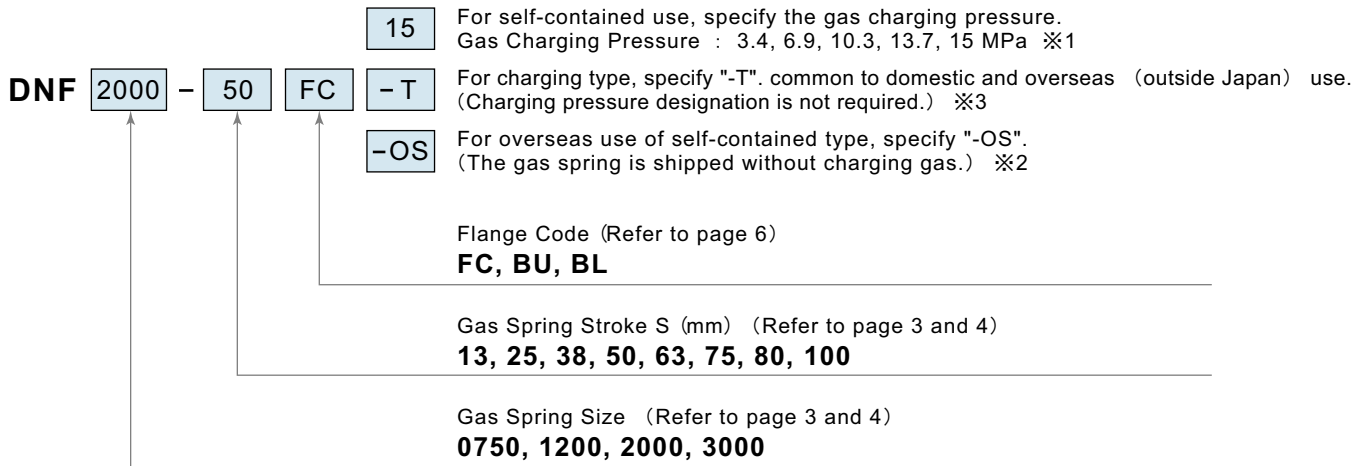

- ※1 : Choose one of the recommended gas pressure levels shown above. For the charging pressure other than above, specify the pressure to one digit after the decimal. The gas charging range is 3.4 MPa to 15 MPa at 20°C.
- ※2 : Charging gas to those gas springs to be shipped to outside Japan is prohibited by law.
- ※3 : Check valve is not mounted at shipment.

Ordering gas spring by itself

Example : DNF2000-50BF15

In case requiring only the gas spring, please specify BF as a gas spring code.

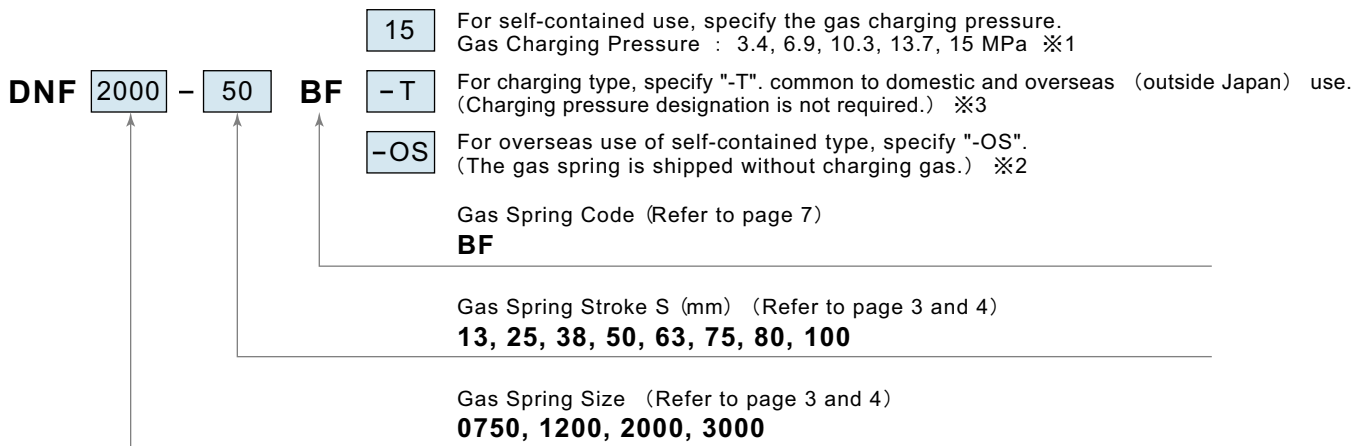

- ※1 : Choose one of the recommended gas pressure levels shown above. For the charging pressure other than above, specify the pressure to one digit after the decimal. The gas charging range is 3.4 MPa to 15 MPa at 20°C.
- ※2 : Charging gas to those gas springs to be shipped to outside Japan is prohibited by law.
- ※3 : Check valve is not mounted at shipment.

Ordering flange by itself

Example : DJF075-FC

In case requiring only the flange, please specify the model name of the flange as below.

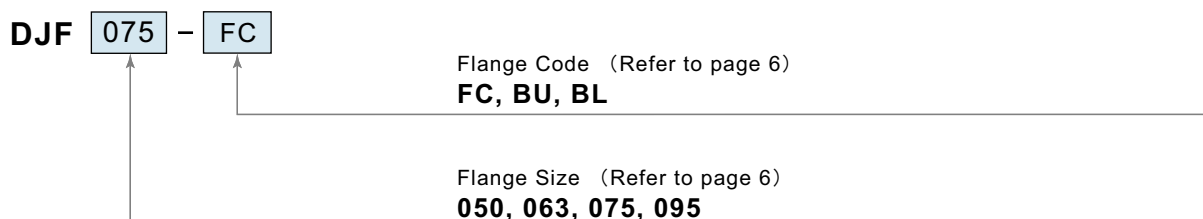

Specifications / Dimensions

Model	Stroke S mm	※1 ※2 Initial Force kN	※1 Full stroke Load kN	Compre- ssion Ratio	Mass kg	L mm	H mm	
DNF0750 -	13	13	7.40	10.6	1.44	0.9	91	78
	25	25	7.40	10.9	1.48	1.0	115	90
	38	38	7.40	11.0	1.49	1.1	141	103
	50	50	7.40	11.5	1.56	1.2	165	115
	63	63	7.40	11.4	1.55	1.3	191	128
	75	75	7.40	11.4	1.55	1.4	215	140
	80	80	7.40	11.4	1.55	1.5	225	145
	100	100	7.40	11.4	1.54	1.6	265	165
DNF1200 -	13	13	12.1	16.9	1.40	1.6	96	83
	25	25	12.1	17.6	1.46	1.7	120	95
	38	38	12.1	17.9	1.48	1.9	146	108
	50	50	12.1	18.7	1.55	2.0	170	120
	63	63	12.1	18.6	1.55	2.2	196	133
	75	75	12.1	18.6	1.54	2.4	220	145
	80	80	12.1	18.6	1.54	2.4	230	150
	100	100	12.1	18.6	1.54	2.7	270	170
DNF2000 -	13	13	18.8	25.6	1.36	2.4	106	93
	25	25	18.8	28.0	1.49	2.6	130	105
	38	38	18.8	28.2	1.50	2.8	156	118
	50	50	18.8	29.1	1.55	3.0	180	130
	63	63	18.8	29.0	1.54	3.2	206	143
	75	75	18.8	29.0	1.54	3.4	230	155
	80	80	18.8	28.9	1.53	3.5	240	160
	100	100	18.8	28.9	1.53	3.8	280	180
DNF3000 -	13	13	29.5	40.3	1.37	4.2	110	97
	25	25	29.5	44.3	1.50	4.5	134	109
	38	38	29.5	44.1	1.50	4.8	160	122
	50	50	29.5	45.7	1.55	5.1	184	134
	63	63	29.5	45.3	1.54	5.4	210	147
	75	75	29.5	45.0	1.53	5.7	234	159
	80	80	29.5	45.0	1.53	5.8	244	164
	100	100	29.5	44.7	1.52	6.3	284	184

Common dimensions
for all strokes
mm

Cylinder Base

K = 25
D = 50
P = M8 depth 8
J = 2
Z = 15.5

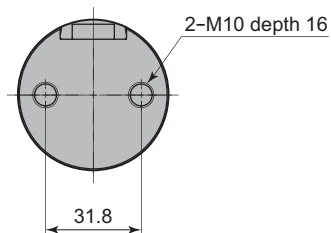

K = 32
D = 63
P = M8 depth 8
J = 2
Z = 19

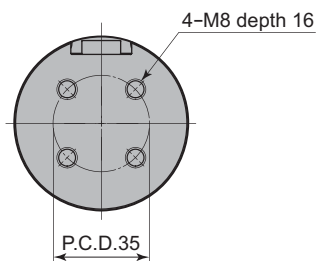

K = 40
D = 75
P = M8 depth 8
J = 2.5
Z = 21

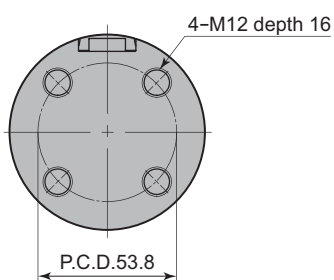

K = 50
D = 95
P = M8 depth 8
J = 2.5
Z = 24

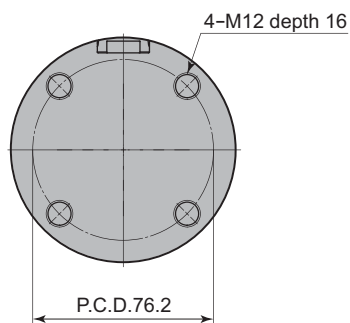

※1: Figures at initial charging pressure 15MPa (20°C).

※2: In case the initial load of 50kN level is required, please choose model DNB5000.

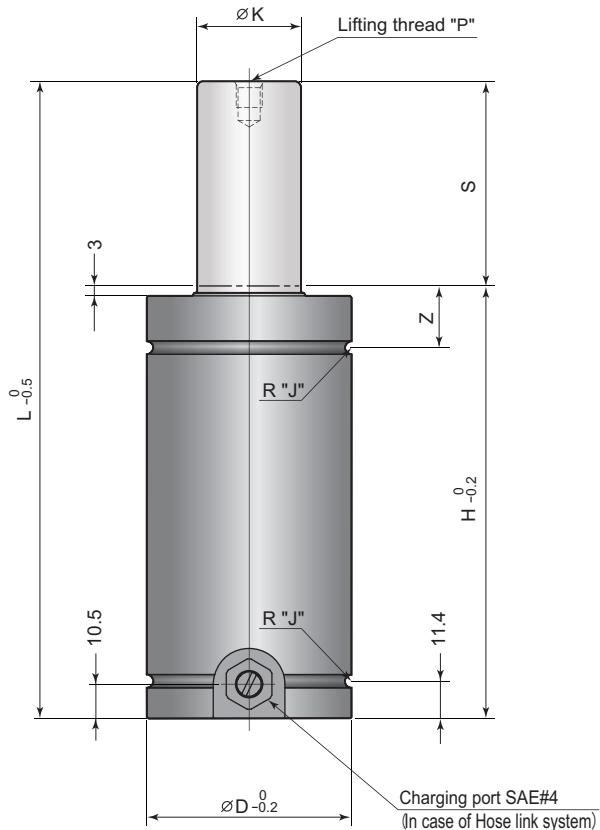

Outline drawing for 2D/3D CAD can be downloaded from our URL <http://www.pascaleng.co.jp>

⚠ Caution at stroke selection

In case of a gas spring with 38 mm or longer stroke, the actual stroke "Sa" should be within the range of "S-25 ≤ Sa ≤ S" to maintain the effect of lubricant.

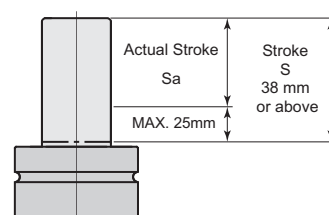

※ The performance of lubricant may differ depending on working environment.

DNF0750

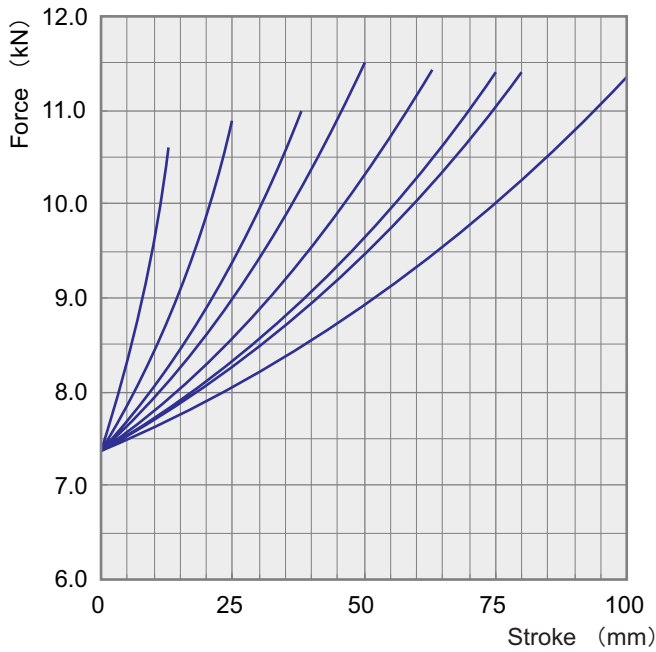

DNF1200

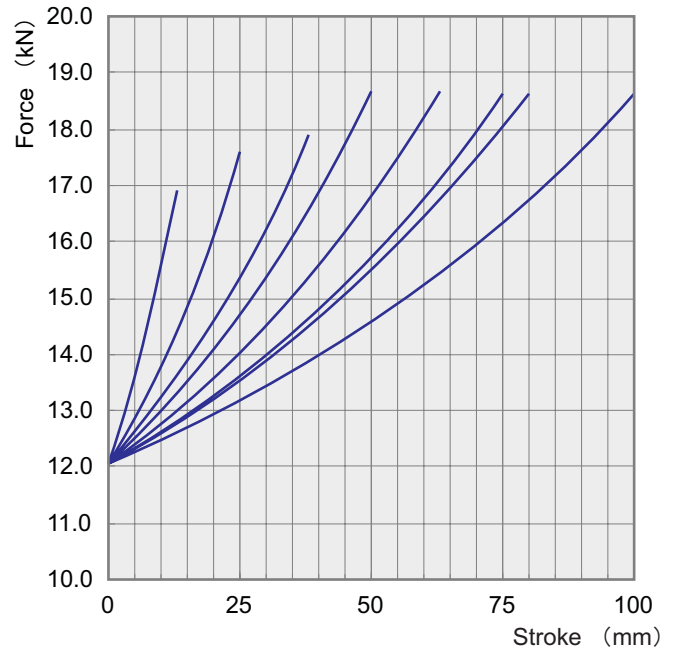

DNF2000

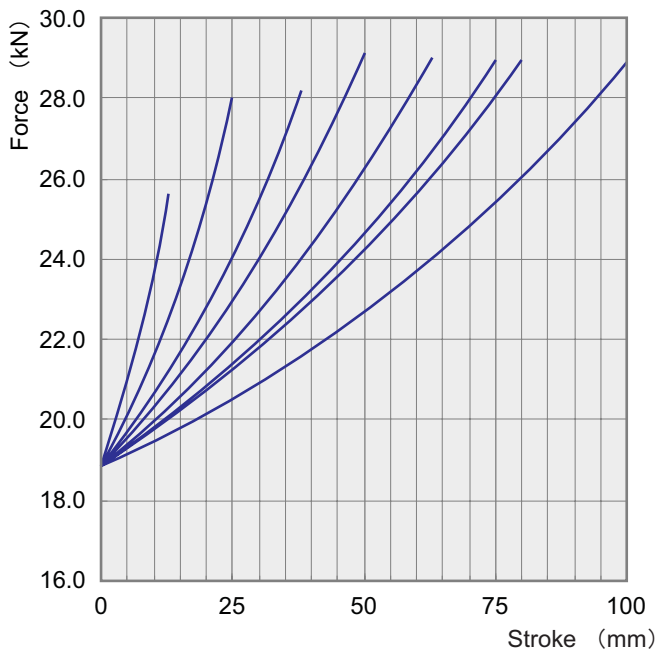

DNF3000

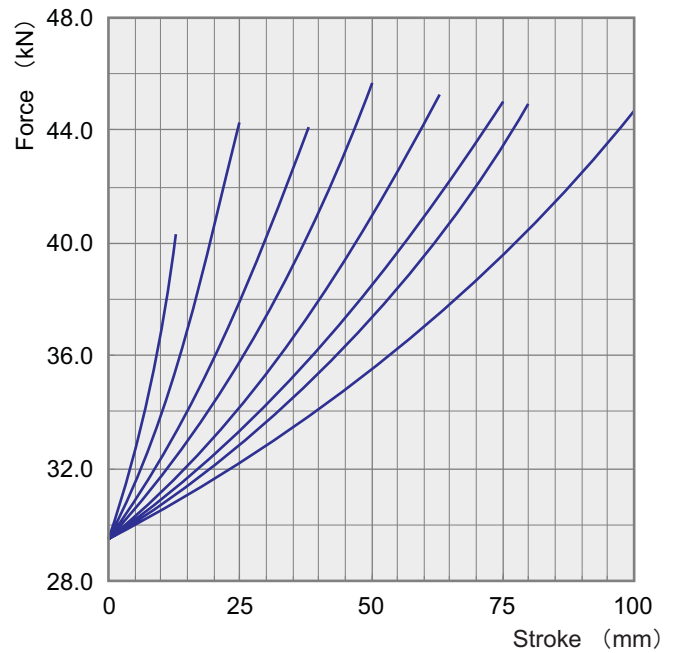

Force Variation of Different Charging Pressure

Above drawings are showing cushion forces F0 by applying the maximum charging pressure of 15MPa. When applying a charging pressure less than 15MPa, use following formula to adjust the cushion force F1. (Min. charging pressure : 3.4MPa)

$$F_1 = F_0 \times \frac{\text{Charging pressure (MPa)}}{15}$$