

Note : Flanges are designed with sufficient strength to accommodate the loading.
(The flange should support the load by its full mounting face, and should be mounted by 4 screws.)

Gas spring model	Flange model	A mm	B mm	C mm	H mm	J mm	M mm	Mass kg
DSB32	DJF032-FS	45	35	49.5	17	9	6.8	0.10
DSB38	DJF038-FS	52	40	56.5	17	9	6.8	0.12
DSB50	DJF050-FS	70	56.5	80	24	13	9	0.30

Flange mounting screws are not furnished.

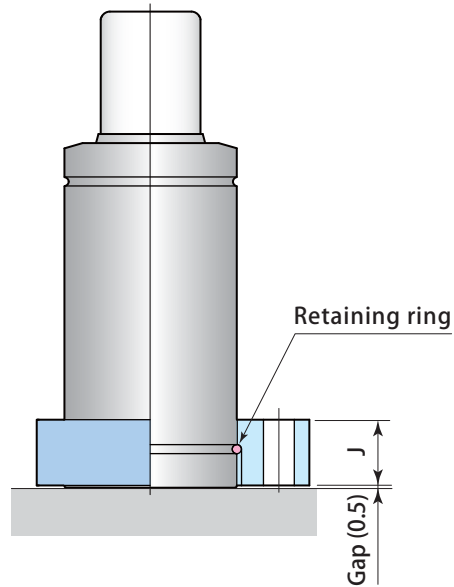
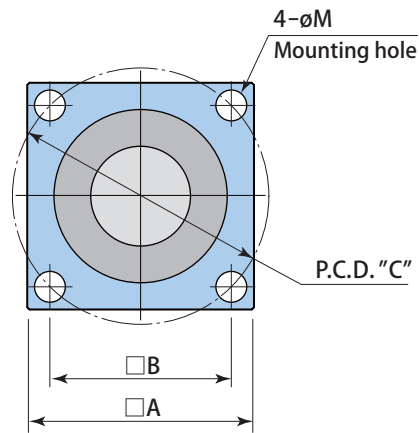

Note : The cylinder should be backed up fully at the bottom face.

Gas spring model	Flange model	A mm	B mm	C mm	J mm	M mm	Mass kg
DSB32	DJF032-BM	45	35	49.5	15	6.8	0.12
DSB38	DJF038-BM	50	40	56.5	15	6.8	0.13
DSB50	DJF050-BM	70	56.5	80	20	9	0.39

Flange mounting screws are not furnished.