



PASCAL[®] MOLD-CHANGE SYSTEM *FOR MOLDING MACHINE*

CE

Pascal
corporation

www.pascaleng.co.jp

Application AP-002E REV.5 2011.03

PASCAL MOLD-CHANGE SYSTEM

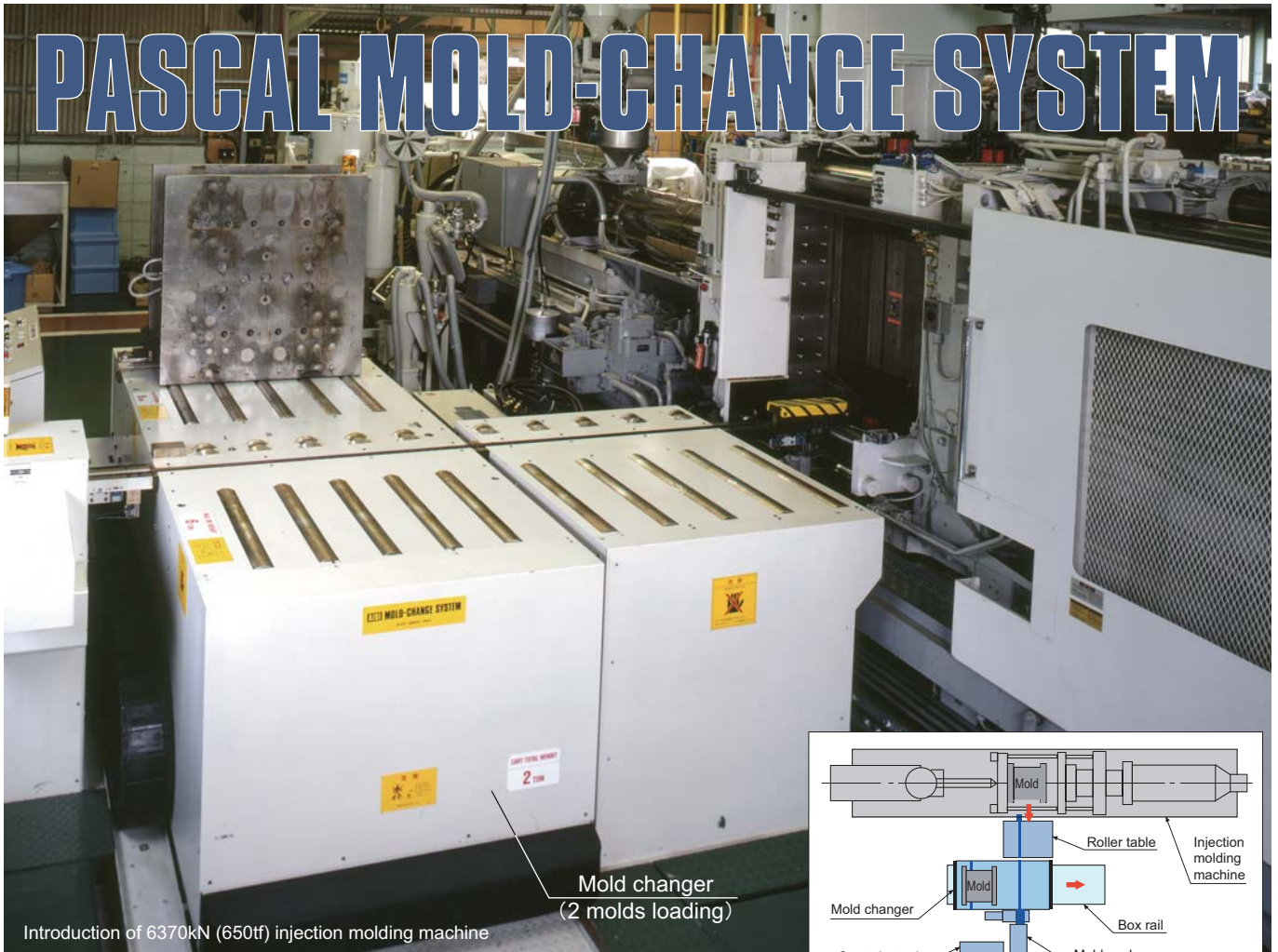

Introduction of 6370kN (650tf) injection molding machine

Mold changer
(2 molds loading)

The key to the just-in-time production

- Utilization of the Pascal Mold Change System allows complete automation from the transportation of the mold to the changeover. With this automatic changeover system a job normally taking two to four workers 30 to 60 minutes will be completed by a single operator in 3 to 5 minutes, greatly improving productivity.
- Another benefit of the system is enhanced safety because of the elimination of both dangerous operations on the platen and the tightening of bolts.
- The Pascal Mold Change System is adaptable to your existing injection molding machines to improve your manufacturing facilities. Thus, creating a more efficient and comfortable working environment.
- The Pascal Mold Change System is indispensable for stockless (Just-in-Time) production. This has been demonstrated by the adoption of more than 1,000 Pascal Mold Change Systems by leading auto and electric appliance manufacturers in worldwide.

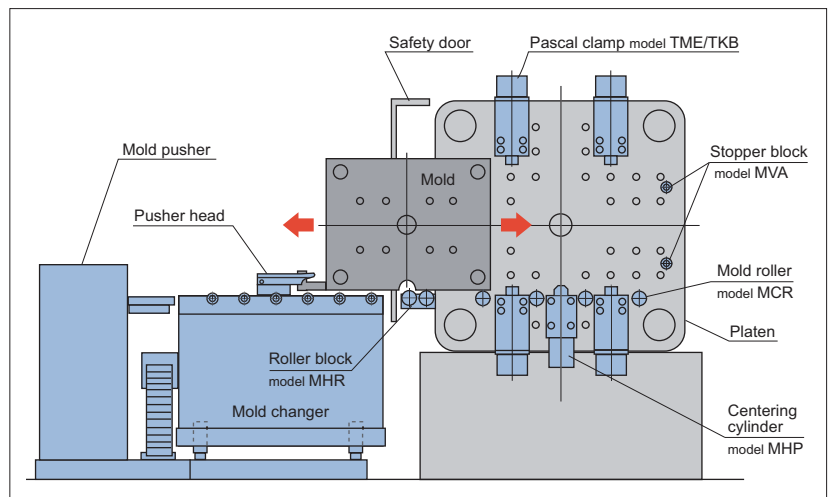

■ **Specifications**

manual · railless · mold stand type	
Clamping force of injection molding machine	294 kN (30 tf)
Max. mass of mold	150 kg x 2 molds
Max. size of mold (depth x height x width)	320 mm x 270 mm x 250 mm

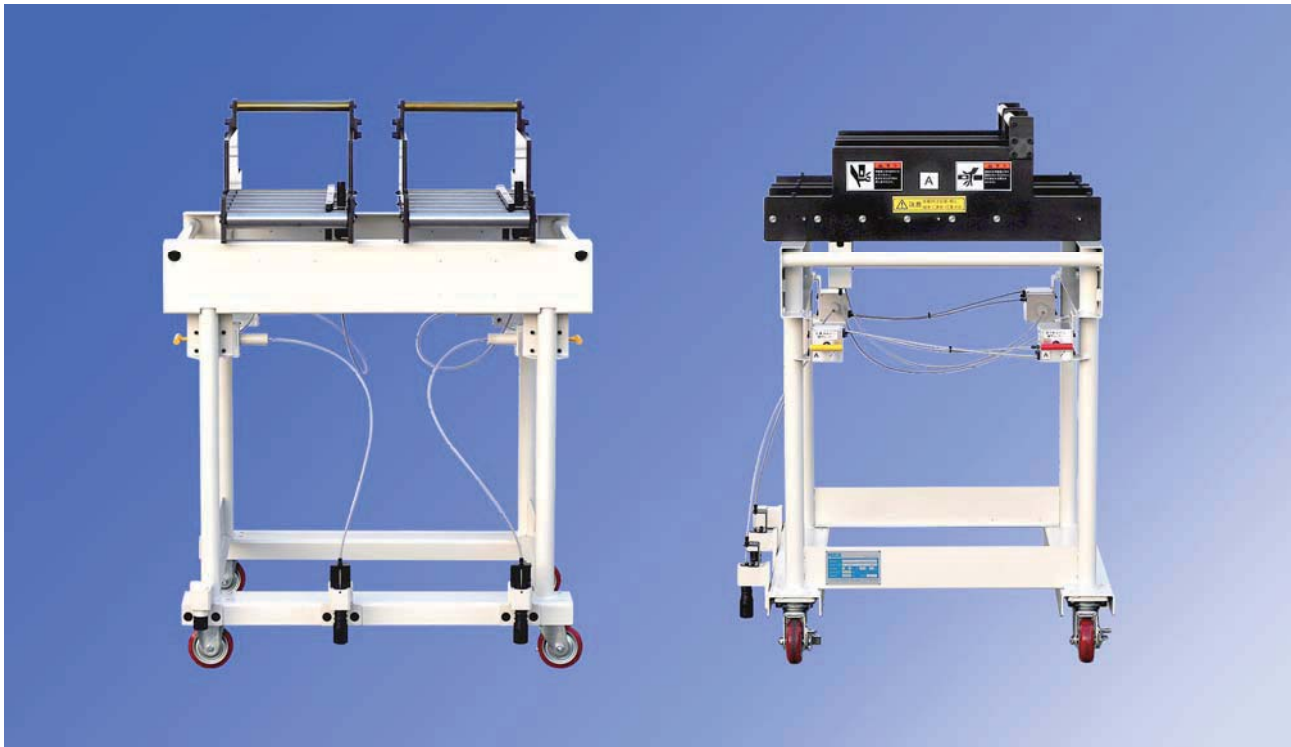

■ **System layout**

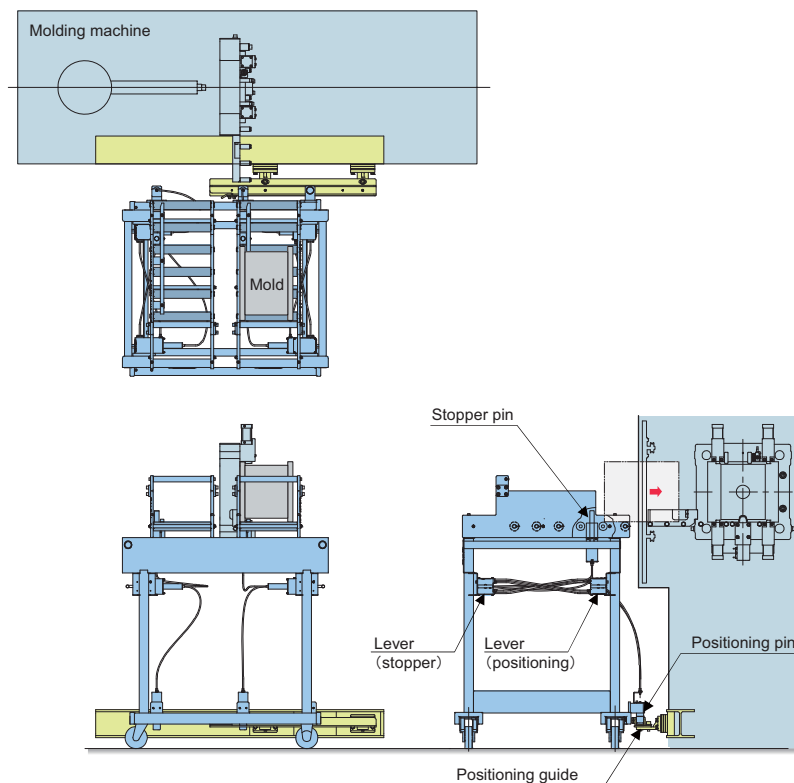

■ Specifications

manual · railless · lifting table type	
Clamping force of injection molding machine	981 kN (100 tf)
Max. mass of mold	600 kg x 1 mold
Max. size of mold (depth x height x width)	560 mm x 410 mm x 520 mm
Lifting stroke : S1	250 mm



■ System layout

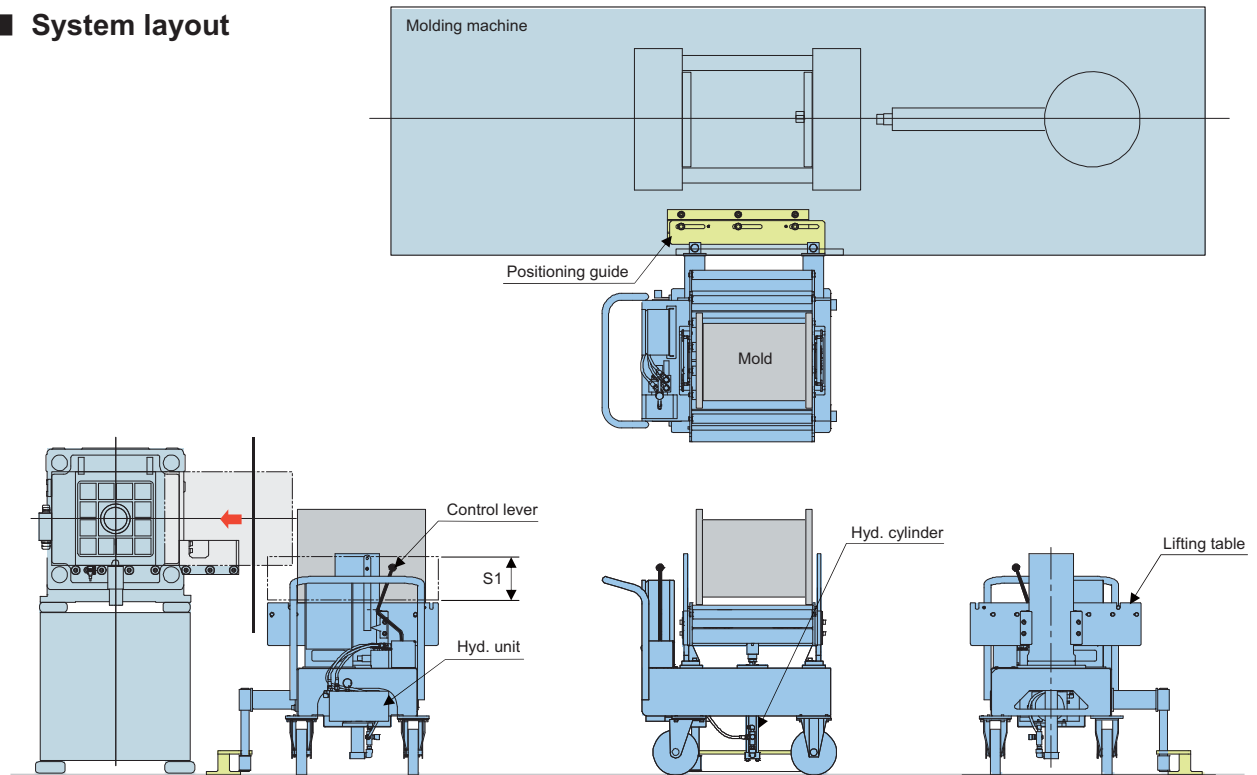

■ Specifications

automatic • railless • lifting table type		
model	QMB1-800	QMB1-1500
Max. mass of mold	800 kg x 1 mold	1500 kg x 1 mold
Max. size of mold (depth x height x width)	650mm x below tie-bar x 540mm	750mm x below tie-bar x 690mm
Lifting stroke : S1	350 mm	400 mm



■ System layout

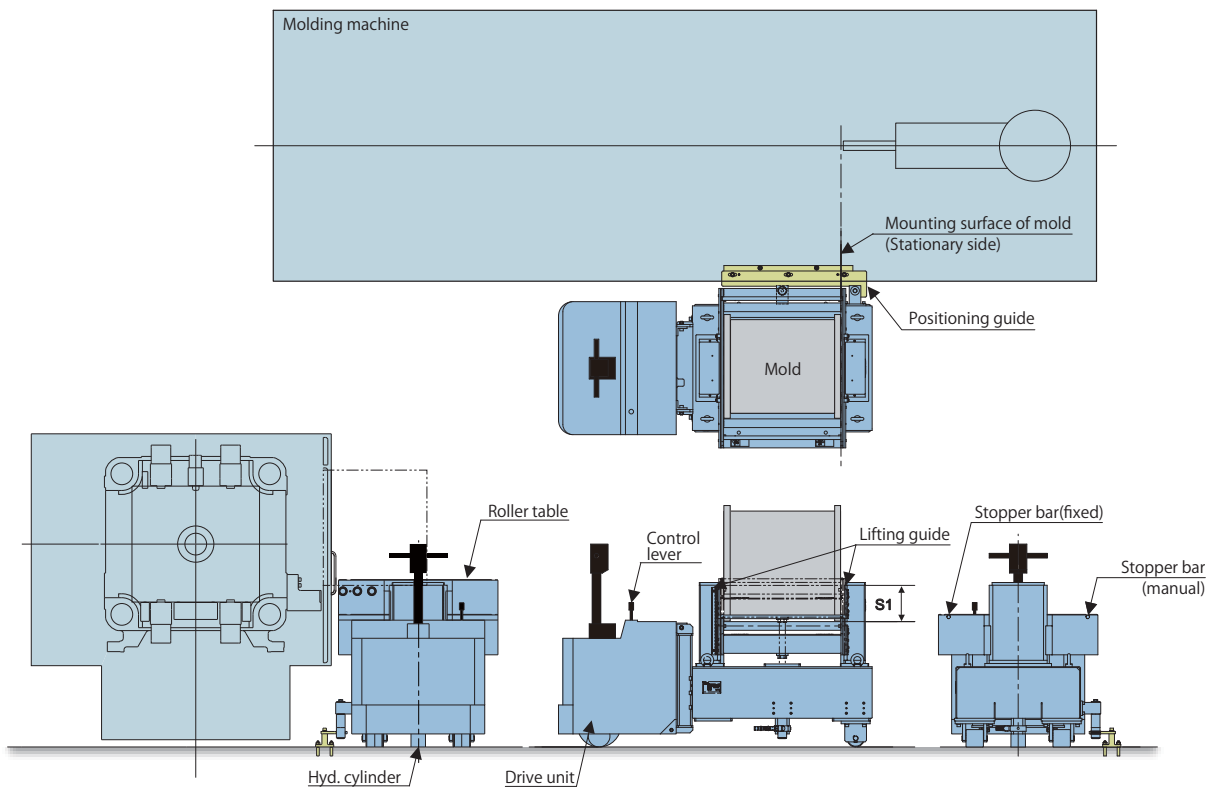

■ Specifications

manual · rail type	
Clamping force of injection molding machine	784 kN (80 tf)
Max. mass of mold	300 kg x 2 molds
Max. size of mold (depth x height x width)	450 mm x below tie-bar x 400 mm
Changer travel	1500 mm



■ System layout

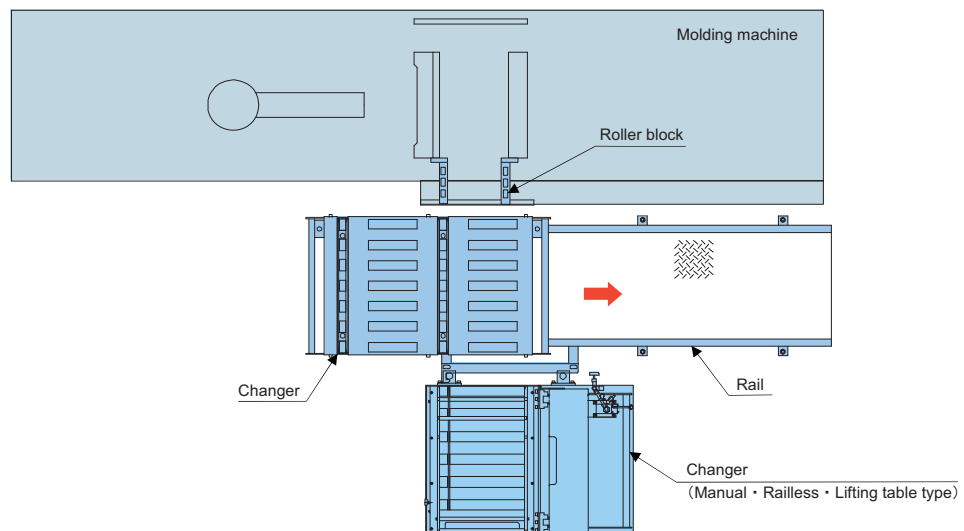

■ Specifications

manual · molding machine mounted type	
Clamping force of injection molding machine	294 kN (30 tf)
Max. mass of mold	80 kg x 2 molds
Max. size of mold (depth x height x width)	250 mm x 250 mm x 240 mm
Changer travel	395 mm



■ System layout

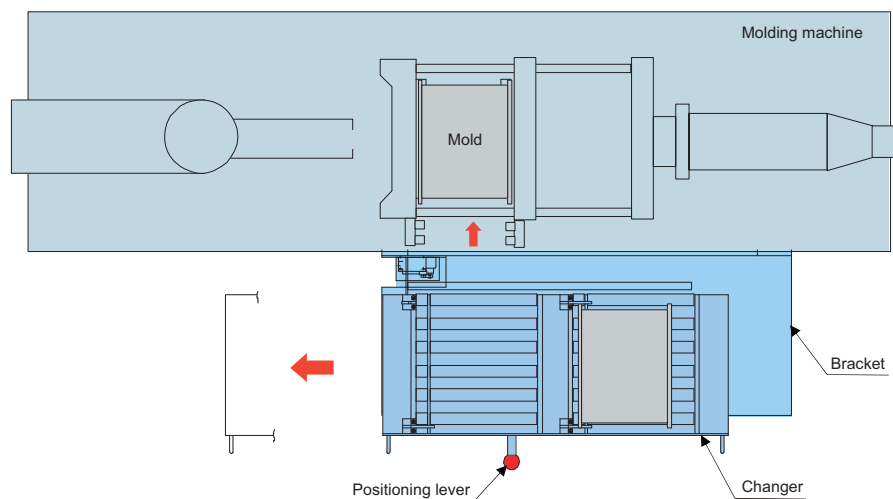

■ Specifications

automatic · molding machine mounted type	
Clamping force of injection molding machine	588 kN (60 tf)
Max. mass of mold	300 kg x 2 molds
Max. size of mold (depth x height x width)	400 mm x 400 mm x 300 mm
Changer travel	500 mm

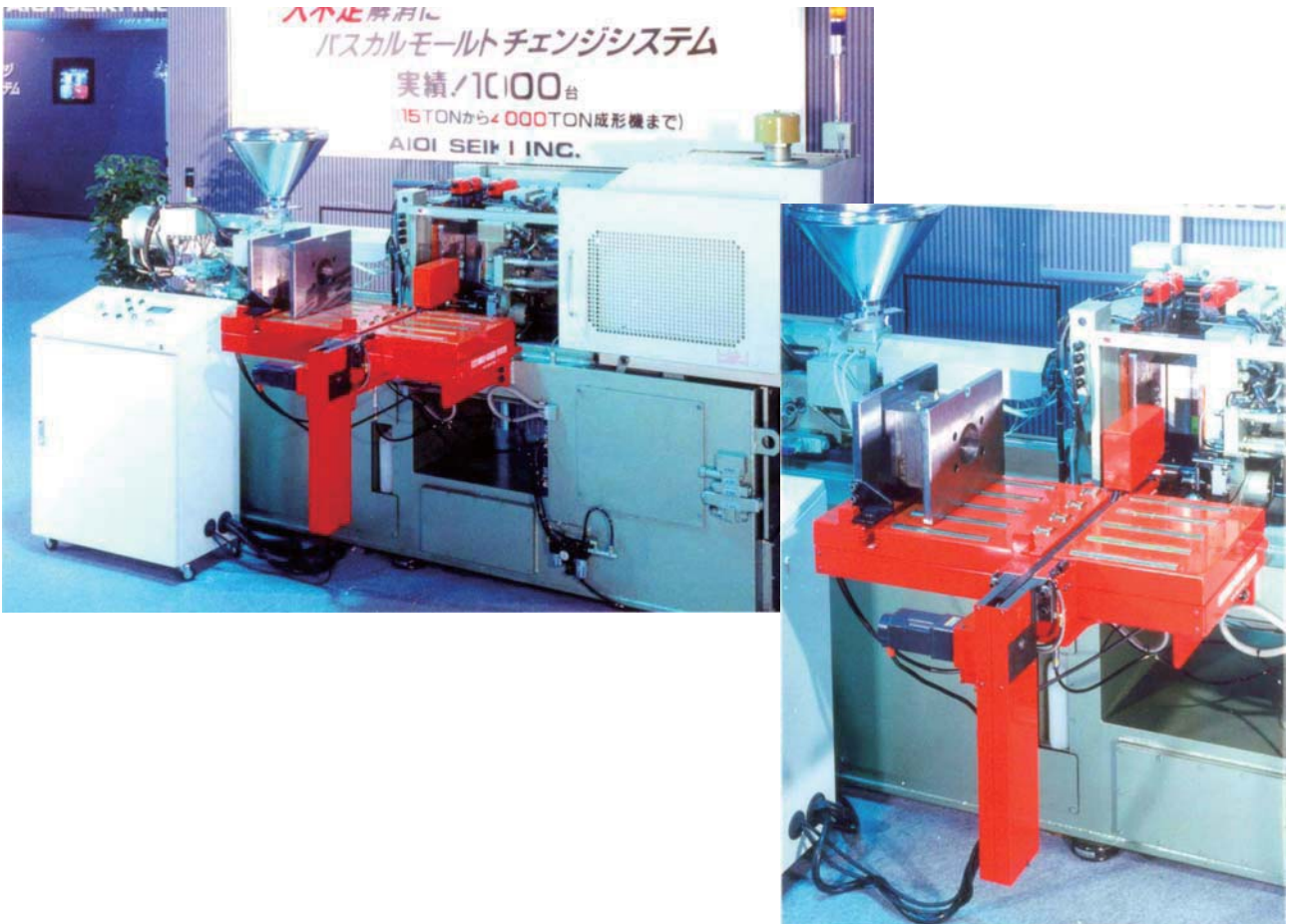

■ System layout

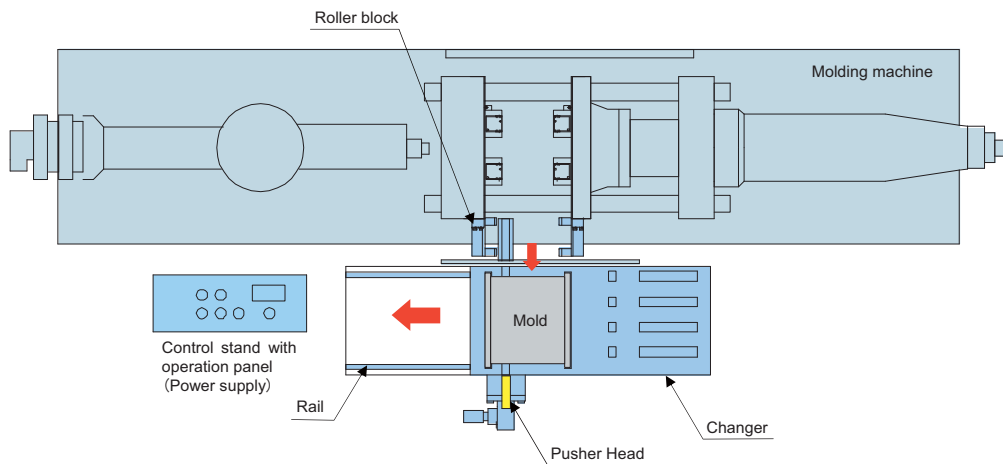

■ Specifications

automatic · pusher stand type	
Clamping force of injection molding machine	6374 kN (650 tf)
Max. mass of mold	6 ton x 2 molds
Max. size of mold (depth x height x width)	840 mm x 940 mm x 1000 mm
Changer travel	1300 mm

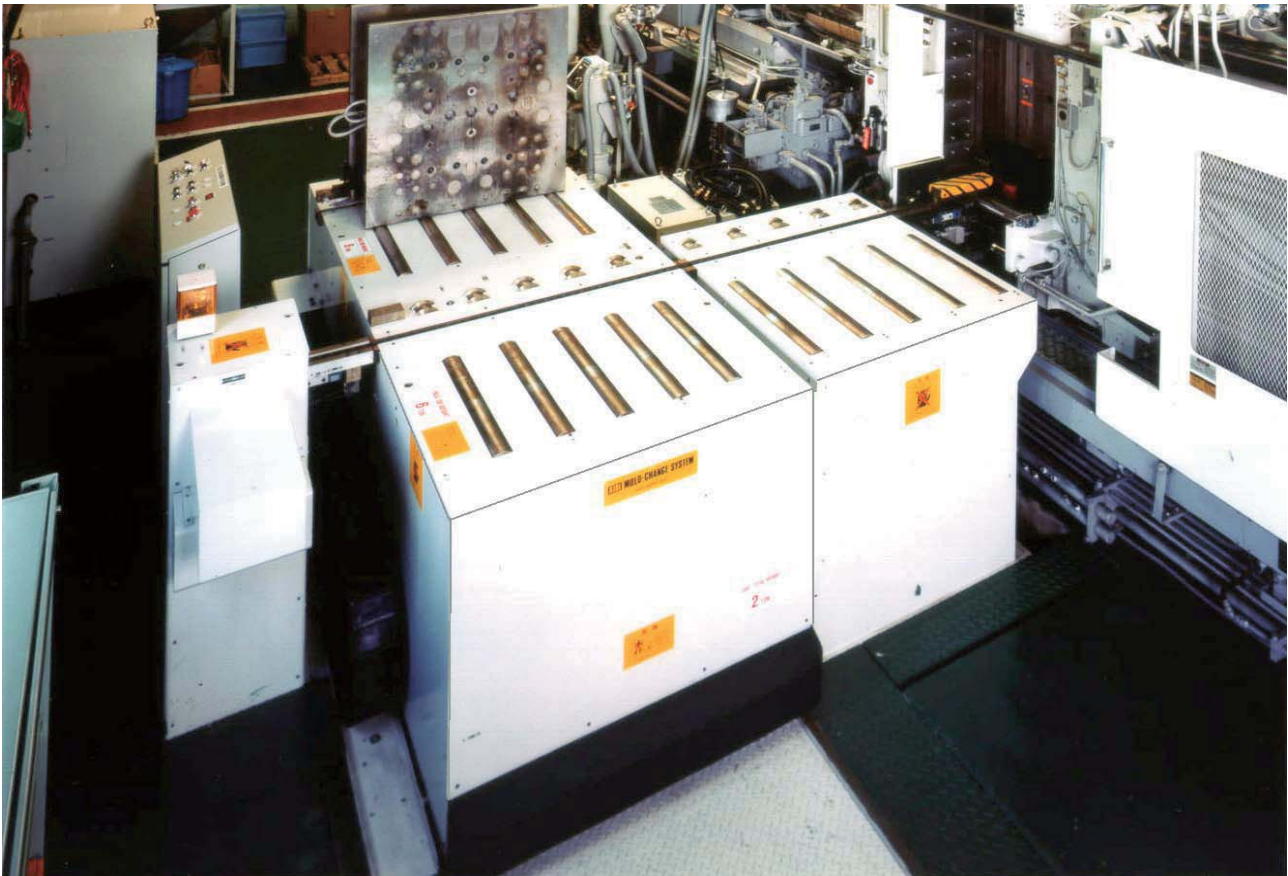

■ System layout

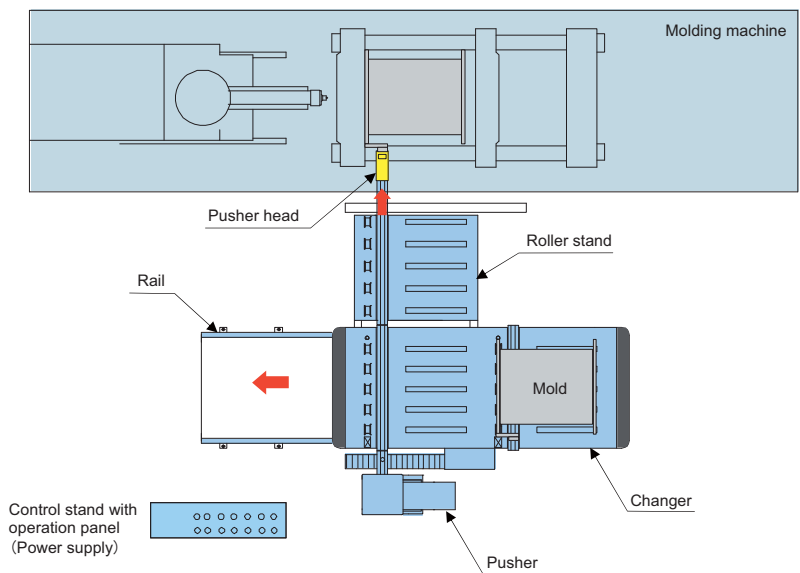

■ Specifications

automatic · pusher mounted type	
Clamping force of injection molding machine	6374 kN, 12745 kN (650 tf, 1300 tf)
Max. mass of mold	15 ton x 2 molds
Max. size of mold (depth x height x width)	1600 mm x 1180 mm x 1500 mm
Changer travel	32 m

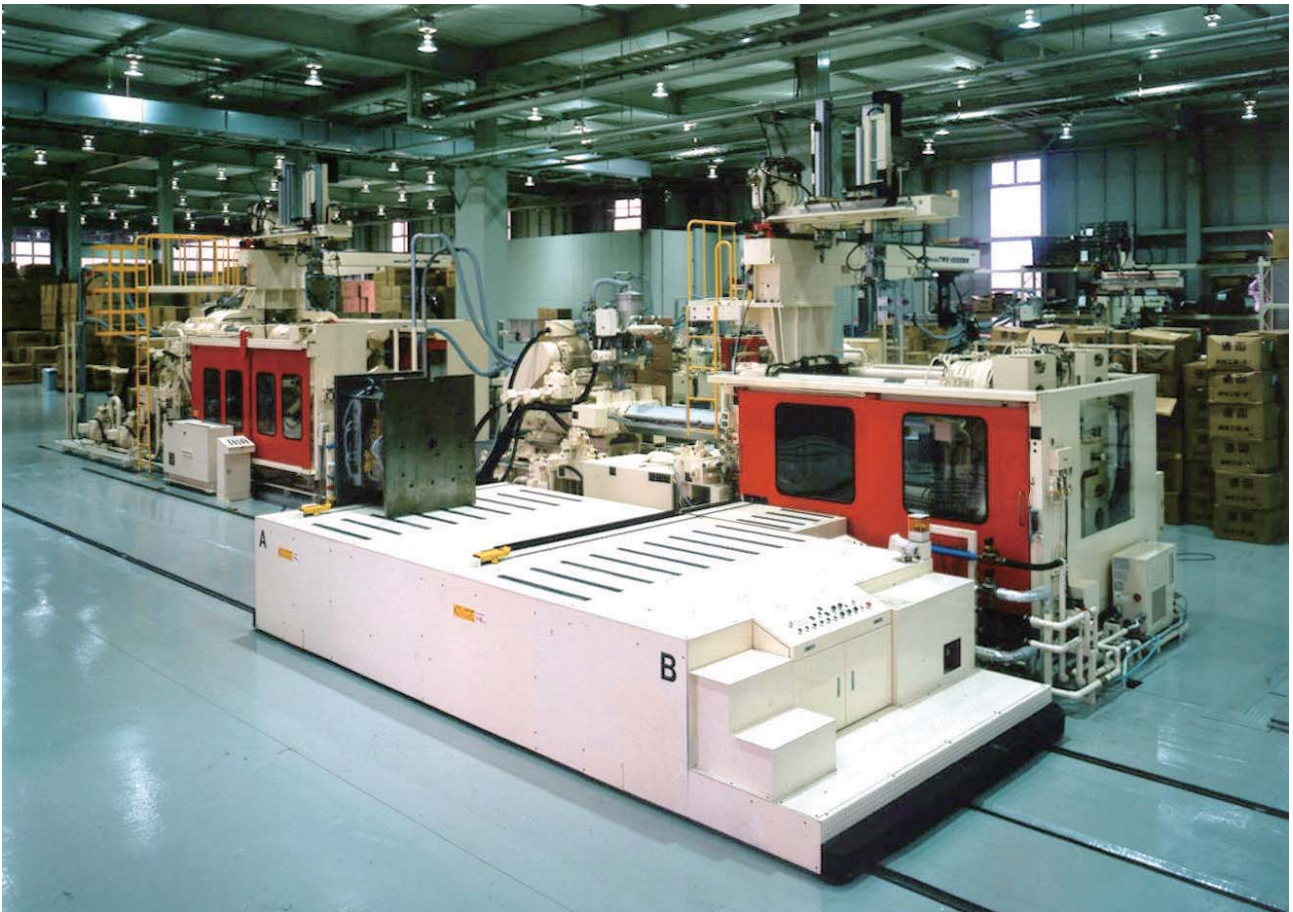

■ System layout

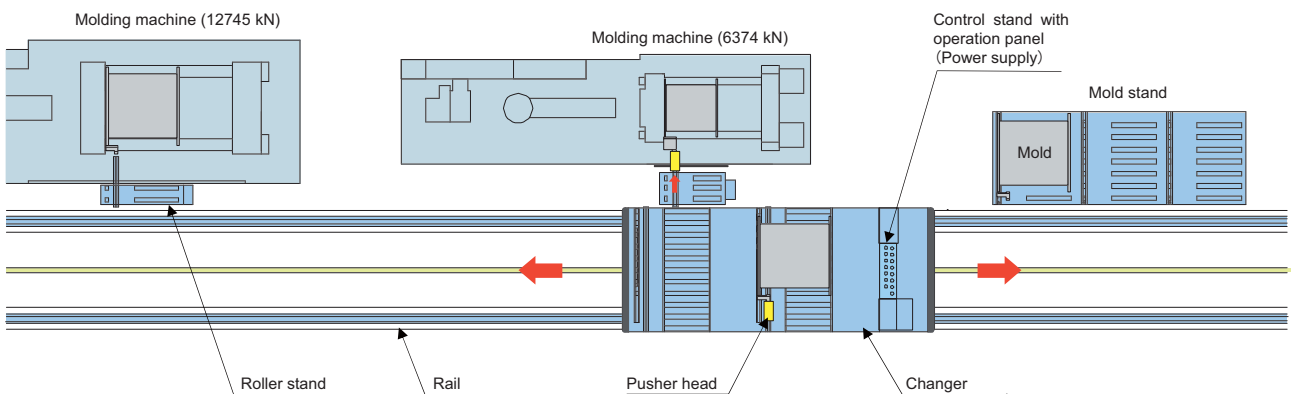

■ Specifications

automatic · pusher mounted · opposed type	
Clamping force of injection molding machine	6374 kN, 8335 kN (650 tf, 850 tf)
Max. mass of mold	7 ton x 2 molds
Max. size of mold (depth x height x width)	1200 mm x 900 mm x 1400 mm
Changer travel	24 m

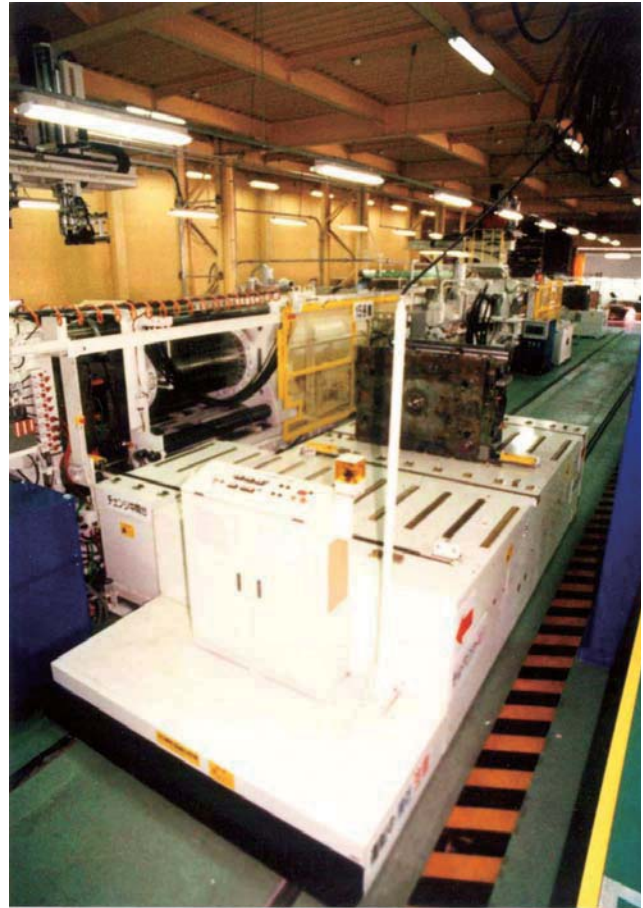

■ System layout

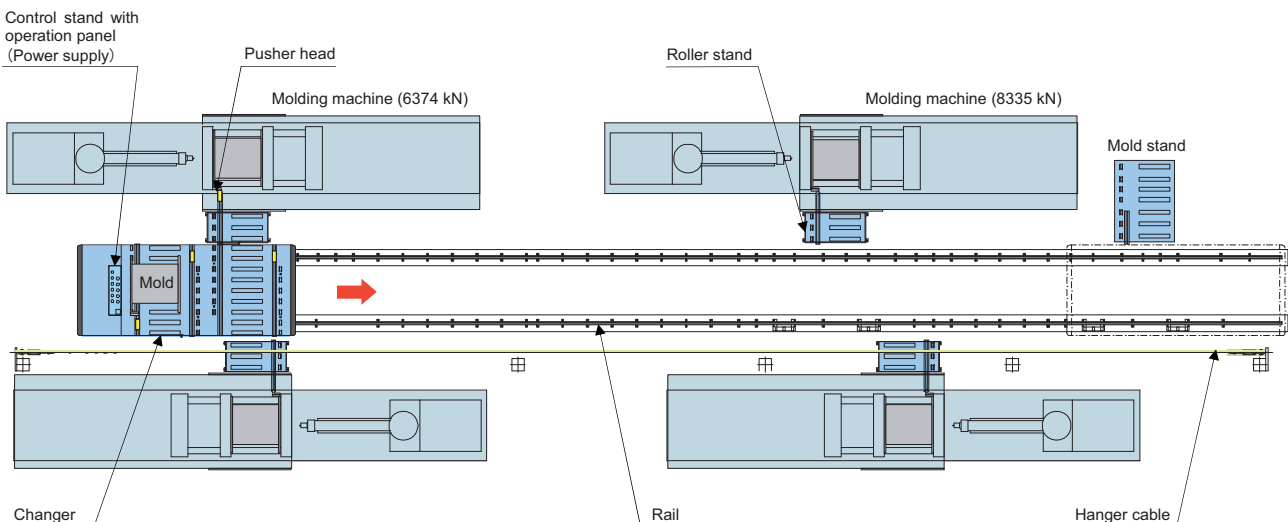

■ **Specifications**

automatic • pusher mounted • opposed type	
Clamping force of injection molding machine	12745 kN (1300 tf)
Max. mass of mold	40 ton x 2 molds
Max. size of mold (depth x height x width)	1800 mm x 1300 mm x 1200 mm
Changer travel	22 m



■ **System layout**

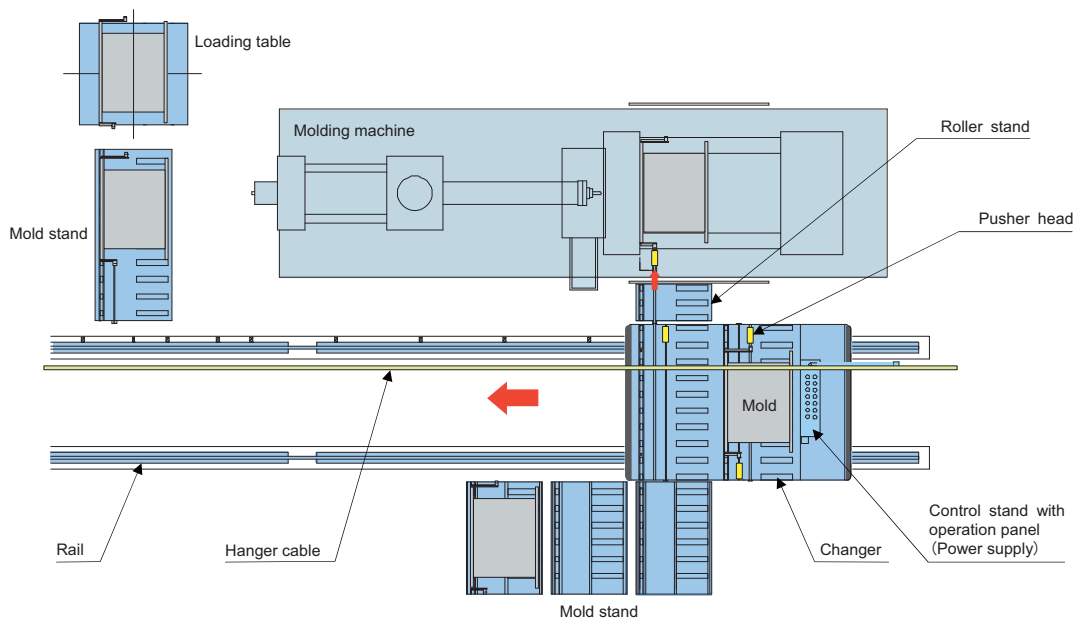

■ Specifications

	automatic · driving roller type	
Clamping force of injection molding machine	15690 kN (1600 tf)	
Max. mass of mold	10 ton x 2 molds	
Max. size of mold (depth x height x width)	2100 mm x 1400 mm x 1500 mm	
Changer travel	16 m	

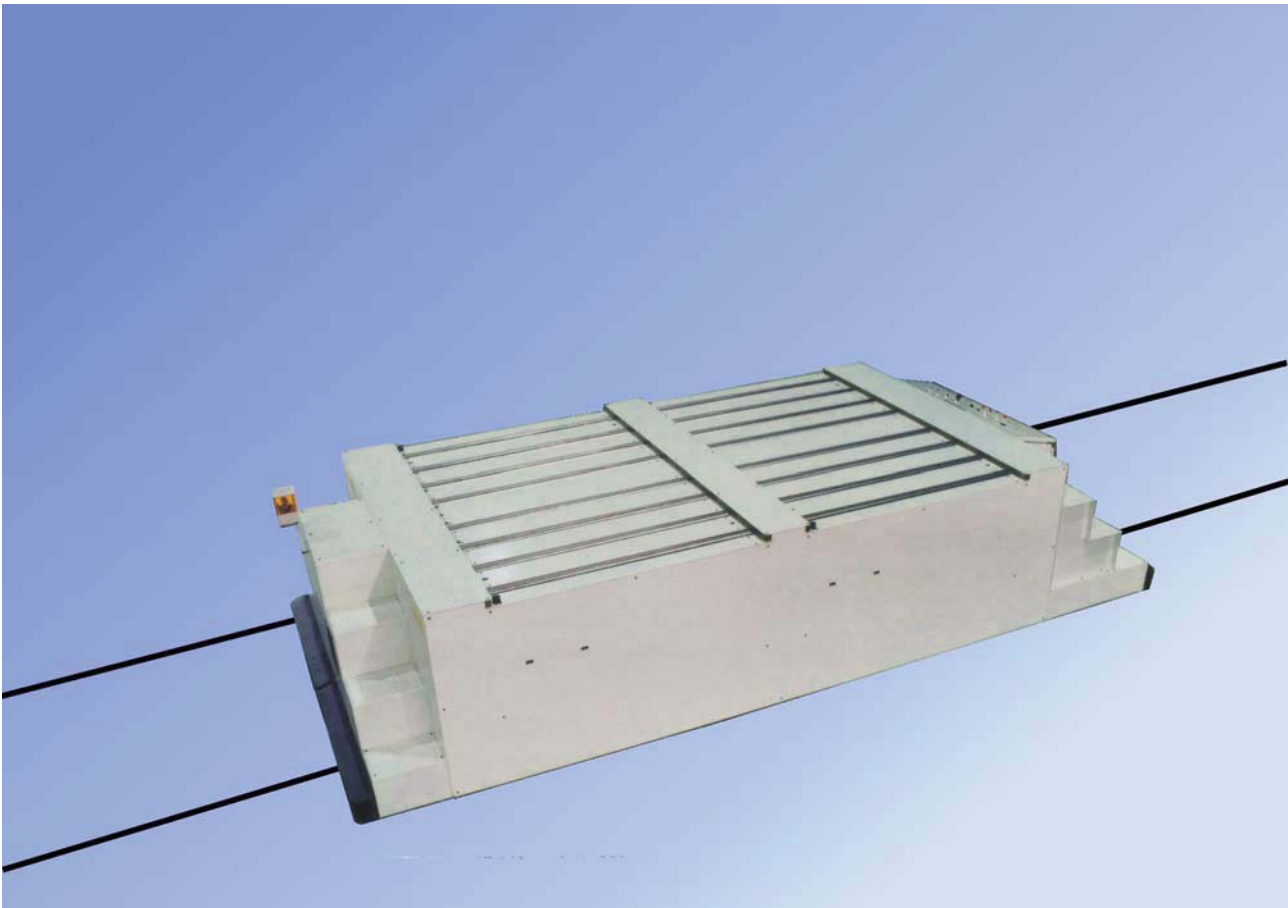

■ System layout

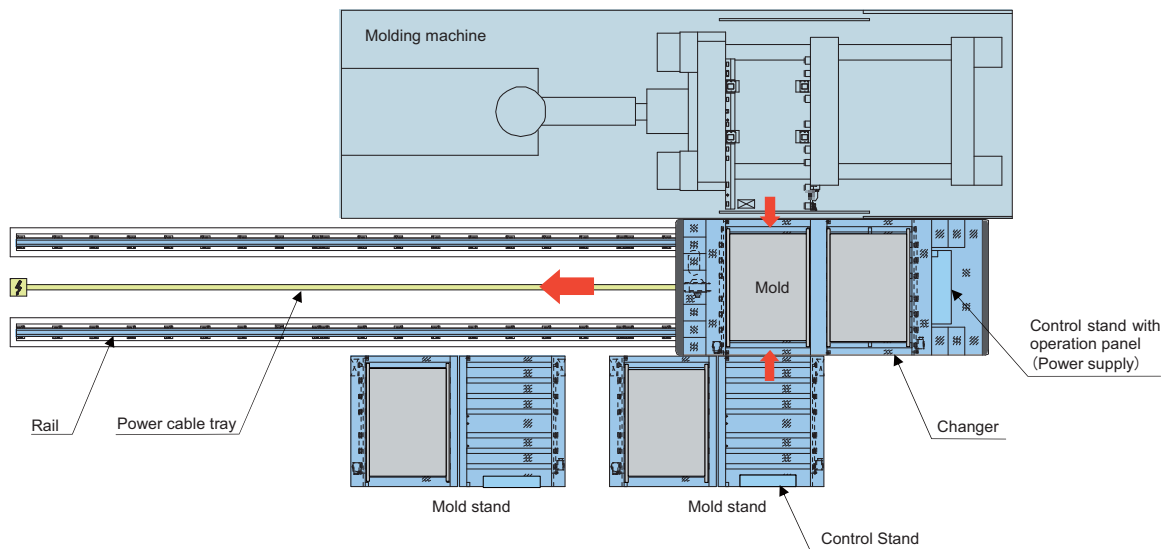

■ Specifications

mold stand · pusher handle type	
Clamping force of injection molding machine	5394 kN (550 tf)
Max. mass of mold	4 ton x 1 mold
Max. size of mold (depth x height x width)	1300 mm x 840 mm x 800 mm
Mold travel	1890 mm



■ System layout

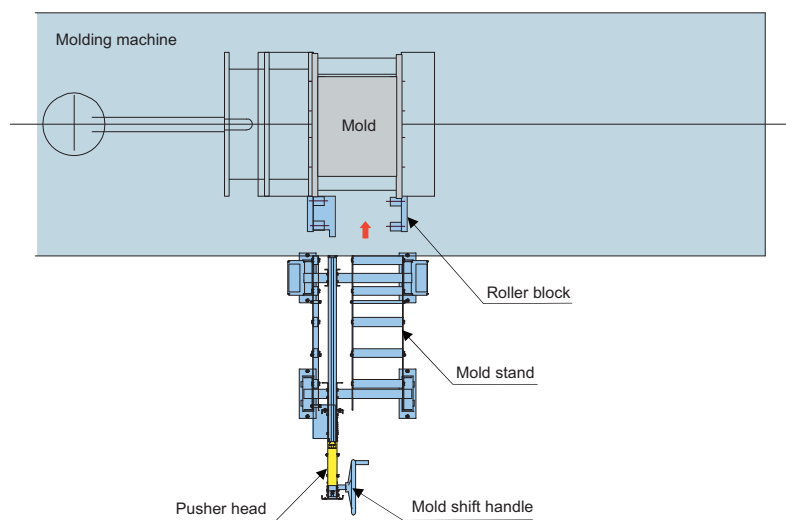

■ Specifications

mold stand · pusher mounted type	
Clamping force of injection molding machine	39200 kN (4000 tf)
Max. mass of mold	40 ton x 1 mold
Max. size of mold (depth x width)	3000 mm x 1600 mm
Mold travel	4.4 m

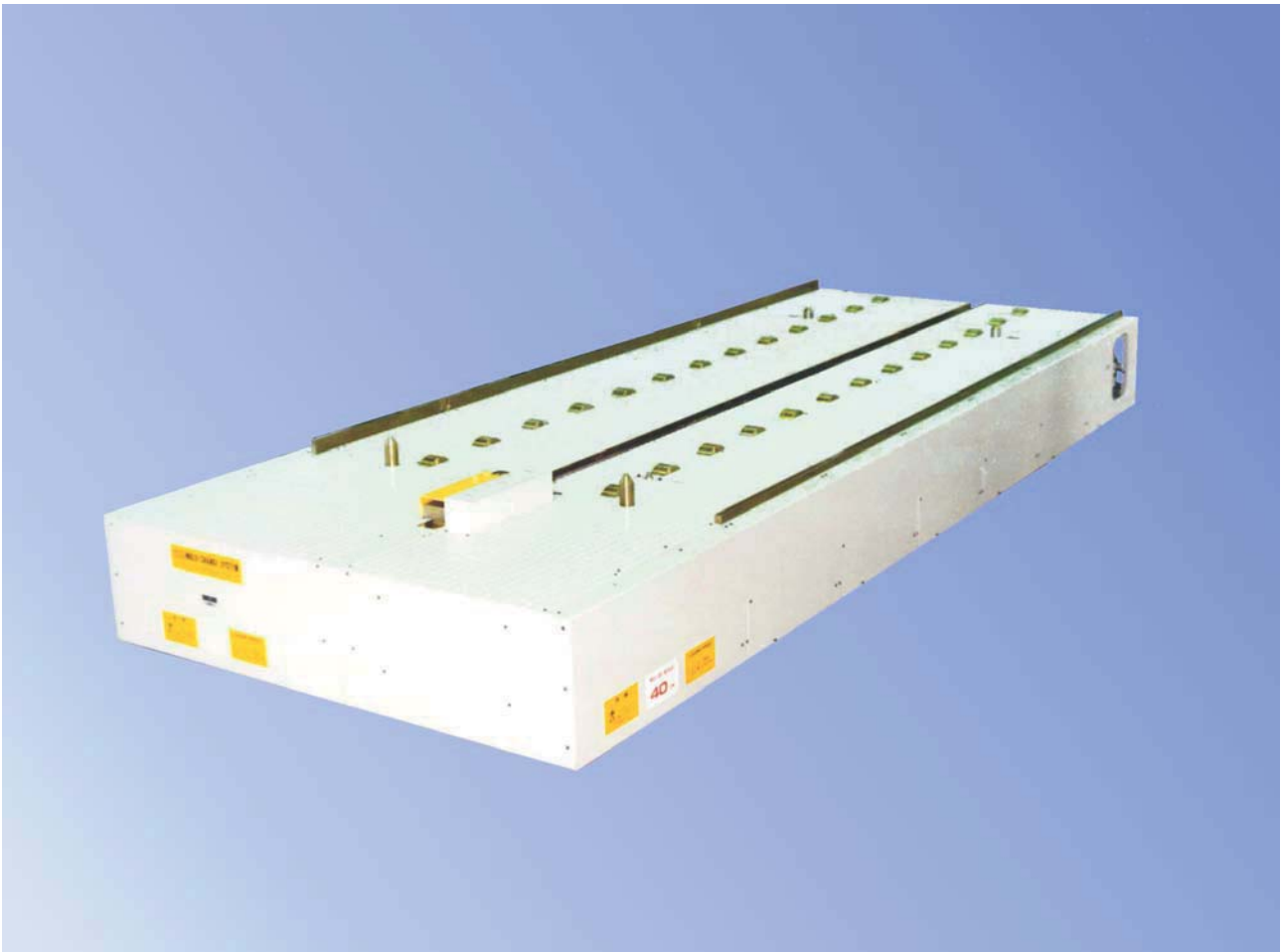

■ System layout

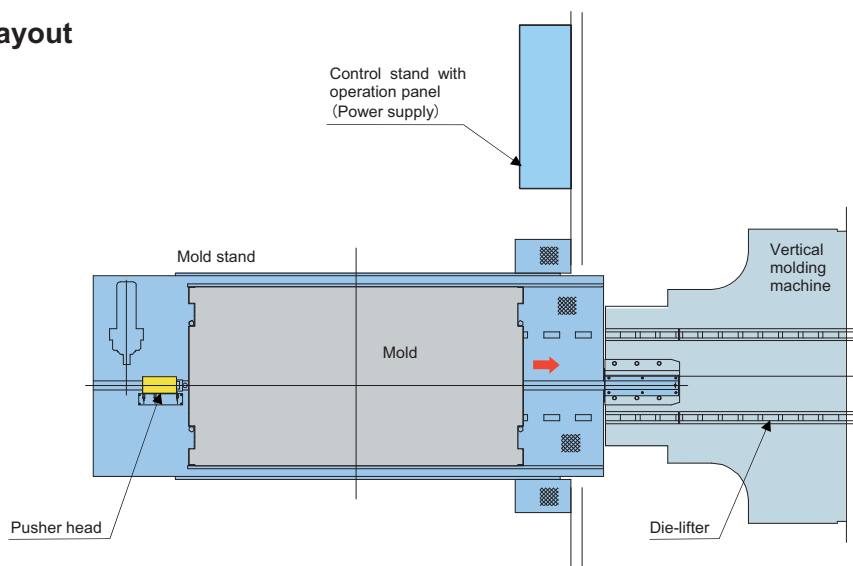

Pascal

corporation

Itami, Hyogo, Japan 664-8502
TEL.(072)777-3333 FAX.(072)777-3520

