

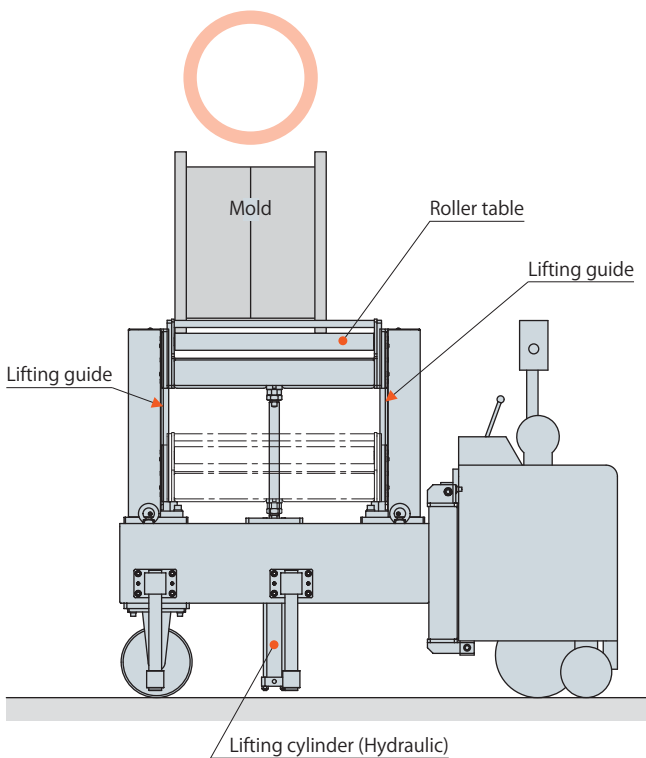

**Lifting guides on front and back side of column improve the stability of roller table, which enables mold change operation safer and easier.**

**Pascal** model **QMB**



**Other supplier's model**

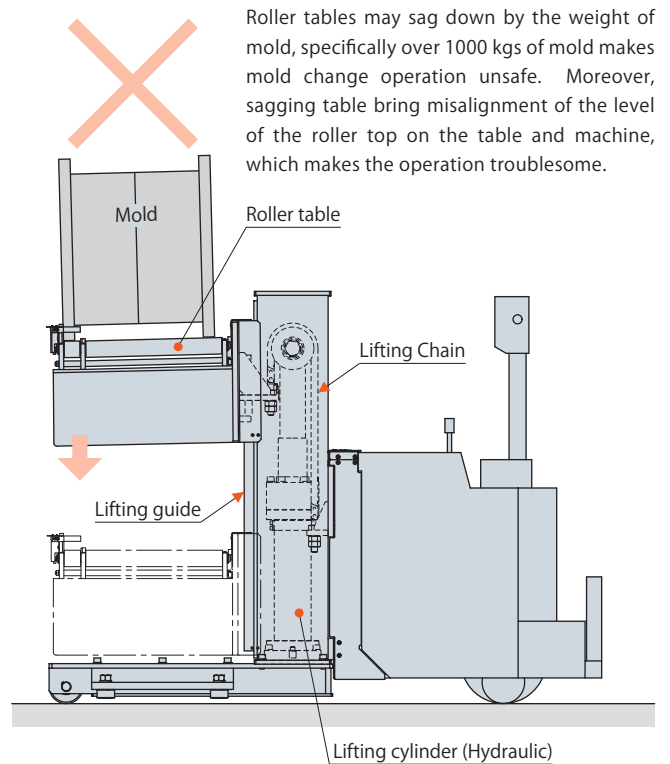

■ Specifications

automatic • railless • lifting table type		
model	QMB1-800	QMB1-1500
Max. mass of mold	800 kg x 1 mold	1500 kg x 1 mold
Max. size of mold (depth x height x width)	650mm x below tie-bar x 540mm	750mm x below tie-bar x 690mm
Lifting stroke : S1	350 mm	400 mm



■ System layout

