

PASCAL[®]

MOLD-CHANGE

SYSTEM

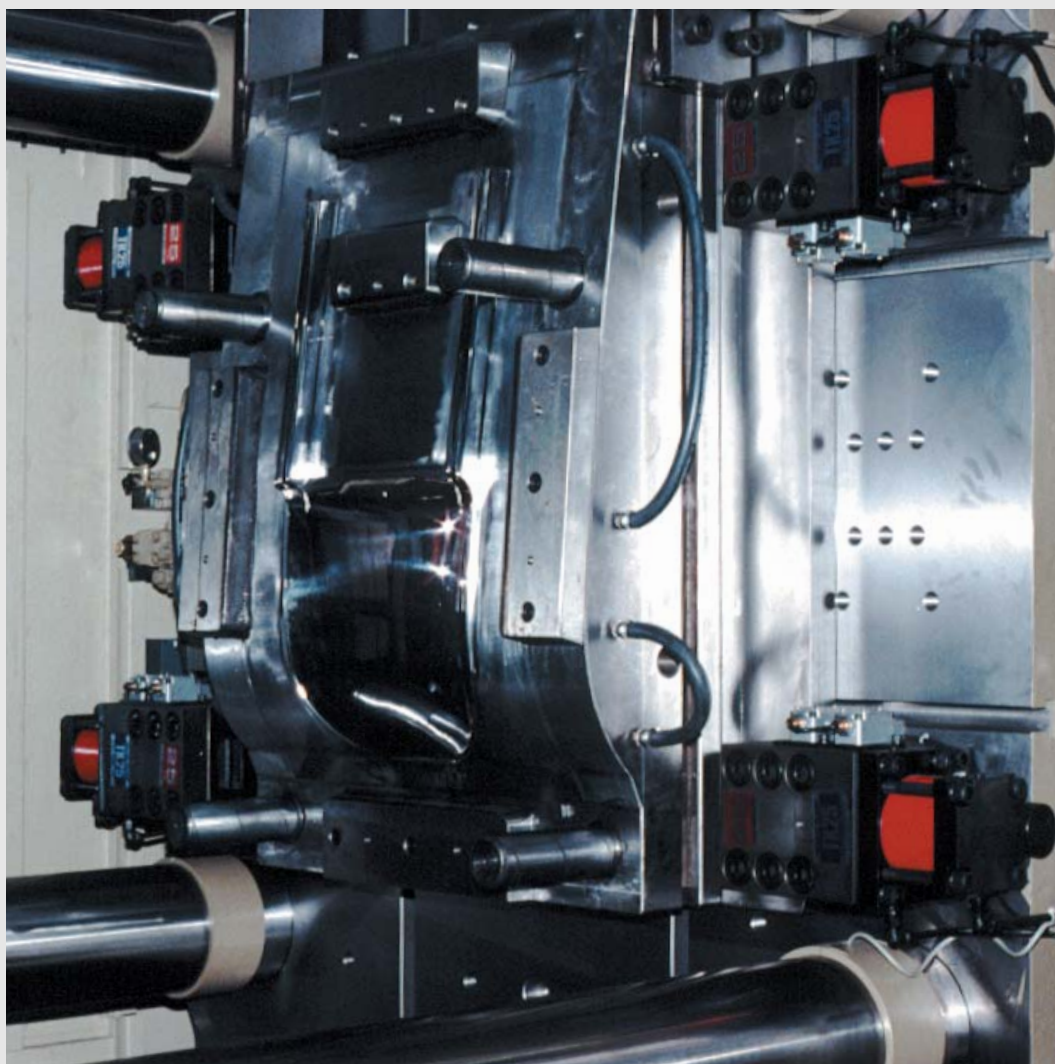

Pascal
corporation

www.pascaleng.co.jp

PASCAL QUICK MOLD CHANGE SYSTEM

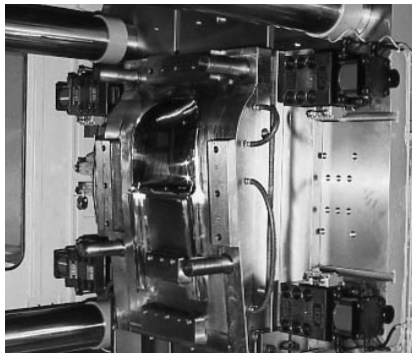

SYSTEM IVK

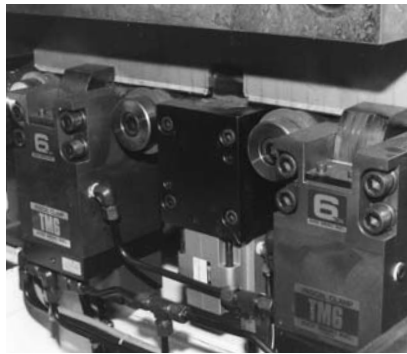

SYSTEM IHM



QMC-Small Size

It is a must for the injection molders that their plant operation be capable of compromising the needs of decreasing production lot and increasing variation of products, and at the same time shortening of delivery and lowering the production cost.

PASCAL offers its reliable, durable, unique and cost efficient Quick Mold Change System in accordance with individual system requirements and customer specific conditions.

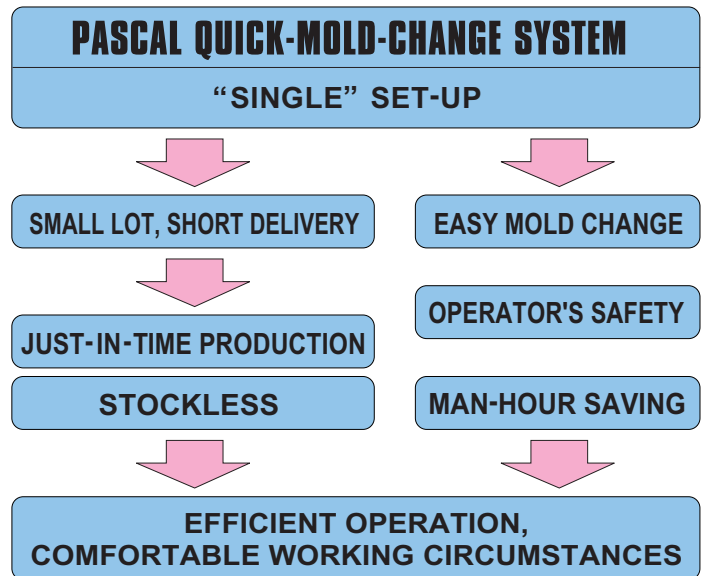

FOR INJECTION MOLDING MACHINE

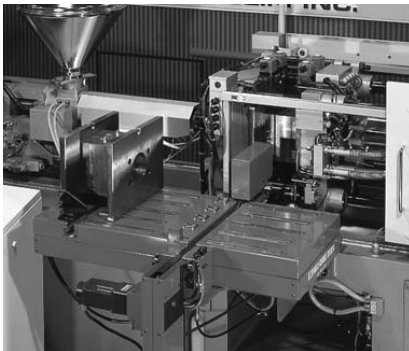

QMC-Small Size



QMC-Medium Size

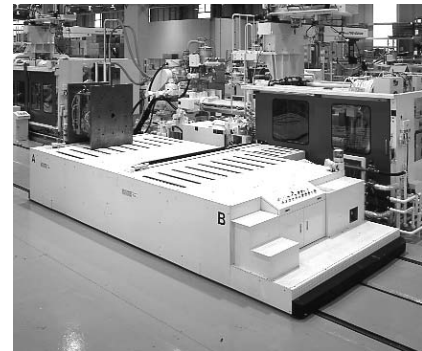

QMC-Large Size

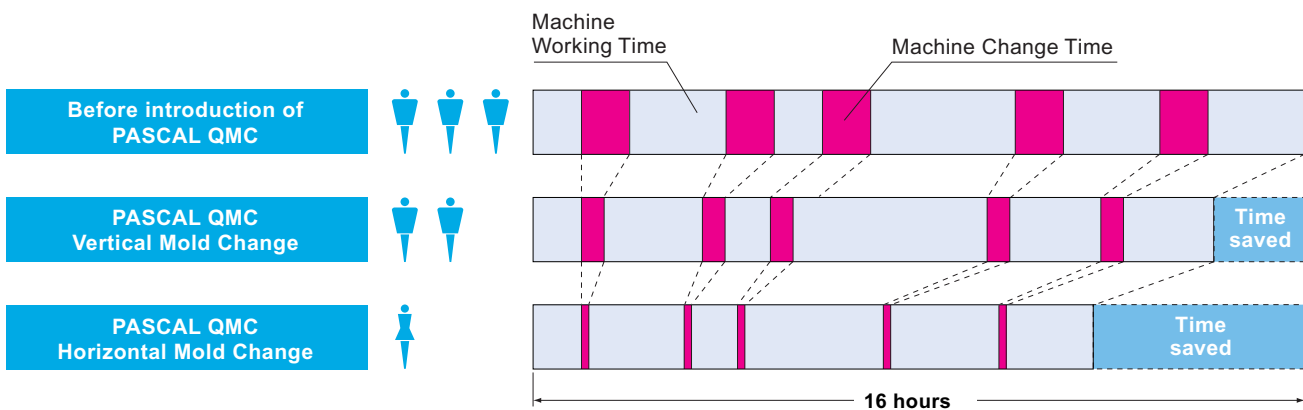

In the most successful cases :

PASCAL QMC Vertical reduced the mold change time from 60 minutes to 30 minutes.

PASCAL QMC Horizontal further reduced the time down to 5 minutes.

In the line where the molds were replaced 5 times per day, eventually 30% of downtime was saved for other works.

A total success is brought to the business from drastic cut of costs in time and man power.

PASCAL QUICK MOLD CHANGE SYSTEM PROMISES

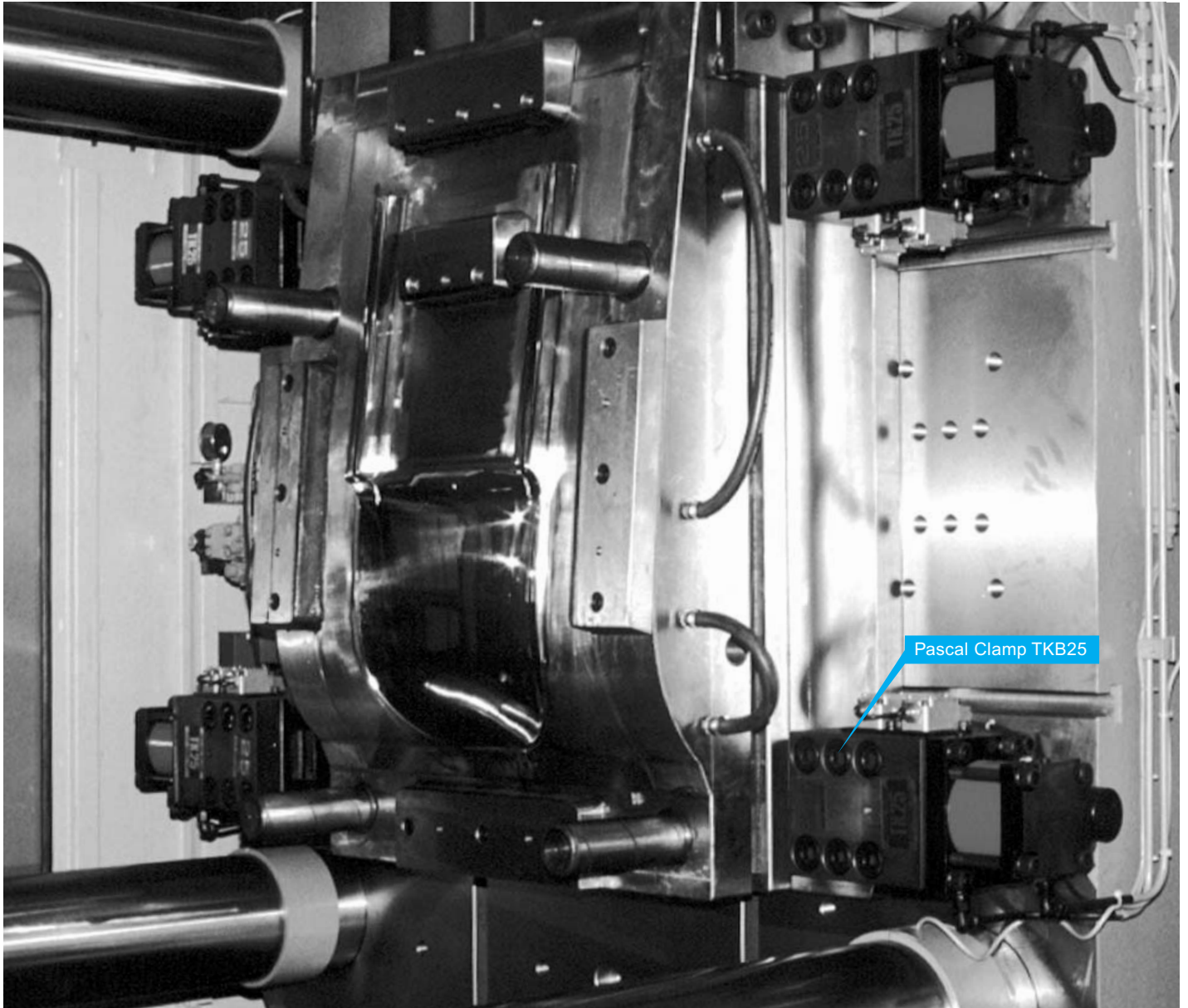

Pascal Clamp TKB25

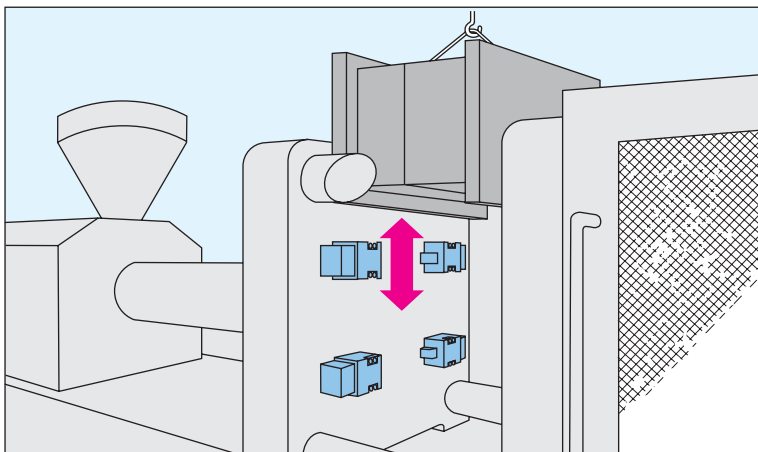

Traditional mold change operation needs skilled operators that are forced to work under hot and dangerous conditions.

PASCAL Quick Mold Change Systems can avoid this traditional problem. Operators can avoid tightening heavy bolts in narrow spaces, often between two platens. Operators can just press a button and fix the mold to the machine.

PASCAL Quick Mold Change System has continuously been adopted by many injection molders worldwide.

DRAMATIC INCREASE OF PRODUCTIVITY

PASCAL VERTICAL MOLD CHANGE

Vertical Mold Change by means of a crane is the simplest method and can be equipped with minimum investment cost.

SYSTEM IVM (IVK)

When the width of the molds is unified, system IVM or IVK is applicable. Retracting lever clamp model TME is used for System IVM, which is suitable for small to medium size injection molding machines. Model TKB is used for System IVK, which is good for large machines.

MODEL TME

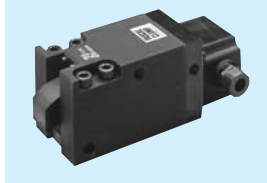

MODEL TKB



SYSTEM IVY (IVX)

When the width of the molds cannot be unified, system IVY or IVX is applicable. System IVY or IVX contains T-slotted plate to be fixed on to both platens and Pascal Auto-Slide clamp TYC-R or Pascal Manual-Slide clamp TYA respectively are installed.

MODEL TYA



MODEL TYC-R



For the introduction of Pascal vertical mold change system, it is necessary to unify the thicknesses of the clamp plate as well as the U-cut for centering block of all the molds. When installing a T-slot plate, the decrease of daylight and the relocation of nozzle touch position should be minded.

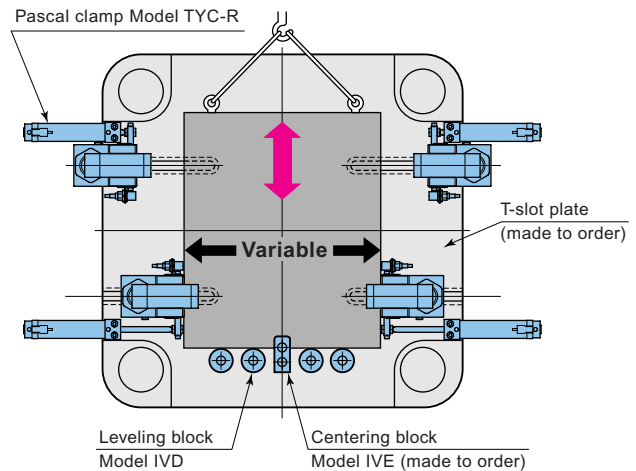
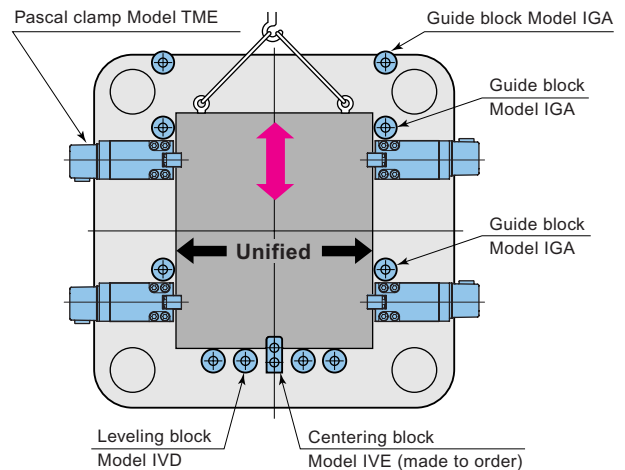

SELECTION OF CLAMP SYSTEM

Injection Molding Machine		System IVM · IVK (TME · TKB clamp)		System IVY · IVX (TYA · TYC clamp)				U-cut dimension for positioning block		T-slot dimension for System IVY(IVX)	
Mold clamp Force (kN)	Mold opening Force (kN)	Model × No.Req.	Applicable Control Unit	Model × No.Req.	Applicable Control Unit	T-slot dimension (mm)					
						a	b	d	j	m (mm)	n (mm)
~ 500	39.2	TME1 × 8	HCFD-3CSSS	TYA 1 × 8	HCFD-2SSS	18 ^{+0.5} ₀	30 ⁺² ₀	18 ^{+0.2}	12 ⁺² ₀	30 ^{+0.10} ₀	30
~ 1000	78.4	TME2.5 × 8		TYA 2 × 8		22 ^{+0.5} ₀	37 ⁺³ ₀	22 ^{+0.2}	16 ⁺² ₀		
~ 1500	98.0	TME4 × 8	TYA 4 × 8	28 ^{+0.5} ₀		46 ⁺⁴ ₀	28 ^{+0.2}	20 ⁺³ ₀	60 ^{+0.12} ₀	35	
~ 2000	156	TME6 × 8	TYA 6 × 8	32 ^{+0.5} ₀		53 ⁺⁴ ₀	28 ^{+0.2}	24 ⁺³ ₀	100 ^{+0.14} ₀		40
~ 3500	247	TME10 × 8	TYA10 × 8	HCFD-2SSS	HCFD-2SSS					140 ^{+0.16} ₀	
~ 5500	392	TME16(TME10) × 8	TYA16 × 8								HCFD-2SSS
~ 6500	627(392)	TME16(TKB16) × 8	TYA16 × 8	HCFD-2SSS	HCFD-2SSS						
~ 8500	627	TKB25 × 8	TYA25 × 8								HCFD-2SSS
~ 13000	980	TKB40 × 8	TYA25 × 8	HCFD-2SSS	HCFD-2SSS						
~ 30000	1569	TKB40 × 8	TYA25 × 8								HCFD-2SSS

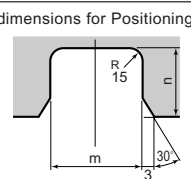
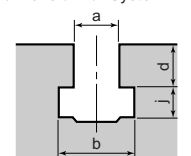

If location ring is used for positioning, the mold positioning block and U-cut are not necessary.

※Above mold opening forces are for reference. Inquire the clamp selection, when the actual mold opening force is greater than above value.

PASCAL QUICK MOLD CHANGE SYSTEM PROMISES

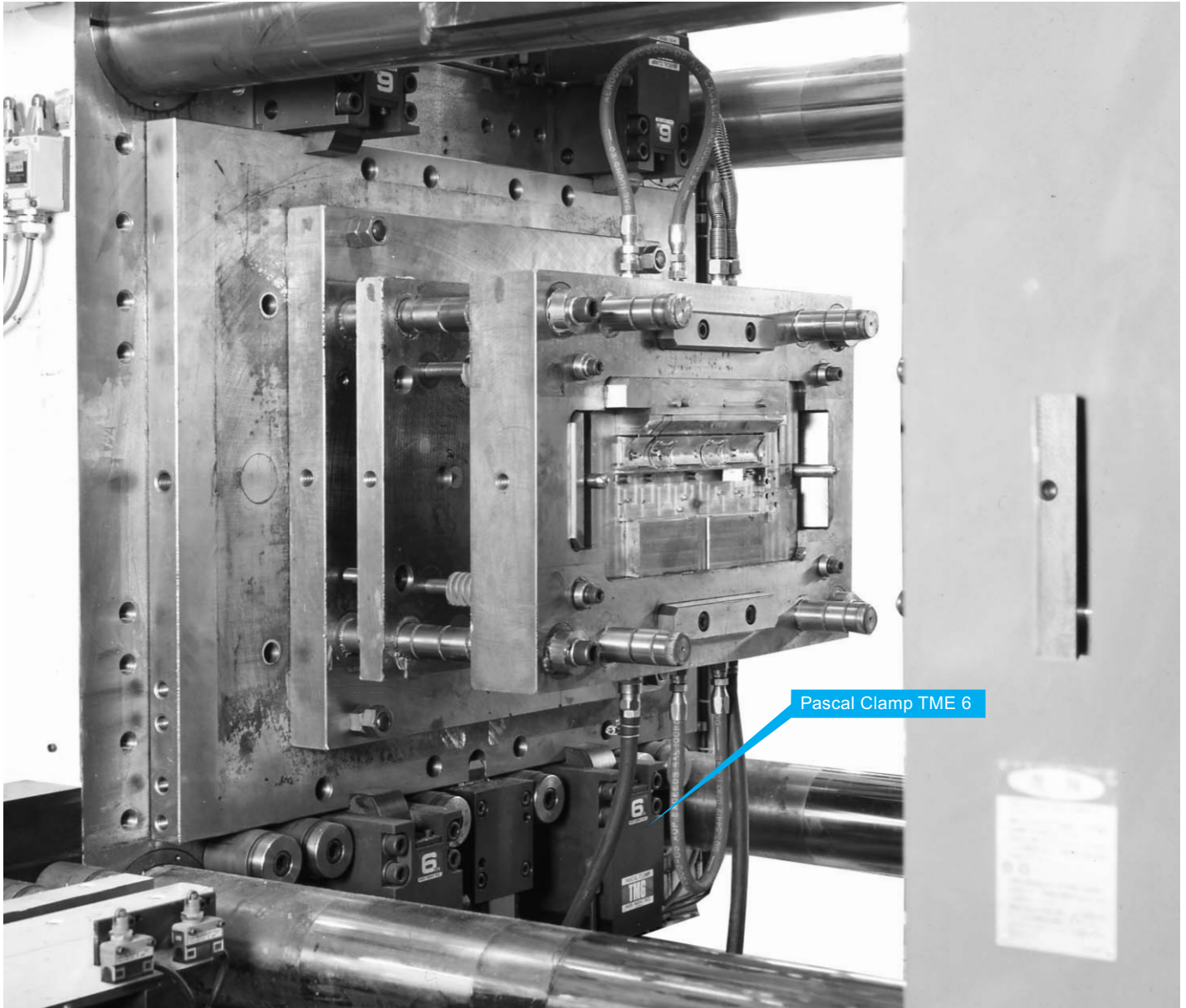

Pascal Clamp TME 6

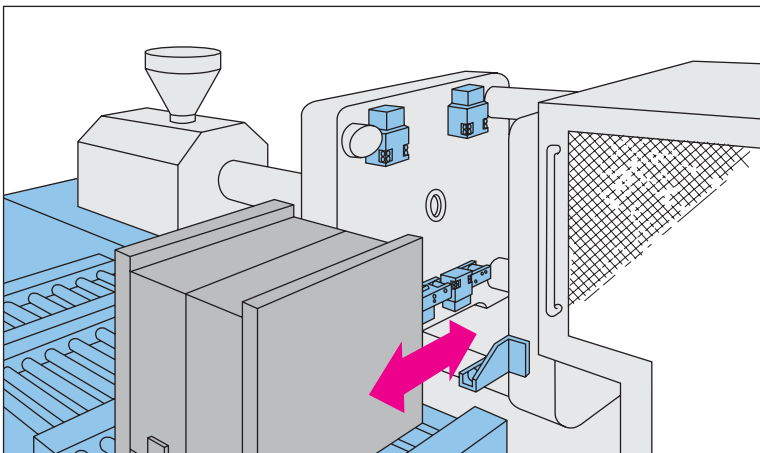

PASCAL Horizontal Mold Change System has been developed for quicker and safer mold changing operation than the Vertical Mold Change System. It can eliminate the use of the crane during mold change operation, this idle time or down time of injection machines due to crane availability can be omitted.

SUBSTANTIAL REDUCTION OF MACHINE DOWN-TIME

PASCAL HORIZONTAL MOLD CHANGE

SYSTEM IHM (IHK)

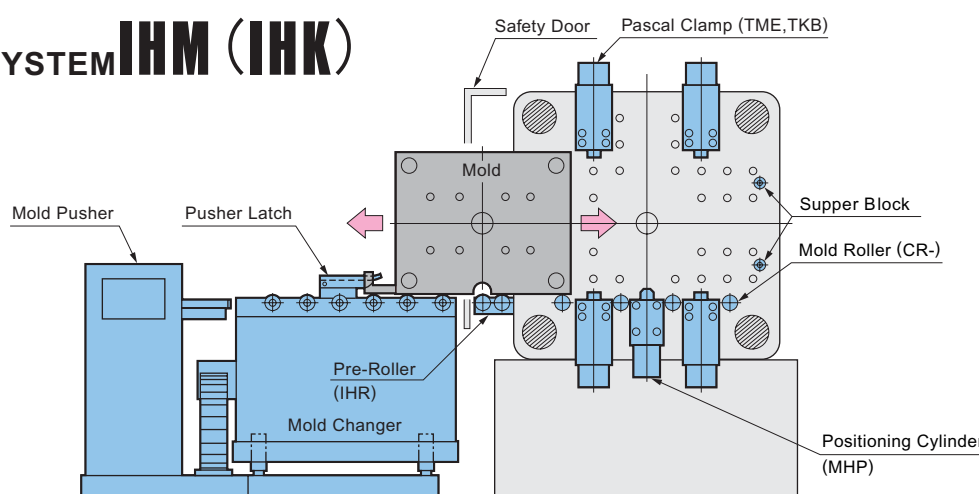

MODEL TME (small-medium size machine)

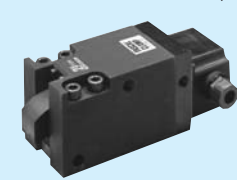

MODEL TKB (Large size machine)



Small-medium size Mold Change System

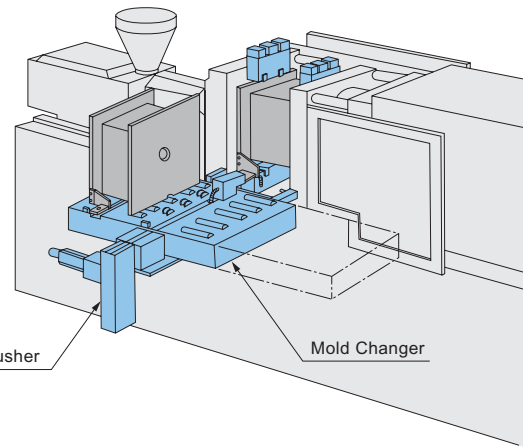

Medium-large size Mold Change System

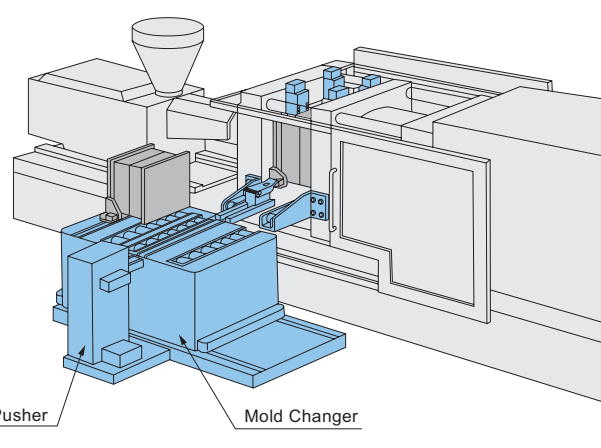

SELECTION OF CLAMP SYSTEM

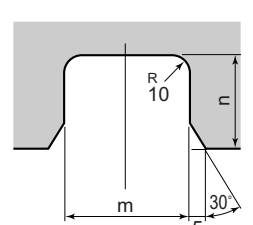
Injection Molding Machine		System IHM · IHK (TME · TKB clamp)		Mold Roller	Positioning Cylinder	U-cut dimensions		U-cut dimensions for positioning
Mold clamp Force (kN)	Mold opening Force (kN)	Model × No. Req.	Applicable Control Unit			m (mm)	n (mm)	
~ 500	39.2	TME1 × 8	HCFD-3CSS	CR- 20K	MHP1	30 ^{+0.1}	26	
~ 1000	98.0	TME2.5 × 8	HCFD-3CSS					
~ 2000	156	TME4 × 8	HCFD-3CSS	CR- 40K	MHP2	45 ^{+0.1}	32	
~ 3500	247	TME6 × 8	HCFD-3CSS					
~ 4500	392	TME10 × 8	HCFD-3CSS	CR- 60K	MHP3	60 ^{+0.1}	38	
~ 5500			HCFD-3CSS					
~ 6500	627(392)	TME16(TME10) × 8	HCE50-3LRLR	CR- 80K	MHP4	80 ^{+0.1}	38	
~ 8500	627	TME16(TKB16) × 8		CR- 100K				
~ 10000	980 (627)	TKB25 (TKB16) × 8		CR- 120K				
~ 13000	980	TKB25 × 8		CR- 160K				
~ 20000	1569	TKB40 × 8	HCE50-3LRLR	CR- 180K				
~ 25000								
~ 30000								

※Above mold opening forces are for reference. Inquire the clamp selection, when the actual mold opening force is greater than above value.

WIDE RANGE OF APPLICATIONS FROM PRECISE INJEC

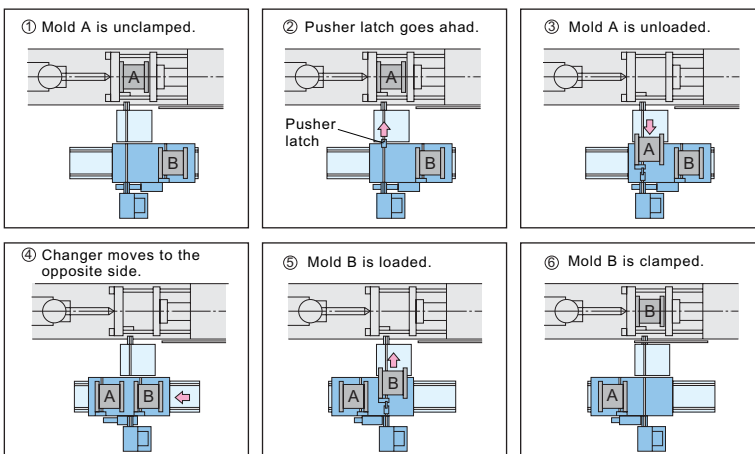
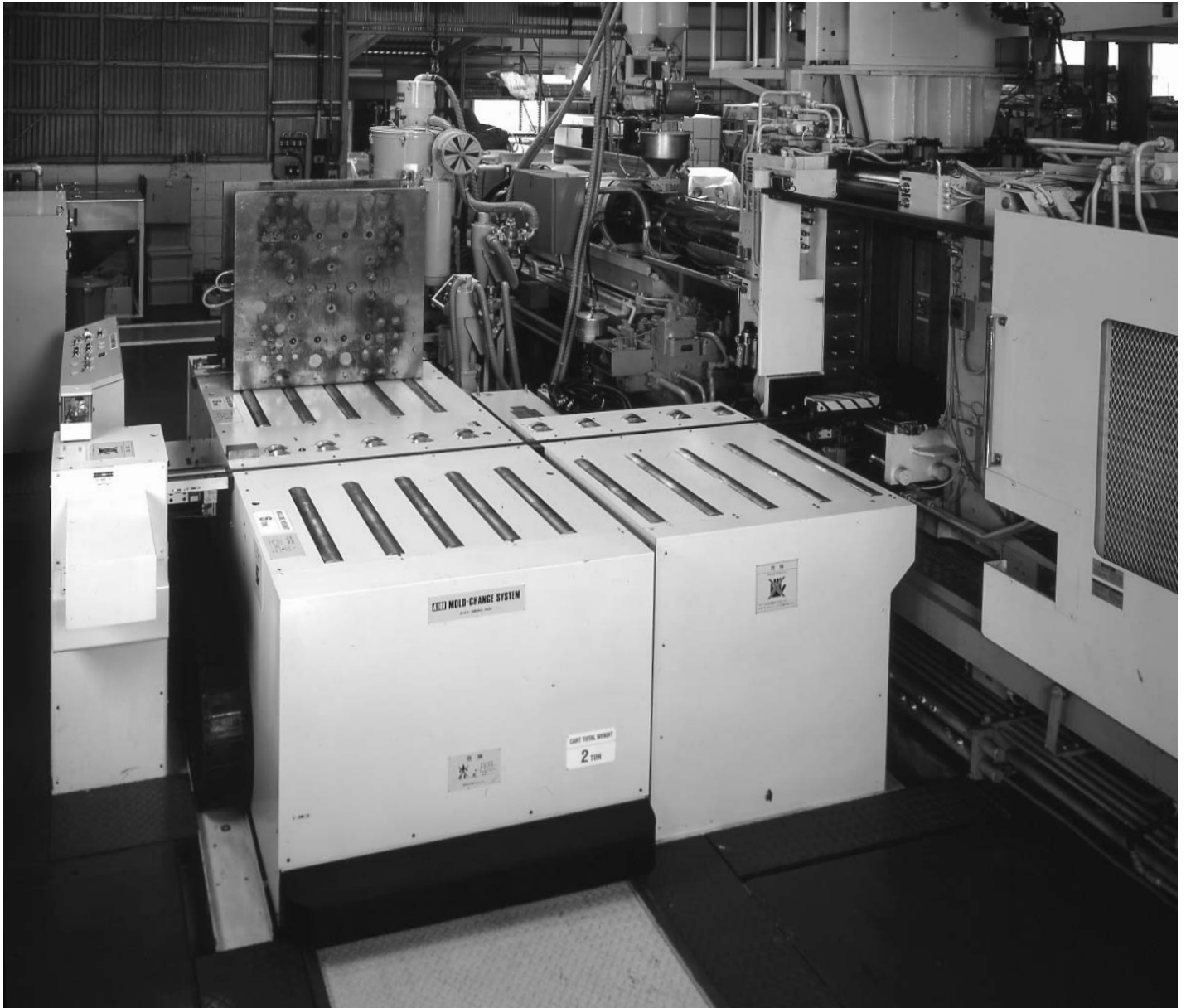

Introduction of **PASCAL** Horizontal Mold Change System leads to fully automated operation of injection molding plant.

PASCAL Mold Change System is equipped with a uniquely designed interlock system which allows unmanned operation.

INJECTION MOLDING TO LARGE AUTOMOBILE PARTS

TYPICAL SYSTEM LINE-UP

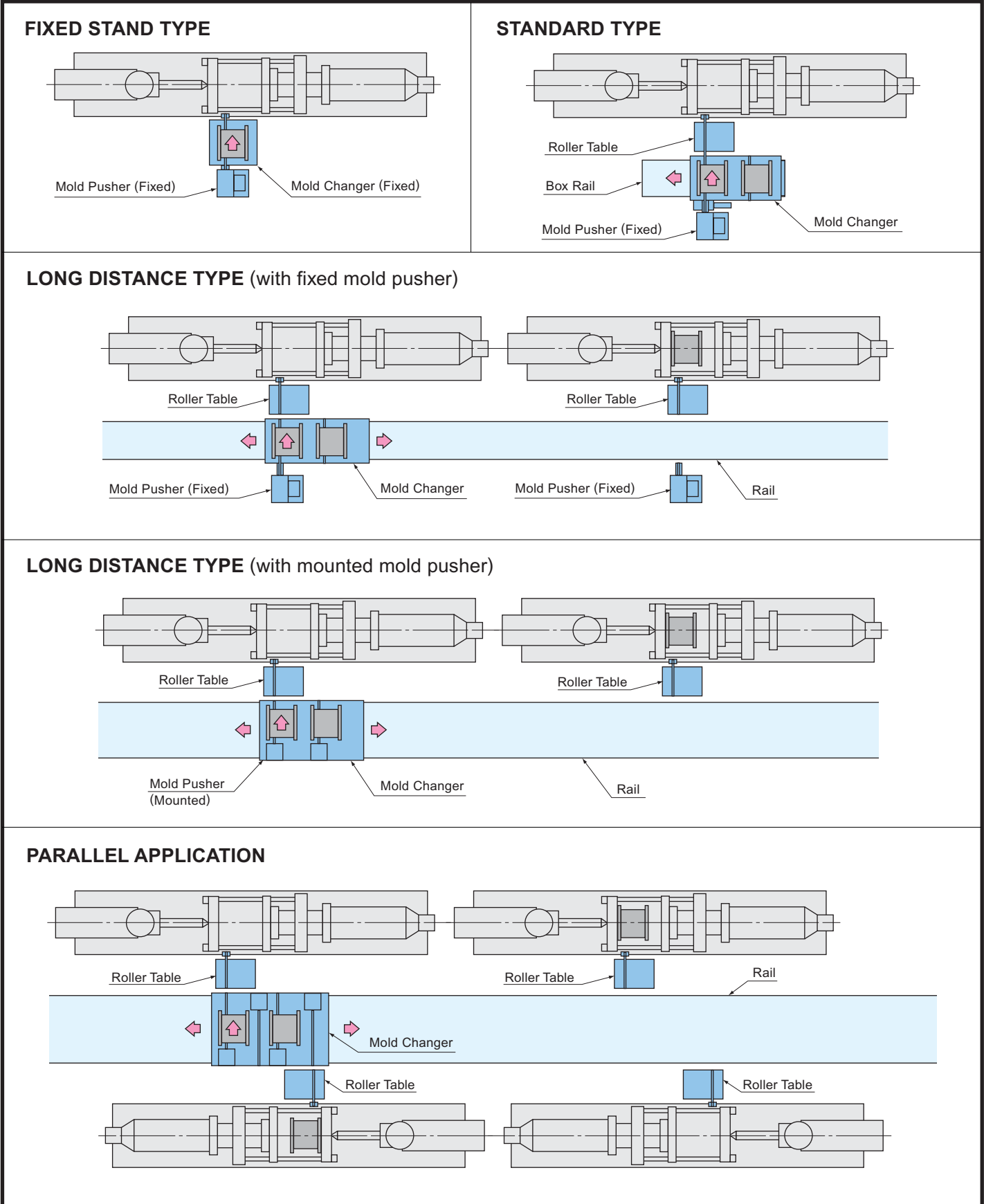

DATA FOR INQUIRY

PLEASE FILL IN THE BLANKS WHEN ORDERING

VERTICAL MOLD CHANGE SYSTEM IVM · IVK · IVY · IVX

HORIZONTAL MOLD CHANGE SYSTEM IHM · IHK

IV : VERTICAL
IH : HORIZONTAL

M : TME CLAMP Y : TYA CLAMP
K : TKB CLAMP X : TYC SLIDER

1. INJECTION MOLDING MACHINE MANUFACTURER / MODEL NEW EXISTING
NUMBER OF MACHINES _____
MOLD CLAMP FORCE _____
MOLD OPENING FORCE _____
PLATEN DETAIL CATALOG DRAWING OTHER

2. MOLD DIMENSIONS

DIMENSIONS	A	MAX.	~ MIN.
	B	MAX.	~ MIN.
	C		
	D	MAX.	~ MIN.
	E	MIN.	
	F		
WEIGHT	MAX.		
U-CUT FOR POSITIONING	<input type="checkbox"/> STANDARD <input type="checkbox"/> NON STANDARD		

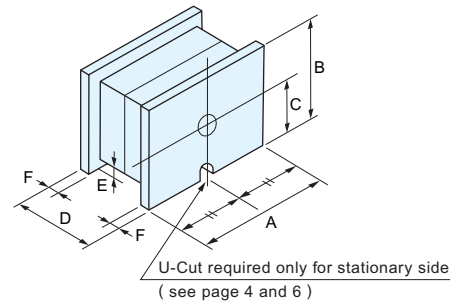

3. MOLD CHANGER

_____ TYPE

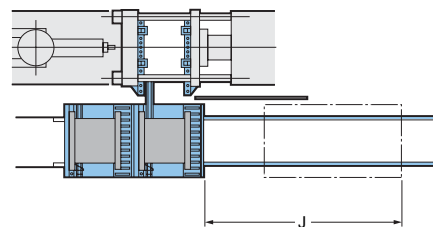
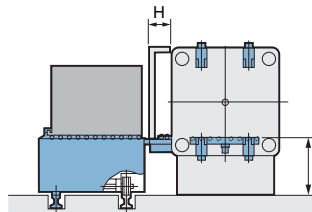

LOADING ELEVATION h = _____
SPACE BETWEEN SAFETY GATE TO PLATEN EDGE H = _____
TRAVELING DISTANCE J = _____
OPERATION MODE SEMI-AUTOMATIC FULL-AUTOMATIC
POWER SUPPLY CABLEVEYOR AUTO-REEL
VOLTAGE POWER V Hz
CONTROL ^{SOL.} L. S. V Hz
RESTRICTION TO INSTALLATION _____

4. REMARKS

AMBIENT TEMPERATURE NORMAL ELEVATED (° C)
OTHER _____

PASCAL® CLAMP SYSTEM

Pascal Quick Mold Change System consists of series of Pascal Clamps, proprietary designed true Non-Leak Valves, pressure relief valve to compensate thermal expansion of hydraulic fluids and air operated Pascal pump, all of which are specially developed for Quick Mold Change System of Injection Molding Machines.

VERTICAL MOLD CHANGE SYSTEM

Basic clamping pattern with the centering block and guide blocks.

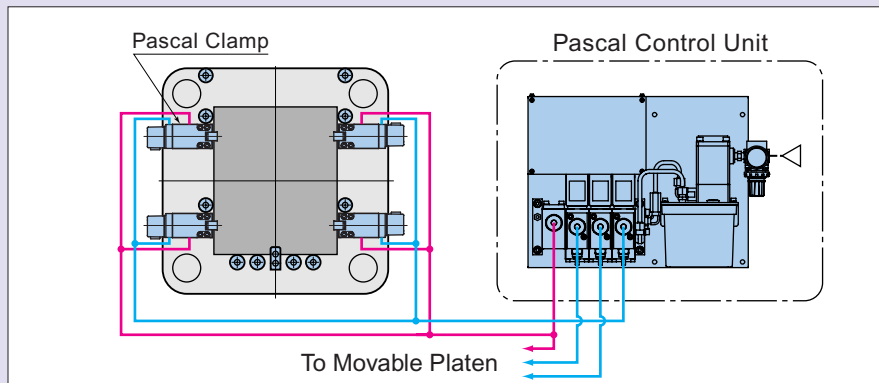

HORIZONTAL MOLD CHANGE SYSTEM

Basic clamping pattern with the positioning cylinder and rollers in/out the molding machine for safety.

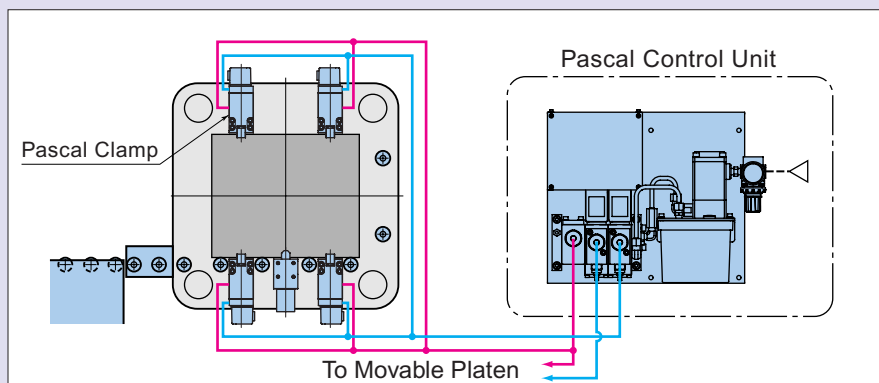

Model TME is a retractable lever type clamp and ensures sufficient mold holding force by a heavy duty spring even at the oil pressure failure.



FIXED

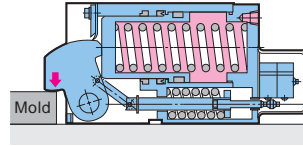

UNFIXED

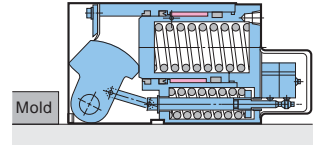

CIRCUIT DIAGRAM

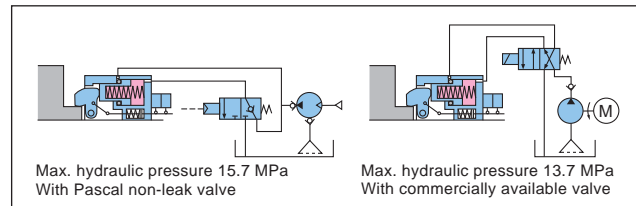

SPECIFICATIONS (TME size L- h dimension L,R : direction of conduit port)

MODEL		TME1L	TME2.5L	TME4L	TME6L	TME10L	TME16L
Fixing Force (kN)	At Max. hydraulic pressure	9.8	24.5	39.2	61.7	98	157
Holding Force (kN)	At Max. hydraulic pressure	9.8	24.5	39.2	61.7	98	157
	At no hydraulic pressure(0MPa)	0.49	0.98	1.56	2.45	3.92	5.88
Full Stroke : X	(mm)	3.5	4	4	4	4.5	4.5
Fixing Stroke : Y	(mm)	2	2	2	2	2	2
Safety Stroke : Z	(mm)	1.5	2	2	2	2.5	2.5
Cylinder Capacity	Fixed (cm ³)	15	41	92	163	298	470
	Unfixed (cm ³)	6	11	28	48	87	143
Weight	(kg)	3	6	9	15.5	30	55

■ Proof pressure : 20.5MPa ■ Working temperature range : 0~70°C (5~120°C by heat proof type)
 ※The hydraulic pressure required to unclamp is 2.9 MPa.

DIMENSIONS TME2.5~16L-h

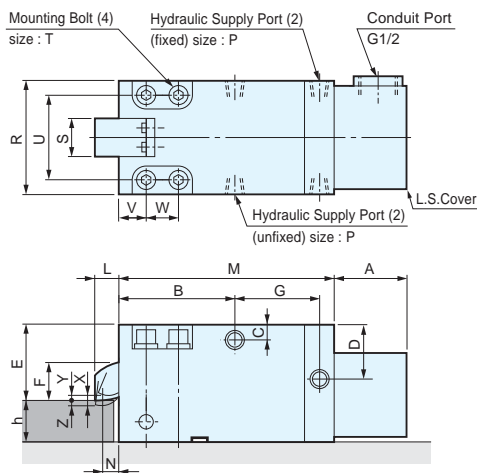

TME1L-hR

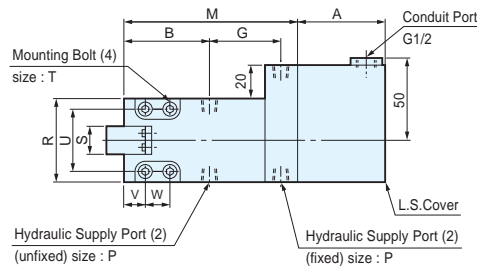

TME1L-hL

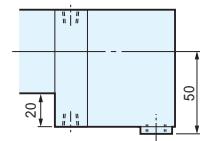

(mm)

MODEL	E	F	G	L	M	N	R	S	U	V	W	T	h (※)	A	B	C	D	P
TME1 L	42	21	56	11	121.5	9	52	18	38	12	18	M 8	MIN.20	59.5	55.5	11	23.5	Rc1/8
TME2.5L	56	30	65.5	16	149.5	12	78	27	58	17	22	M10	MIN.30 (25)	59.5	74	15	31	Rc1/4
TME4 L	76	39	80	19	180	14.5	88	35	68	20	26	M12	MIN.30 (25)	59.5	89	20	39	Rc1/4
TME6 L	90	43	86	21	197	15	108	45	84	22	30	M14	MIN.35 (30)	59.5	99	24	48	Rc1/4
TME10 L	112	57	100	25	238.5	19	135	55	106	30	36	M18	MIN.40 (35)	64	121	30.5	61	Rc3/8
TME16 L	137	78	108.5	32	285	20	182	72	135	40	50	M24	MIN.40	68.5	156.5	38.5	62	Rc3/8

※Dimensions h in parentheses are special specifications.

Model TKB is a retractable lever type clamp. The unique wedge construction ensures a strong holding force, even with oil pressure failure.

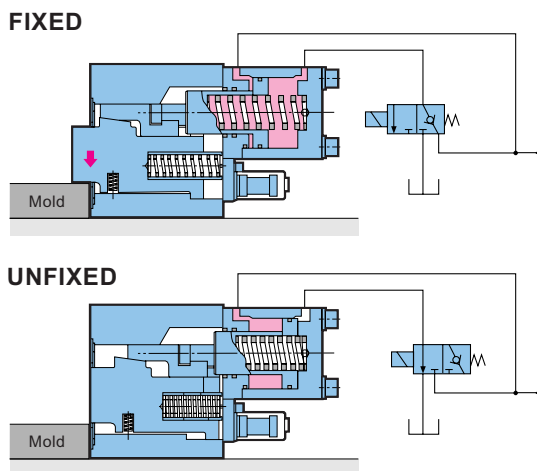

SPECIFICATIONS (TKB size L- h dimension)

MODEL		TKB16	TKB25	TKB40	TKB50
Fixing Force (kN)	At hydraulic pressure 13.7MPa	49.0	78.4	137.2	176.5
Holding Force (kN)	At hydraulic pressure 13.7MPa	157	245	392	490
	At no hydraulic pressure (0MPa)	19.6	29.4	49.0	88.2
Full Stroke : X	(mm)	4.5	4.5	5.5	5.5
Fixing Stroke : Y	(mm)	2	2	2.5	2.5
Safety Stroke : Z	(mm)	2.5	2.5	3	3
Cylinder Capacity	Fixed (cm ³)	284	460	859	1428
	Unfixed (cm ³)	173	277	507	931
Weight	(kg)	38	67	130	250

■ Proof pressure : 20.5MPa ■ Working temperature range : 0~80°C

DIMENSIONS

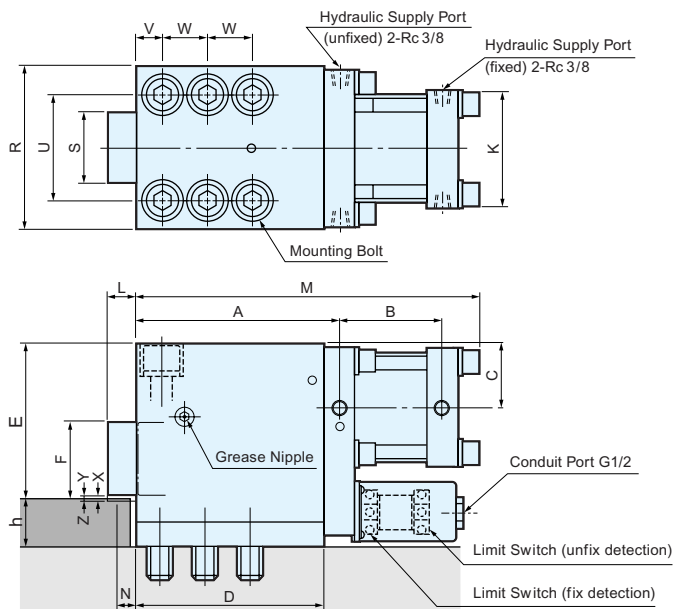

(mm)

MODEL	E	F	L	M	N	R	S	U	V	W	K	T	h	A	B	C	D
TKB16	140	75	32.9	310	20	145	65	98	22	39	105	M20	MIN.40	180.5	99	58	165.5
TKB25	170	82	32.7	368.5	20	175	76	118	27	49	128	M24	MIN.50	221	110.5	69	204.5
TKB40	200	99	38	434.1	25	215	90	145	32	60	155	M30	MIN.50	262	129	81	242.5
TKB50	275	135	43.2	552.9	30	270	115	190	40	80	197	M39	MIN.50	325	179	103.5	300

Model TYA is a lever clamp designed to be inserted to T-slot of platens. It has a large fixing force with shock-proof rigidity as well as long fixing stroke.



STRUCTURE

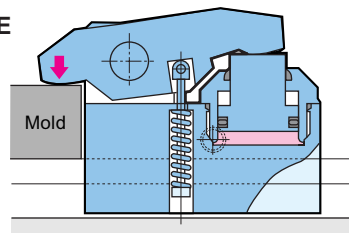

APPLICATION EXAMPLE

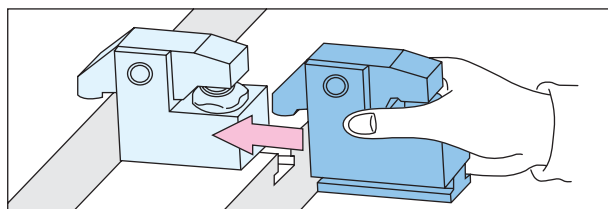

SPECIFICATIONS (TYA)

MODEL	TYA1	TYA2	TYA4	TYA6	TYA10	TYA16	TYA25
Fixing Force At hydraulic pressure 24.5MPa (kN)	9.8	19.6	39.2	61.7	98	157	245
Full Stroke : X (mm)	6	7	7	8	8	8	8
Fixing Stroke : Y (mm)	3	4	4	5	5	5	5
Safety Stroke : Z (mm)	3	3	3	3	3	3	3
Cylinder Capacity At Full Stroke (cm ³)	2.4	6.3	13.2	22.3	37	61	93
Weight (kg)	1	3	4.5	9	15	25	35

■ Proof pressure : 36.7MPa ■ Working temperature range : 0~70°C (5~120°C by heat proof type)

※ Fixing stroke and safety stroke shown above are the standard. Special type is available at option.

※ Weight varies according to the dimension of T-leg as well as h.

DIMENSIONS

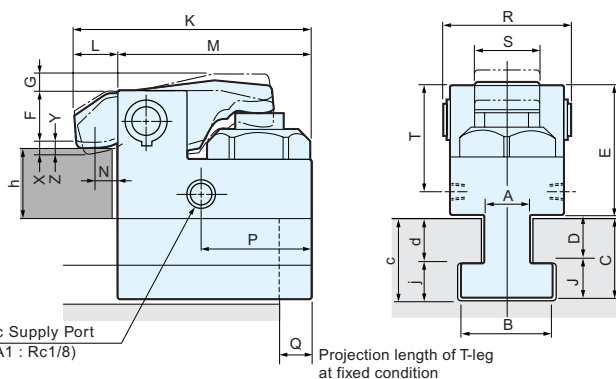

Hydraulic Supply Port
(only TYA1 : Rc1/8)

Projection length of T-leg
at fixed condition

Specify t-slot dimensions (a,b,c,d,j) and workpiece height (h) when ordering.

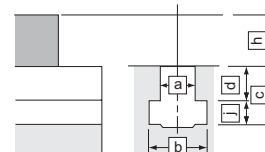

● About "d" dimension

1. When in stalling on existing machine, specify in 0.1 mm resolution for us to design.

2. When installing on new machine, you need to machine the platen with the machining tolerance of ± 0.2 mm.

● Dimensions A,B,C,D,J shall be determined according to T-slot dimensions.

● When newly machining T-slot, it is recommended to apply the dimensions specified on page 4.

(mm)

MODEL	F ※1	MAX.G	K	L	M	N	P	MAX.Q ※3	R	S	T	MIN.E	MIN.J	h=MIN-MAX. ※2	MIN.a
TYA1	16.5 (25 ≤ h)	6	73	15	58	10	31	18	43	20	34.5	44.5	7	15~50	10
	21.5 (20 ≤ h (25))														
	26.5 (16 ≤ h (20))														
TYA2	17.5 (32.5 ≤ h)	10	101	18	83	12.5	41	22	58	28	43	54	8.5	22.5~50	12.5
	22.5 (27.5 ≤ h (32.5))														
	27.5 (22.5 ≤ h (27.5))														
TYA4	27.5 (38 ≤ h)	10	143	23	120	16	55	32	73	40	57.5	69.5	10.5	28~50	15
	32.5 (33 ≤ h (38))														
	37.5 (28 ≤ h (33))														
TYA6	29.5 (47 ≤ h)	10	163	30	133	20	51	36	93	50	68.5	81.5	14	27~60	19
	39.5 (37 ≤ h (47))														
	49.5 (27 ≤ h (37))														
TYA10	45 (57 ≤ h)	11	195	30	165	20	62	45	104	55	97	107	16	37~70	23
	55 (47 ≤ h (57))														
	65 (37 ≤ h (47))														
TYA16	60 (67 ≤ h)	12	230	30	200	20	80	55	125	60	120	132	19	47~80	27
	70 (57 ≤ h (67))														
	80 (47 ≤ h (57))														
TYA25	76 (87 ≤ h)	13	270	30	240	20	90	69	155	72	156	168	22	67~80	32
	86 (77 ≤ h (87))														
	96 (67 ≤ h (77))														

※ F will be decided according to the dimension of h (mold thickness). If h dimension is shorter than the minimum figure of F, the product will be treated as special type.

※ If h dimension is larger than the maximum figure, the product will be also treated as special type.

※ There are cases when the projection length of T-leg exceeding the Max. Q figure may be used according to the T-slot dimensions. In such case, ask us for details.

Model TYC-R is equipped with an automatic slider on top of model TYA. Clamp and unclamp can be very swiftly done in order to minimize the operation time.



FIXED

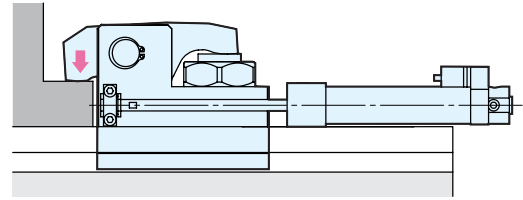

UNFIXED

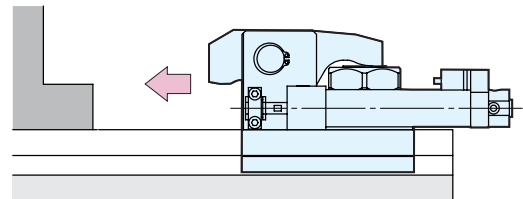

SPECIFICATIONS (TYC [size] R- [Proximity switch model] — [sliding dimension])

MODEL	TYC2R	TYC4R	TYC6R	TYC10R	TYC16R	TYC25R
Fixing Force At hydraulic pressure 24.5MPa (kN)	19.6	39.2	61.7	98	157	245
Sliding Stroke (mm)	MAX.150		MAX.200	MAX.300		
Slider Driving Air Pressure (MPa)	0.39~0.54					
Clamp Sliding Speed (mm/s)	30~80 (Adjusted by speed controller)					
Weight (kg)	3.5	5	10	16	26	38

■Proof pressure : 36.7MPa ■Working temperature range : 0~70°C (5~120°C by heat proof type)

※Weight varies according to the dimension of T-leg as well as h.

DIMENSIONS

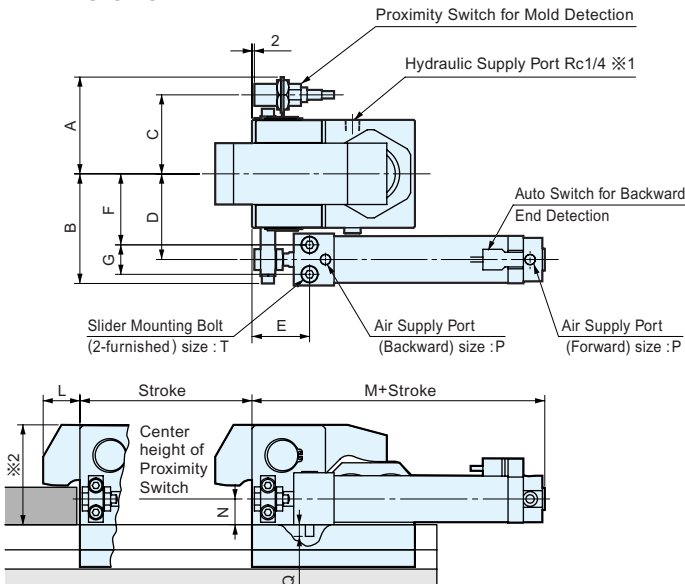

PROXIMITY SWITCH SPECIFICATIONS (OMRON)

Symbol of proximity switch model	Blank (not specified)	E1	E2
Switch Model	2-Wire DC※ E2E-X7D1-N	3-Wire DC E2E-X5E1	2-Wire AC E2E-X5Y1
Supply Voltage	DC10~30V	DC10~40V	AC20~264V
Leakage Current	Max.0.8mA		Max.1.7mA
Current Consumption		Max.13mA	
Control Output (Switching Capacity)	3~100mA	200mA	5~300mA

Insulation vinyl cable length : 5m (Oil proof type, 0.5mm²)

※Unless specified, 2-wire DC type shall be delivered.

AUTO SWITCH SPECIFICATION (SMC)

Switch Model	D-B54L		
Load Voltage	DC24V	AC100V	AC200V
Range of Load Current	5~50 mA	5~25 mA	5~12.5 mA

Insulation capture cable length : 3m (Oil proof type, 0.3mm²)

(mm)

MODEL	A	B	C	D	E	F	G	L	M	N	T	Q	P
TYC 2R	61.5	64.6	47	48.5	42.5	39.5	18	18	108.5	15	M5×35	9.5	Rc1/8
TYC 4R	69	72.1	54.5	56	42.5	47	18	23	108.5	15	M5×35	9.5	Rc1/8
TYC 6R	79	89.5	64.5	70	47	58	24	30	119	21	M8×45	9.6	Rc1/8
TYC 10R	89	109	74	81	57	65	32	30	137	26	M10×55	12.6	Rc1/8
TYC 16R	99	119	84	91	57	75	32	30	137	26	M10×55	12.6	Rc1/8
TYC 25R	113.5	153	98.5	116	71	95.5	41	30	164	32	M12×70	17	Rc1/4

※ 1. The position of hydraulic port is subject to change. It should be confirmed on the approval drawing.

※ 2. For the detailed dimensions of clamp body, refer to the model TYA on previous page. Note that the height E may become different from model TYA's. You are requested to confirm on the approval drawing.

Model VSE is a valve unit containing the modules such as Pascal valve with special non-leak function, pressure relief valve and pressure switch, etc. Model VSE is particularly designed with its high reliability for the application in injection molding machines.



SPECIFICATIONS (VSE ☒ -3 [Circuit symbol])

MODEL	VSE ☒ -3CSSK	
Hydraulic pressure (from injection molding machines)	13.7(15.7) MPa	
Set pressure of pressure switch (increase)	8.8 MPa	
Maximum working pressure	20.6 MPa (at pilot air pressure 0.49MPa)	
Orifice area	P → A	12.6 mm ²
	A → R	19.4 mm ²

- Fluid used : ISO-VG32 equivalent mineral oil
- Working temperature range : 0~50°C
- When applying a Pascal pump as power source, model name becomes VS ☒ -3 [Circuit symbol]
- 1.57 MPa is when the clamp model TME is used.

☒ Electrical power voltage shall be specified as per the following classifications.

A	AC100V
B	AC200V
C	AC110V
D	DC 24V
E	AC220V

DIMENSIONS

MODEL	A (mm)	Weight (kg)
VSE ☒ -3CSK	200	15
-3CSSK	250	19

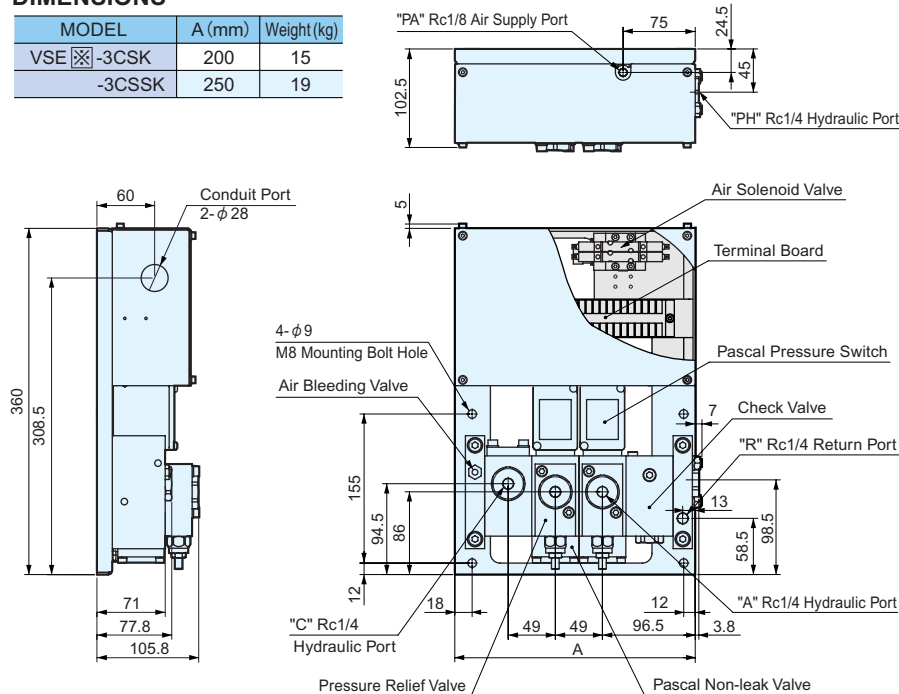

CIRCUIT DIAGRAM

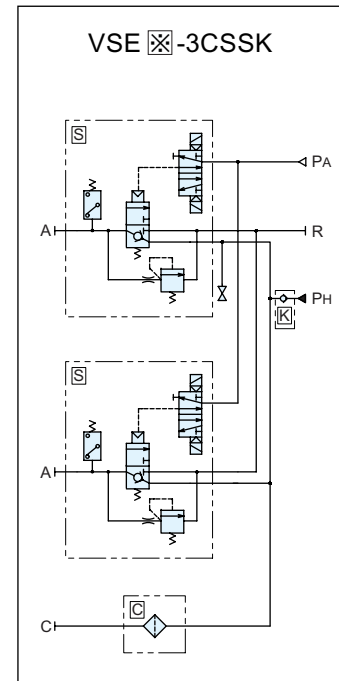

Hydraulic circuit specifications		Symbol
C port with inline filter		C
C port with pressure gauge for incoming pressure		Q
Pressure gauge for incoming pressure		E
C port with pressure switch for incoming pressure		H
Clamp	Single solenoid	D
	Double solenoid	L
	D circuit with relief valve for excessive high pressure	X
	L circuit with relief valve for excessive high pressure	S

For the detail of hydraulic circuit and options, ask us separately.

Pascal pump and non leak valve are combined into an unit for the molding machine with no hydraulic power supply. Power source is the factory air.



SPECIFICATIONS (HCF [Symbol] - [Pump] [Circuit symbol] - [Option symbol])

MODEL	HCF [Symbol] -2SSS	HCF [Symbol] -3CSS
Pascal Pump model	HPH6308	HPH6310
Discharge pressure	24.5 MPa	15.7 MPa
Driving air pressure	0.47 MPa	0.47 MPa
Discharge volume at no load	1.4 L/min.	2.1 L/min.
Pressure switch set pressure (increase)	14.7 MPa	8.8 MPa
Orifice area	P→A	12.6 mm ²
	A→R	29.4 mm ²
Tank volume	HIGH-LEVEL 1.5 L / LOW-LEVEL 0.4 L	
Clamp application(example)	TYA 10 × 8 units	TME 2.5 × 8 units

- Fluid used : ISO-VG32 equivalent mineral oil
- Working temperature range : 5~50°C
- Air consumption rate : Max. 0.4 Nm³/min

[Symbol] Electrical power voltage shall be specified as per the following classifications.

A	AC100V
B	AC200V
C	AC110V
D	DC 24V
E	AC220V

DIMENSIONS

Number of hydraulic circuit	A (mm)	Weight (kg)
1	330	14
2	365	18
3	415	22
4	465	26

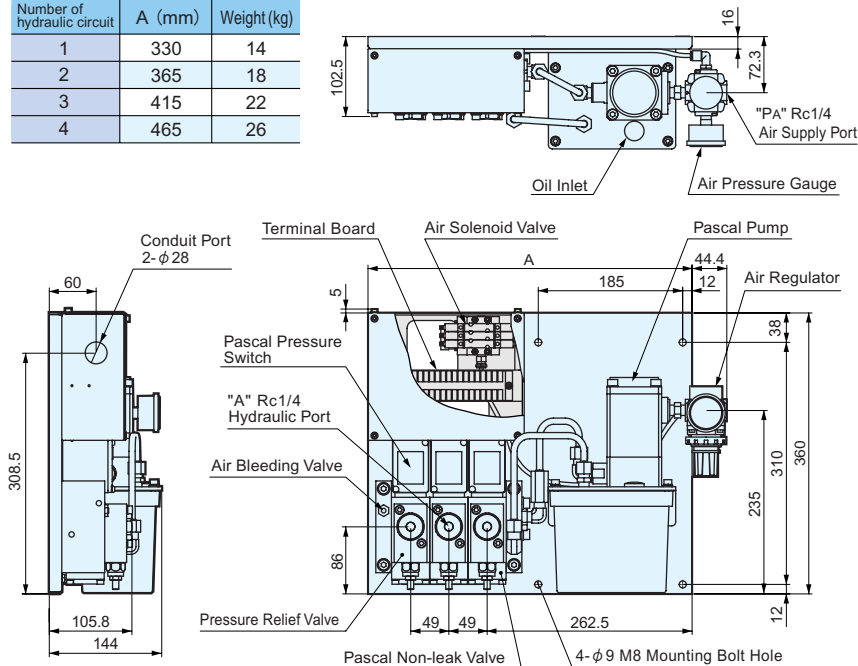

CIRCUIT DIAGRAM

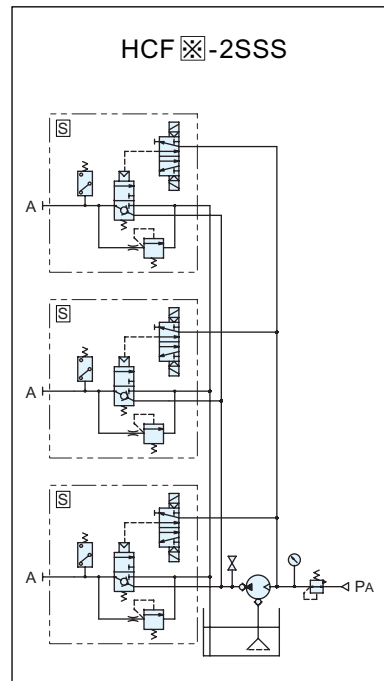

Hydraulic circuit specifications		Symbol
C port with inline filter		C
C port with pressure gauge for incoming pressure		Q
Pressure gauge for incoming pressure		E
C port with pressure switch for incoming pressure		H
Clamp	Single solenoid	D
	Double solenoid	L
	D circuit with relief valve for excessive high pressure	X
	L circuit with relief valve for excessive high pressure	S

Option	Symbol
With filter regulator	F

For the detail of hydraulic circuit and options, ask us separately.

Pascal pump, non-leak valve, digital pressure gauge and relief valve are compactly integrated into this unit. Suitable for a middle or large molding machine. Types of stand other than shown below are available on request.



SPECIFICATIONS (HCM-D - Pump - Circuit symbol - Option symbol)

MODEL	HCMD-2 SSS	HCMD-22 SSSS	HCMD-3 CSS	HCMD-33 CSS
Pascal Pump model	HPH6308(Single)	HPH6308(Twin)	HPH6310(Single)	HPH6310(Twin)
Discharge pressure	24.5 MPa		15.7 MPa	
Driving air pressure	0.47 MPa		0.47 MPa	
Discharge volume at no load	1.4 L / min.	2.8 L / min.	2.1 L / min.	4.2 L / min.
Tank capacity	HI-LEVEL 5.7 L / LOW-LEVEL 1.6 L			
Clamp applications (example)	TYA16 × 8 units TYC16 × 8 units	TYA25 × 8 units TYC25 × 8 units	TME4 × 8 units	TME 6 × 8 units TME10 × 8 units

- Fluid used : ISO-VG32 equivalent mineral oil ■ Working temperature range : 5~50°C
- Air consumption rate : Max. 0.4 Nm³/min.(Single pump) MAX.0.8Nm³/min.(Twin pump)
- Electric power voltage : DC 24 V

DIMENSIONS

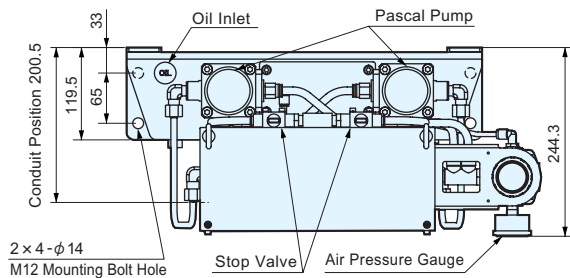

STAND (OPTION)

Model : ZPS-S4

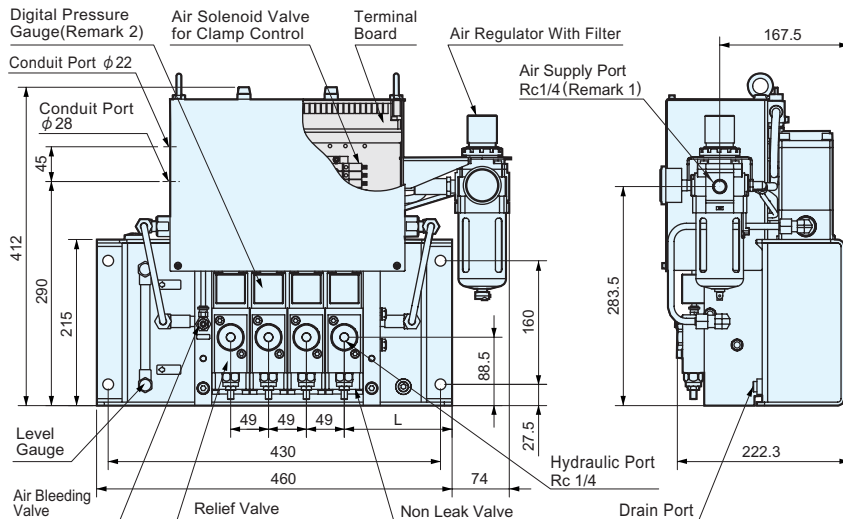
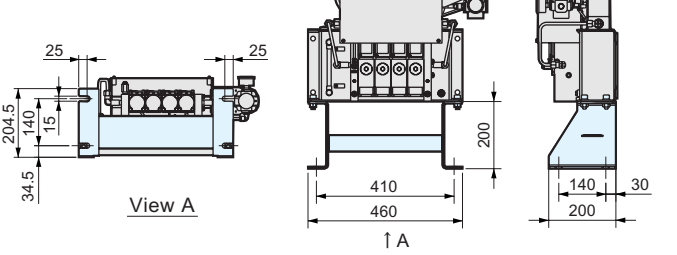

Number of hydraulic circuit	L (mm)	Weight (kg)※
1	213	28
2	188.5	32
3	164	35
4	139.5	39

※ : For the case of single pump.
3kg to be added in case of twin pump.

Remark 1 : Piping diameter for single pump (Rc3/8 for twin pump)

Remark 2 : Digital pressure gauge outputs 2 kinds of signals such as pressure increase and abnormal high pressure detection.

Drawing shown here is for 1 to 4 hydraulic circuits. For 5 or more circuits application, ask us for details.

Hydraulic circuit specifications		Symbol
C port with inline filter		C
C port with pressure gauge for incoming pressure		Q
Pressure gauge for incoming pressure		E
C port with pressure switch for incoming pressure		H
Clamp	Single solenoid	D
	Double solenoid	L
	D circuit with relief valve for excessive high pressure	X
	L circuit with relief valve for excessive high pressure	S

Option	Symbol
Low oil level detection switch	L
Air solenoid valve (2 sets) for slider and mold positioning pin at platen	T

For the detail of hydraulic circuit and options, ask us separately.

User friendly control panels with compact body and clear indication. Model EST is the operation panel, and model ECT is the control box. Brackets other than shown below are available on request.

model **EST-AE-1** (Operation Panel : L Bracket Type)

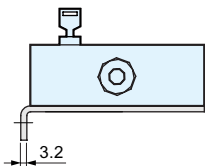
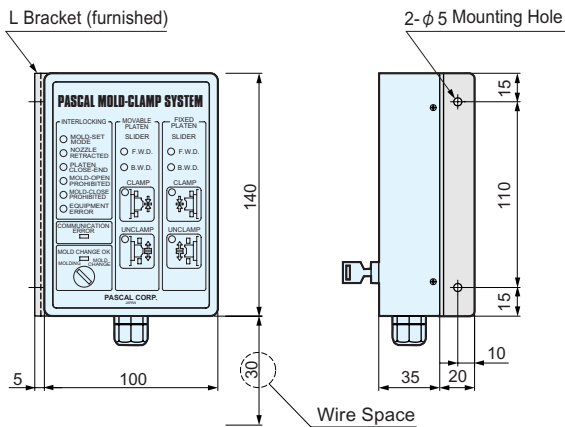
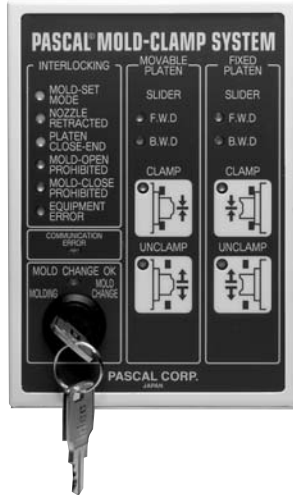

model **ECT-AE-1** (Control Box : L Bracket Type)

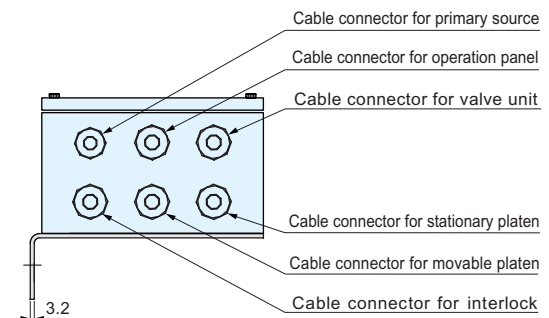
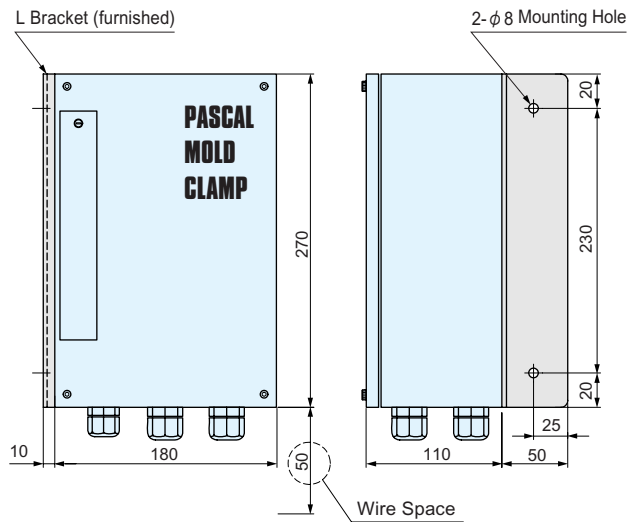
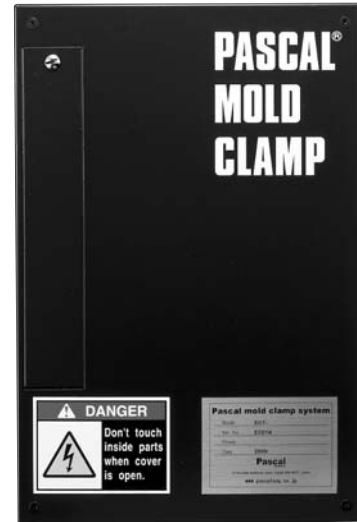

Pascal

corporation

10 Konoike-kaidosita, Itami,
Hyogo 664-8502, Japan
TEL.(072)777-3333 FAX.(072)777-3520



CERTIFICATE OF APPROVAL ISO9001