

air
operated

REV.3

PASCAL MOLD-CLAMP SYSTEM

Air Operated Clamp Series

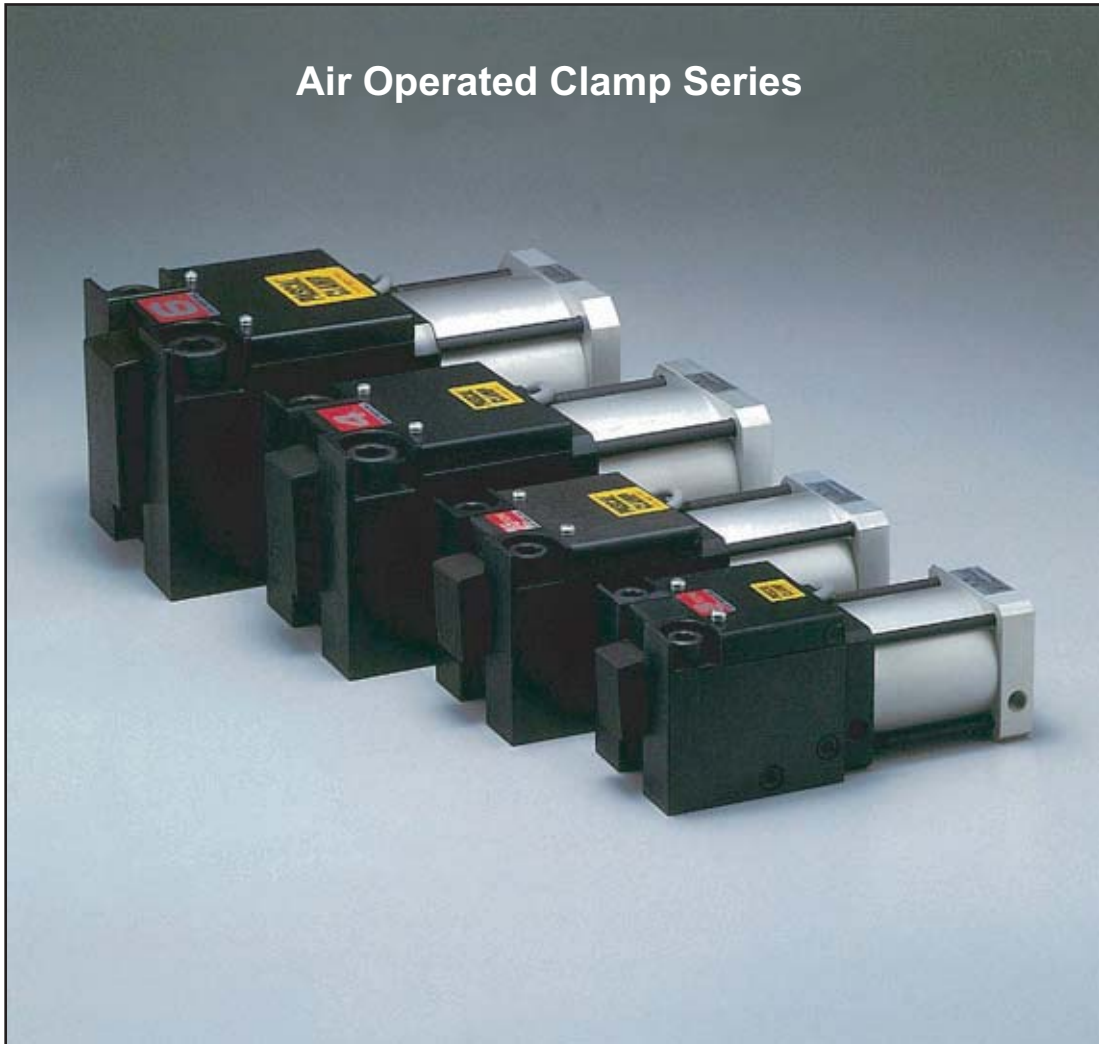

Pascal
corporation

www.pascaleng.co.jp

air operated clamps

model **TL** series



PASCAL TL series is an air-operated mold clamp. The unique wedge structure ensures a clamping force as strong as hydraulic.

■ No hydraulic power required

- No oil leakage, thus no chance for molded product to get oil adherence.
- Best suitable for manufacturing line of medical, electronic or food-related products where a sheer clean environment is required.
- Facile installation to a recent-popular machine such as electric type injection molding machine that has no hydraulic power source.
- No particular hydraulic piping skills required for installation.

■ Features

Safe and reliable clamp. Powerful spring and unique wedge structure keeps the mold holding force even at no air supply condition. (Even in zero air pressure condition, about 40% of the rated mold holding force at 0.49 MPa of air pressure can be maintained, and the fixing force becomes about 30% of the rated holding force.)

Mold holding force (at air pressure 0.49 MPa)

9.8, 15.6, 24.5, 39.2, 61.7, 98, 157, 245 kN

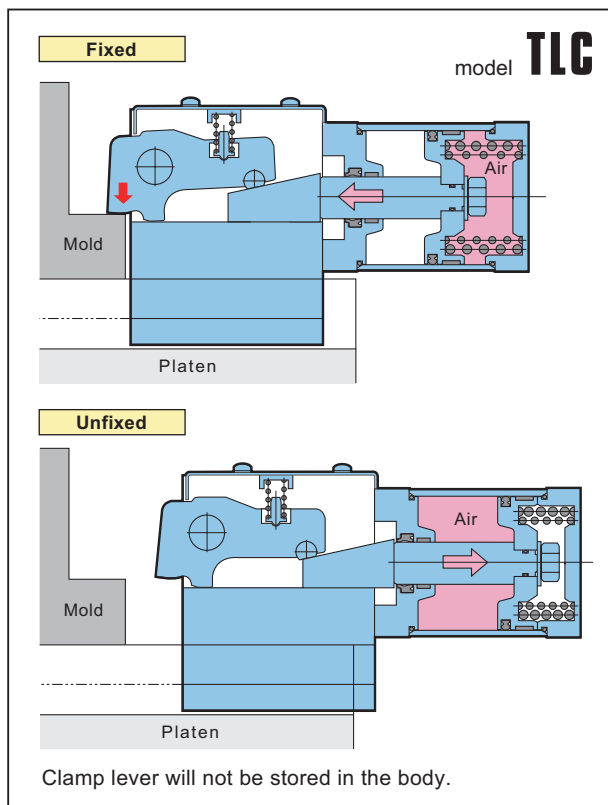
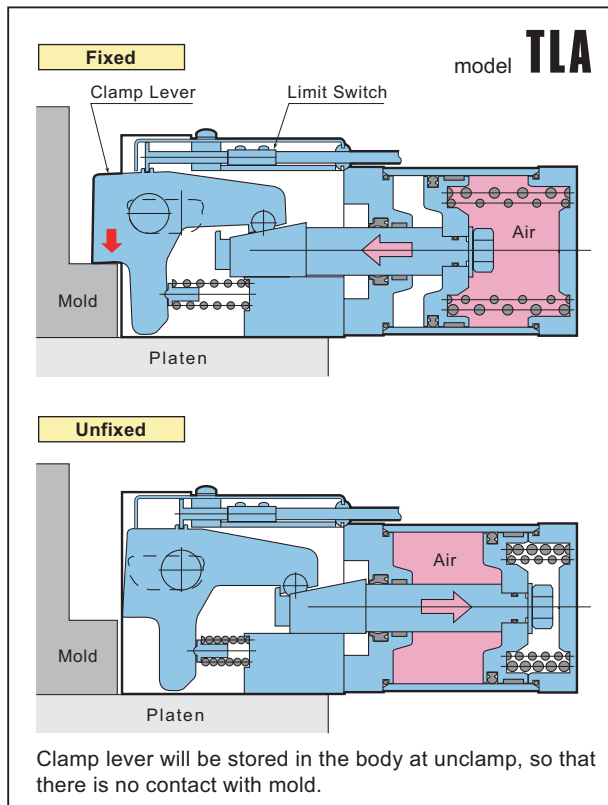

PASCAL MOLD-CLAMP SYSTEM

BOLT FIX CLAMP

model **TLA**



page 4

When the width of mold plates and the thickness of clamping portion can be unified, model TLA is applicable. Guide block and positioning block are available (made-to-order) for easy mold loading. Ask us for details.

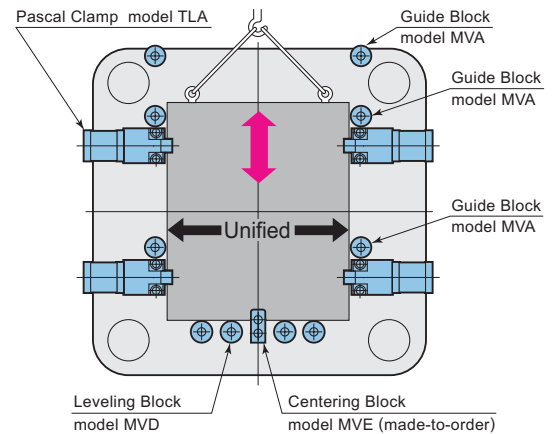

MANUAL SLIDE CLAMP

model **TLC**



page 5

When the width of mold plates can not be unified, model TLC is applicable. You just need to unify the thickness of clamping portion of mold plate, and prepare a T-slot on the mold plate or insert a T-slotted plate.

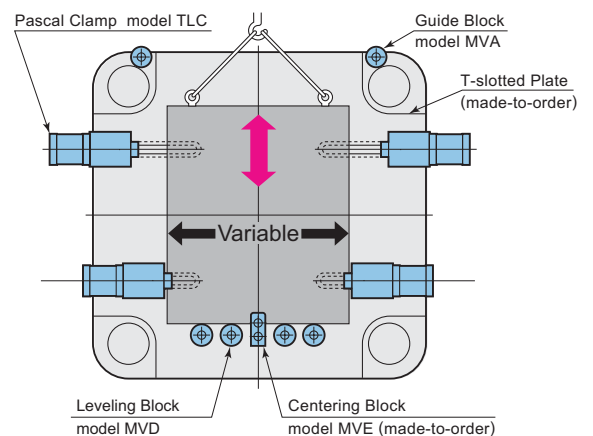

AUTO SLIDE CLAMP

model **TLC-RE**

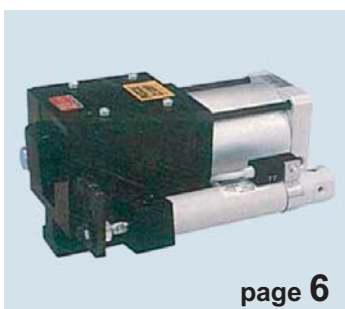

page 6

Air cylinder is added to model TLC for auto slide function. Clamp and unclamp can be done by a switch action. You just need to unify the thickness of clamping portion of mold plate, and prepare a T-slot on the mold plate or insert a T-slotted plate.

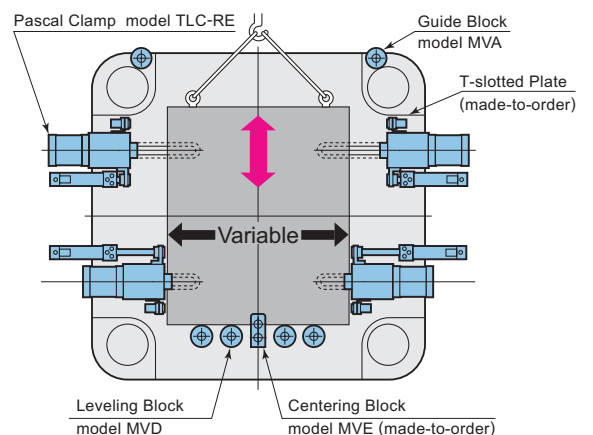

- When inserting a T-slotted plate on the platen, there must be some margin of daylight as well as a modification of injection unit and nozzle touch portion.
- Above applications are for vertical loading with crane. If you need a horizontal loading with mold change cart, ask us separately.

System Selection

■ Circuit Example of clamp system

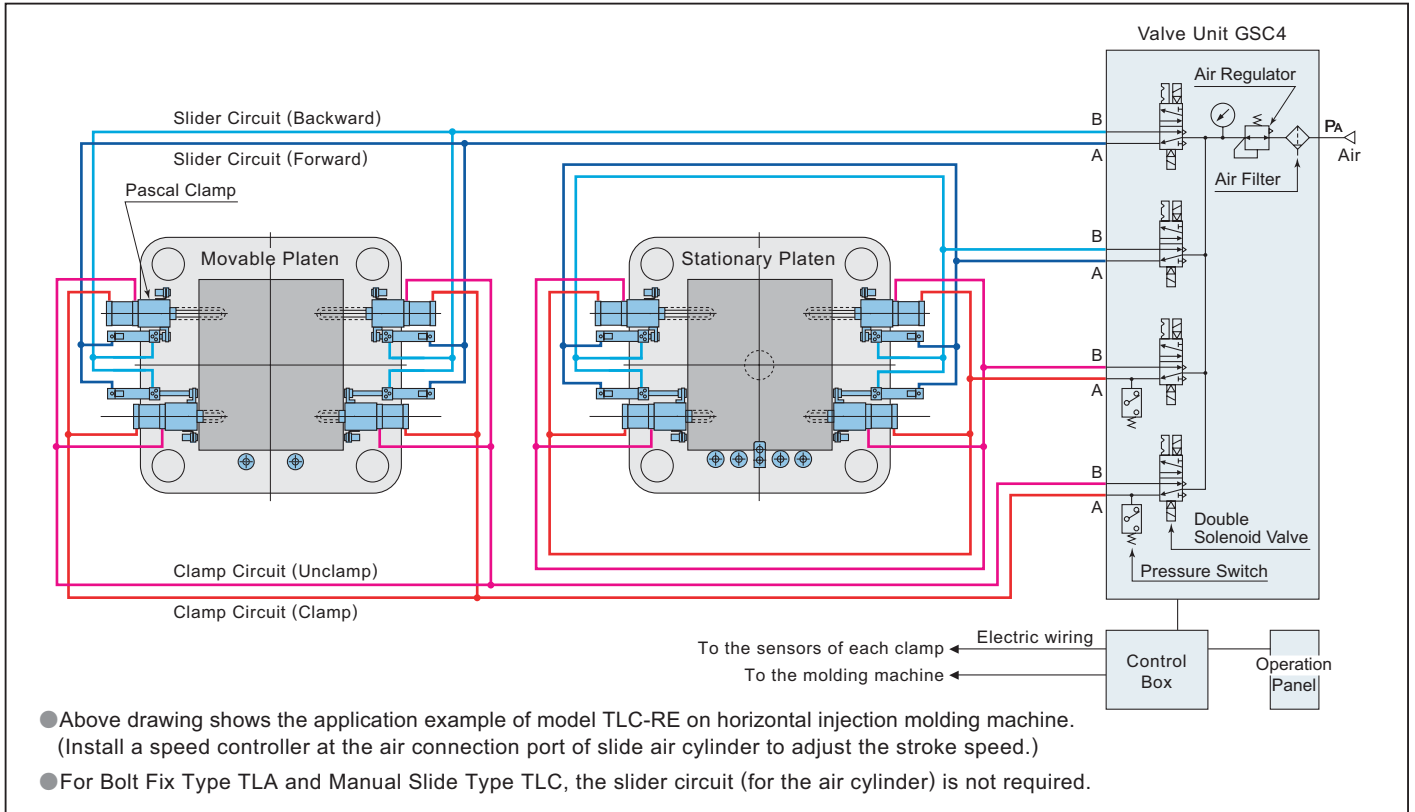

■ Clamp Selection Table

Injection Molding Machine		BOLT FIX CLAMP (Stationary/Movable 4 units each)		MANUAL SLIDE CLAMP (Stationary/Movable 4 units each)		AUTO SLIDE CLAMP (Stationary/Movable 4 units each)	
Mold Clamping Force (kN)	Mold Opening Force (kN)※	Clamp Model	Valve Unit	Clamp Model	Valve Unit	Clamp Model	Valve Unit
~500	39	TLA 1	GSC2-1	TLC 1	GSC2-1	TLC 1RE	GSC4-1
~800	62	TLA1.6		TLC 1.6		TLC 1.6RE	
~1250	98	TLA2.5		TLC 2.5		TLC 2.5RE	
~2000	156	TLA 4		TLC 4		TLC 4RE	
~3500	246	TLA 6	GSC3-2	TLC 6	GSC3-2	TLC 6RE	GSC4-2
~5500	392	TLA 10		TLC 10		TLC 10RE	
~6500	628	TLA 16					
~8500	980	TLA 25					

※: Mold opening forces are to be used for clamp selection. If mold opening force is larger than above, ask us separately.

■ Dimension of Standard T slot and U-cut for mold positioning

- When newly machining T-Slot for manual or auto slide clamp
- When positioning a mold by using a U-cut

➔

**Should be machined
with below dimensions**

Injection Molding Machine	Clamp Model			Recommended Dimension of T-Slot				Dimension of U-cut for centering		T-Slot	U-cut for centering at mold Not required when positioned with locate ring
	BOLT FIX CLAMP	MANUAL SLIDE CLAMP	AUTO SLIDE CLAMP	a (mm)	b (mm)	d (mm)	j (mm)	m (mm)	n (mm)		
~500	TLA 1	TLC 1	TLC 1RE	18 ^{+0.5} ₀	30 ⁺² ₀	18±0.2	12 ⁺² ₀	30 ^{+0.10} ₀	30		
~800	TLA1.6	TLC 1.6	TLC 1.6RE								
~1250	TLA2.5	TLC 2.5	TLC 2.5RE	22 ^{+0.5} ₀	37 ⁺³ ₀	22±0.2	16 ⁺² ₀	45 ^{+0.10} ₀	30		
~2000	TLA 4	TLC 4	TLC 4RE	28 ^{+0.5} ₀	46 ⁺⁴ ₀	28±0.2	20 ⁺² ₀	60 ^{+0.12} ₀	35		
~3500	TLA 6	TLC 6	TLC 6RE								
~5500	TLA10	TLC 10	TLC 10RE								
~6500	TLA16										
~8500	TLA 25							100 ^{+0.14} ₀	40		



Class Designation

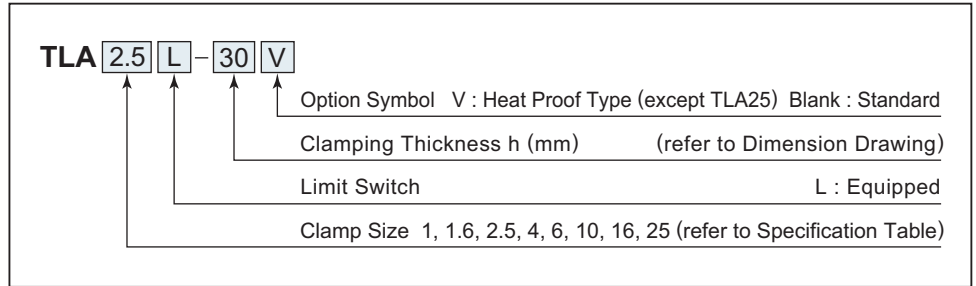

Specifications

MODEL		TLA1	TLA1.6	TLA2.5	TLA4	TLA6	TLA10	TLA16	TLA25	
Holding Force	At Air Pressure 0.49 MPa (kN)	9.8	15.6	24.5	39.2	61.7	98	156	245	
	At Air Pressure 0.39 MPa (kN)	9.8	15.6	24.5	39.2	61.7	98	156	245	
	At Air Pressure 0 MPa (kN)	3.92	6.17	9.8	15.6	24.5	39.2	61.7	98.0	
Fixing Force	At Air Pressure 0.49 MPa (kN)	3.92	6.17	9.8	15.6	24.5	39.2	61.7	98.0	
Residual Fixing Force ※	At Air Pressure 0 MPa (kN)	2.94	4.90	7.84	11.7	19.6	31.3	49.0	78.4	
Full Stroke	: X (mm)	2.2	2.2	2.2	2.6	2.6	2.8	3.0	3.4	
Clamp Stroke	: Y (mm)	1.0	1.0	1.0	1.2	1.2	1.2	1.2	1.4	
Safety Stroke	: Z (mm)	1.2	1.2	1.2	1.4	1.4	1.6	1.8	2.0	
Cylinder Capacity	For Clamping (cm ³)	43	70	115	219	350	607	1116	1993	
	For Unclamping (cm ³)	39	63	104	197	318	560	1046	1869	
Working Ambient Temperature	(°C)	0 ~ 70 (5 ~ 120 with heat proof type)								0 ~ 70
Mass	(kg)	2.3	3.2	4.2	7.8	13.0	25.0	43.0	85.0	

※ Fixing forces when air pressure becomes 0 from 0.49 MPa. Working air pressure 0.39 ~ 0.49 MPa Proof Pressure 0.68 MPa

Dimensions

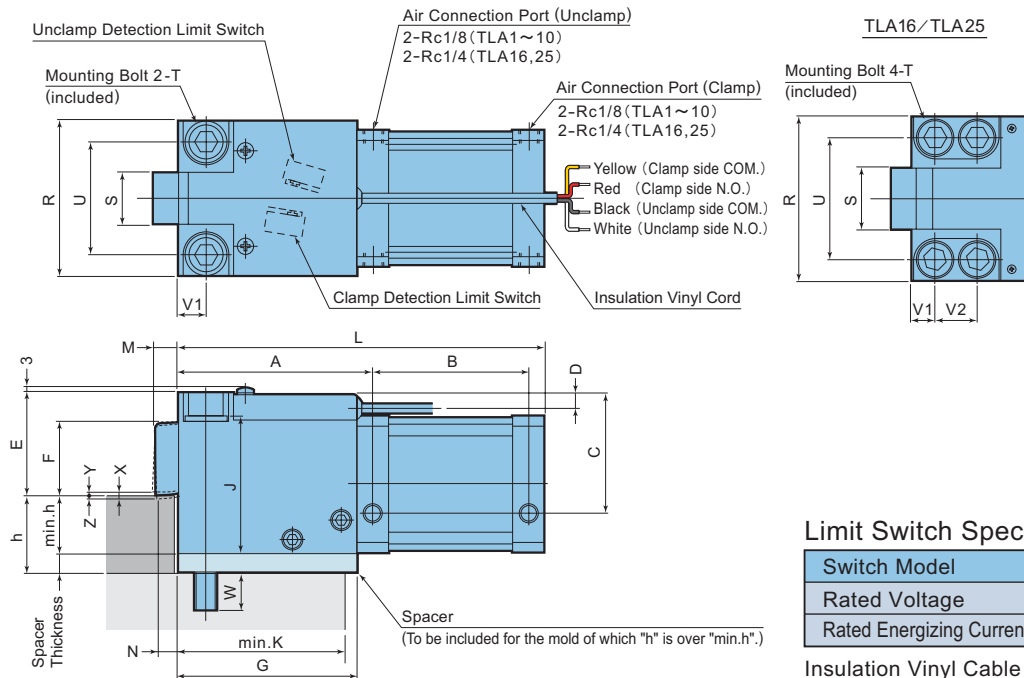

Remarks

- Machining tolerance of clamping thickness "h" should be ±0.3 mm.
- Each mounting bolts should have below strength classifications.
 TLA1 ~ 6 : 12.9
 TLA10~25 : 10.9
- Hexagon cap plug shall be provided for 2 air connection ports out of 4.
- Speed controller is not necessary for air pressure circuit.
- "W" dimension varies according to "h" dimension as well as the length of mounting bolt. Confirm on the final specification sheet.

Limit Switch Specifications (YAMATAKE)

Switch Model	SSM33A1	
Rated Voltage	AC250V	DC30V
Rated Energizing Current (Resistive Load)	2A	2A

Insulation Vinyl Cable Length : 3 m (oil proof type, 0.5 mm²)

Dimension Table

MODEL	A	B	C	D	E	F	G	J	min.h	min.K	L	M	N	R	S	T	U	V1	V2	W
TLA 1	86	72	48	8	45	30	78	57	20	50	166	10.3	7	54	16	M 8	33	8	—	13 ~ 18
TLA 1.6	89	77	54	8	48	32	81	63	25	68	174	12	8	68	22	M10	50	12	—	17 ~ 22
TLA 2.5	99	80	62	8	53	38	91	71	30	90	187	13	9	80	27	M12	58	14	—	19 ~ 24
TLA 4	118.5	90.5	73	8	73	57	110.5	87	30	74	217	15	10	100	35	M16	72	18	—	23 ~ 28
TLA 6	133.5	96.5	93	8	88	72	125.5	103	35	86	238	16	11	120	45	M20	86	21	—	32 ~ 37
TLA 10	159	113	105	8	108	93	150	124	40	130	280	18.4	12	146	55	M24	105	25	—	36 ~ 41
TLA 16	191	138	137	8	144	102	181	160	40	180	340	21.7	14	170	65	M24	128	25	45	40 ~ 45
TLA 25	235	160	167	8.5	174	129	221	194	50	220	410	25.2	16	210	75	M30	158	31	55	46 ~ 51



Class Designation

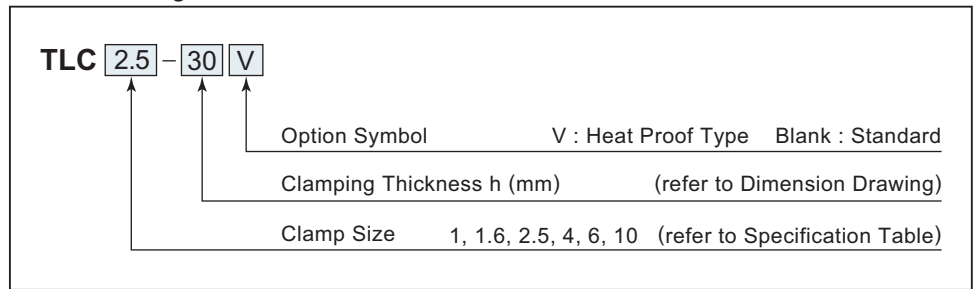

Specifications (Other specifications than specified here are same with TLA)

MODEL	TLC1	TLC1.6	TLC2.5	TLC4	TLC6	TLC10
Full Stroke : X (mm)	3.0	3.0	3.0	3.8	3.8	4.2
Clamp Stroke : Y (mm)	1.0	1.0	1.0	1.2	1.2	1.2
Safety Stroke : Z (mm)	2.0	2.0	2.0	2.6	2.6	3.0
Working Ambient Temperature (°C)	0 ~ 70 (5 ~ 120 with heat proof type)					
Mass ※ (kg)	2.4	3.3	4.4	8.2	13.6	25.9

※ Varies according to the T block dimension.

Dimensions

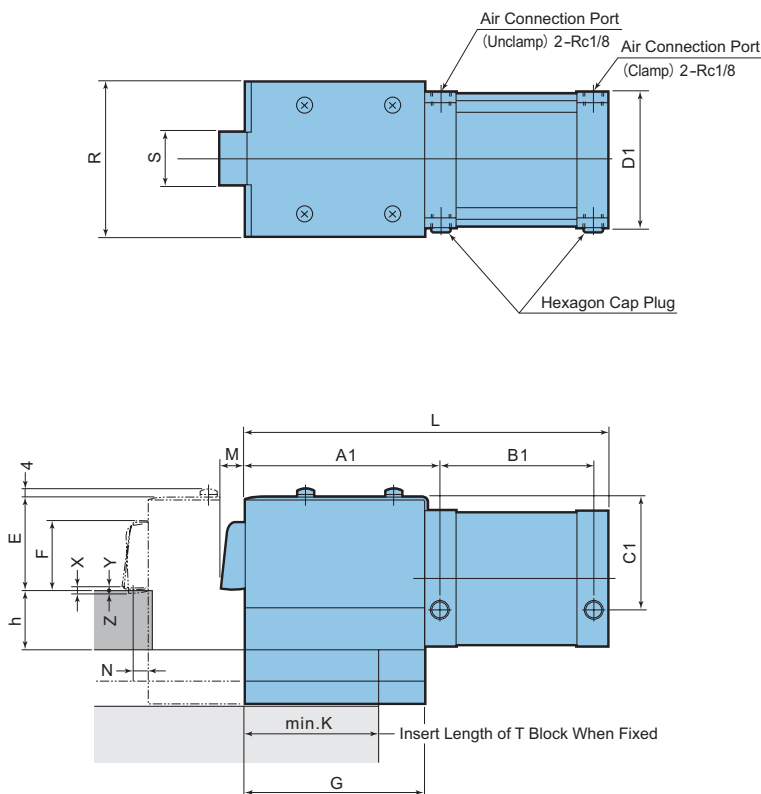

T slot and T block Dimension

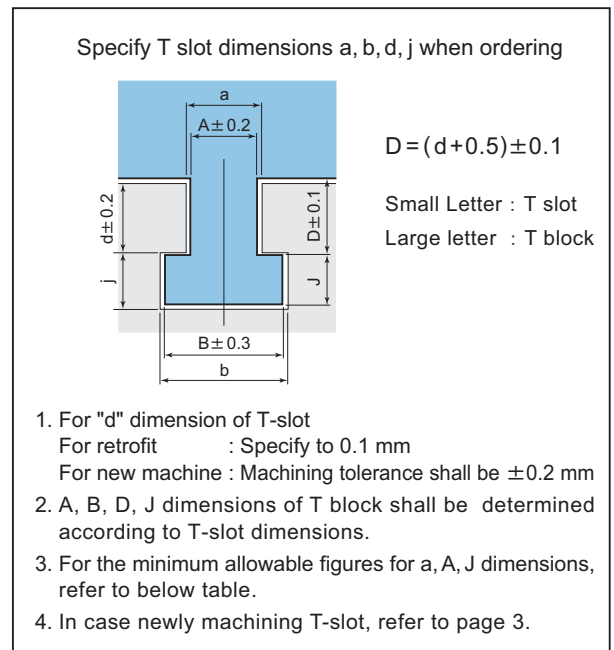

Remarks

- Tolerance of h (clamp thickness) should be ± 0.3 mm.
- Hexagon cap plug shall be provided for 2 air connection ports out of 4.
- Speed controller is not necessary for air pressure circuit.

Dimension Table

(mm)

MODEL	A1	B1	C1	D1	E	F	G	min.h	min.K	L	M	N	R	S	min.a	min.A	min.j
TLC 1	86	72	46	50	44	28	78	20	65	166	12	7	54	16	10	9	8
TLC 1.6	89	77	49	60	44	30.5	81	25	68	174	12	7	68	22	12	11	9
TLC 2.5	99	80	58	70	49	36	91	30	73	187	13	7.5	80	27	14	13	11
TLC 4	118.5	90.5	71	90	72	55.5	110.5	30	83	217	16	9	100	35	16	15	13
TLC 6	133.5	96.5	91	110	87	70	125.5	35	92	238	18	10	120	45	20	18.5	15
TLC 10	159	113	103	135	107	87	150	40	112	280	22	11.5	146	55	23	21.5	17



Class Designation

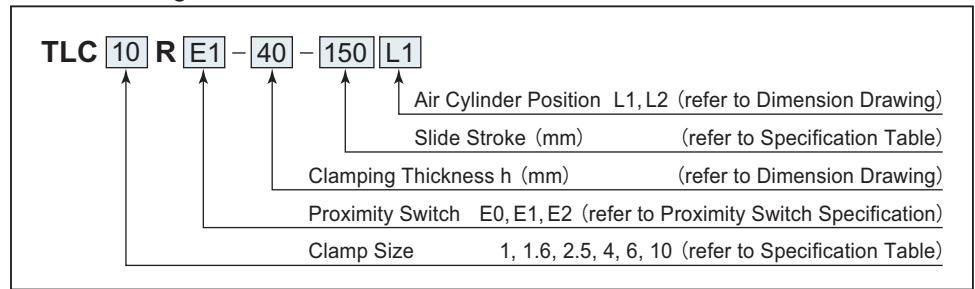

Specifications (Other specifications than specified here are same with TLA)

MODEL	TLC1RE	TLC1.6RE	TLC2.5RE	TLC4RE	TLC6RE	TLC10RE
Full Stroke : X (mm)	3.0	3.0	3.0	3.8	3.8	4.2
Clamp Stroke : Y (mm)	1.0	1.0	1.0	1.2	1.2	1.2
Safety Stroke : Z (mm)	2.0	2.0	2.0	2.6	2.6	3.0
Slide Stroke (mm)	50 ~ 150			50 ~ 200		50~300
Slide Speed (mm/s)	30 ~ 80 (adjusted with speed controller)					
Working Ambient Temperature (°C)	0 ~ 70					
Mass ※ (kg)	2.6	3.5	5.5	12.0	18.0	28.0

※: Varies according to the slide stroke and the T block dimension.

Dimensions The drawings showing : At air cylinder position L1.

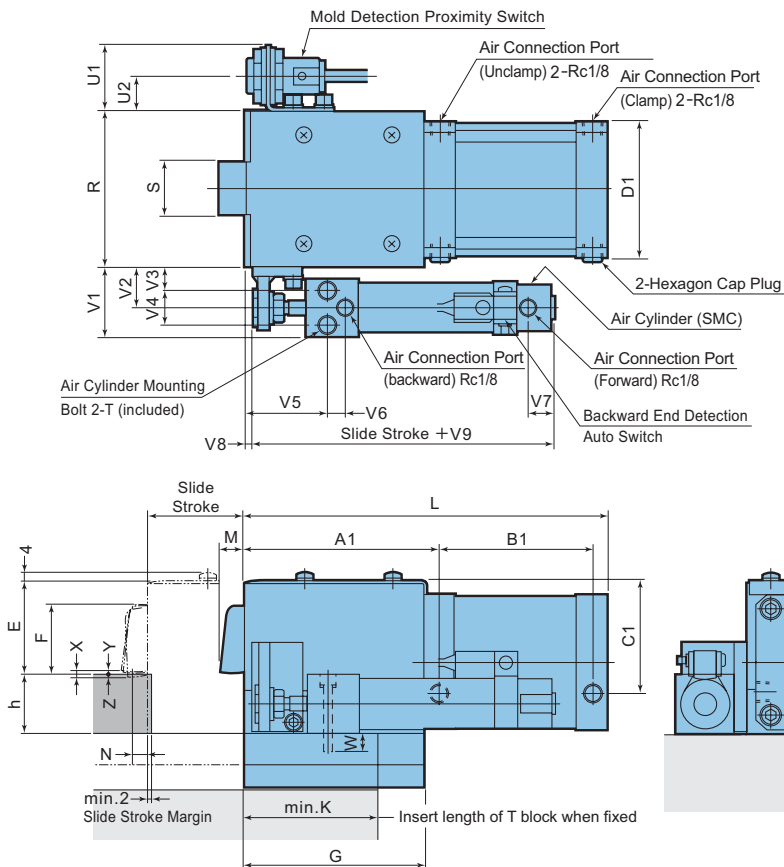

Proximity Switch Specification (OMRON)

Switch Symbol	E0	E1 ※	E2
Switch Model	2-Wire DC※ E2E-X7D1-N	3-Wire DC E2E-X5E1	2-Wire AC E2E-X5Y1
Voltage Range	DC10 ~ 30V	DC10 ~ 40V	AC20 ~ 264V
Leakage Current	Max. 0.8 mA		Max. 1.7 mA
Current Consumption		Max. 13 mA	
Control Output (Switching Capacity)	3 ~ 100 mA	200 mA	5 ~ 300 mA

Insulation vinyl cable length : 5m (Oil proof, 0.5 mm²)

Proximity switch shall be specified as per the symbols (E0, E1, E2).

※When using Pascal control box, 3-wire DC type (E1) shall be delivered.

Auto Switch Specifications (SMC)

Switch Model	D-B54L		
Load Voltage	DC24V	AC100V	AC200V
Range of Load Current	5 ~ 50 mA	5 ~ 25mA	5 ~ 12.5mA

Insulation vinyl cable length : 3m (Oil proof, 0.3 mm²)

Remarks

- Tolerance of h (clamp thickness) should be ±0.3 mm.
- For T-slot and T-block dimension, refer to page 5.
- Hexagon cap plug shall be provided for 2 air connection ports at air cylinder side.
- The speed of slide air cylinder should be adjusted by speed controller. Speed controller is not necessary for air pressure circuit for clamp and unclamp.

Dimension Table

MODEL	A1	B1	C1	D1	E	F	G	min.h	min.K	L	M	N	R	S	T	W	U1	U2	U3	V1	V2	V3	V4	V5	V6	V7	V8	V9
TLC 1RE	86	72	46	50	44	28	78	20	65	166	12	7	54	16	M5 × 35	10	34.5	18.5	16	37.2	22	13	18	42.5	9	12	4.5	104
TLC 1.6RE	89	77	49	60	44	30.5	81	25	68	174	12	7	68	22	M5 × 35	10	34.5	18.5	17	37.2	22	13	18	42.5	9	12	4.5	104
TLC 2.5RE	99	80	58	70	49	36	91	30	73	187	13	7.5	80	27	M5 × 35	10	34.5	18.5	17	37.2	22	13	18	42.5	9	12	4.5	104
TLC 4RE	118.5	90.5	71	90	72	55.5	110.5	30	83	217	16	9	100	35	M8 × 45	10	34.5	18.5	19	47.2	26	14	24	53	13	12	8	117
TLC 6RE	133.5	96.5	91	110	87	70	125.5	35	92	238	18	10	120	45	M8 × 45	10	34.5	18.5	19	47.2	26	14	24	58	13	12	13	117
TLC 10RE	159	113	103	135	107	87	150	40	112	280	22	11.5	146	55	M12 × 70	17	34.5	18.5	19	77.3	45	24.5	41	73	16	14	11	155

Specifications

MODEL	GSC ①-1 ③	GSC ①-2 ③
Fluid used	Air	
Type of Seal	Metal Seal	
Solenoid Valve	2 Position Double	
Maximum Pressure	0.7 MPa	
Proof Pressure	1.0 MPa	
Fluid Temperature Range	-5 ~ 60 °C	
Orifice Area	15mm ²	32.4mm ²
Air Piping Diameter	∅ 6	∅ 10
Protection Structure	Dust Proof	
Oil Supply	Nil	

Class Designation

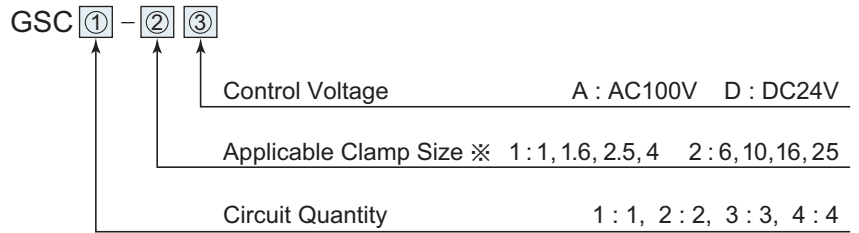

※ : Applicable clamp size shown are for the case when 4 clamps are used per one circuit. When 5 clamps are being used per one circuit, contact us for details.

Remark : The minimum air pressure necessary for unclamp action is 0.39 MPa. Be sure to use at more than 0.39 MPa air pressure.

Dimensions

GSC ①-1 ③

2-∅7 hole Mounting Bolt M6×16 (included)

Solenoid Valve for Slider VFS2200 (SMC)

Solenoid Valve for Clamp VFS2200 (SMC)

Terminal Board

Air Regulator

Air Filter

Pressure Gauge

PA Port (Air Supply) Rc1/4

Pressure Switch IS1000-01S (SMC) Lead Cable Length: 0.5m

Lead Cable Hole G3/4

Manifold with Control Unit VV5FS2-01T1-0[Number of circuit+2]1-02-F

GSC ①-2 ③

2-∅9 hole Mounting Bolt M8×16 (included)

Solenoid Valve for Slider VFS3200 (SMC)

Solenoid Valve for Clamp VFS3200 (SMC)

Terminal Board

Air Regulator

Air Filter

Pressure Gauge

PA Port (Air Supply) Rc1/2

Pressure Switch IS1000-01S (SMC) Lead Cable Length: 0.5m

Lead Cable Hole G1 1/4

Manifold with Control Unit VV5FS3-01T-0[Number of circuit+2]1-02-F

Dimension Table

Number of Circuit	GSC ①-1 ③		GSC ①-2 ③		Example
	L 1	Mass	L 2	Mass	
1	355 mm	3.1 kg	417 mm	4.0 kg	Clamp Circuit × 1
2	383 mm	3.6 kg	450 mm	4.7 kg	Clamp Circuit × 2
3	411 mm	4.2 kg	483 mm	5.4 kg	Clamp Circuit × 3
4	439 mm	4.5 kg	516 mm	5.8 kg	Clamp Circuit × 2 Slider Circuit × 2

Specifications are subject to change without prior notice.

QMC-06E-3 2008.03