

Specifications

Model	TRCEX04	TRCEX06	TRCEX10	
Clamping Force ※1	39.2 kN {8800 lbs}	61.7 kN {13800 lbs}	98.0 kN {22000 lbs}	
Clamping Stroke : X	8 mm (Full Stroke)			
Traveling Stroke : S	400 ~ 900 mm (every 25 mm)			
Traveling Speed	0.18 m/sec. (50 Hz) • 0.21 m/sec. (60 Hz)			
Mass ※2	23 kg	25 kg	27 kg	
Dimensions	F	62 mm	78 mm	98 mm
	N	67 mm	73 mm	79 mm
	P	24 mm	16 mm	6 mm

※ Hydraulic pressure 24.5 MPa {3555 psi}

※ Above mass values are for the case of stroke 800 mm. The mass increase or decreases about 0.6 kg per every 100 mm.

Dimensions

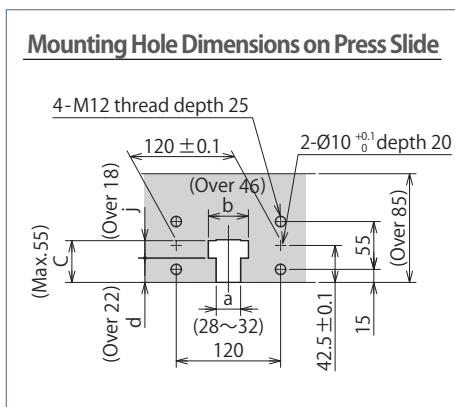
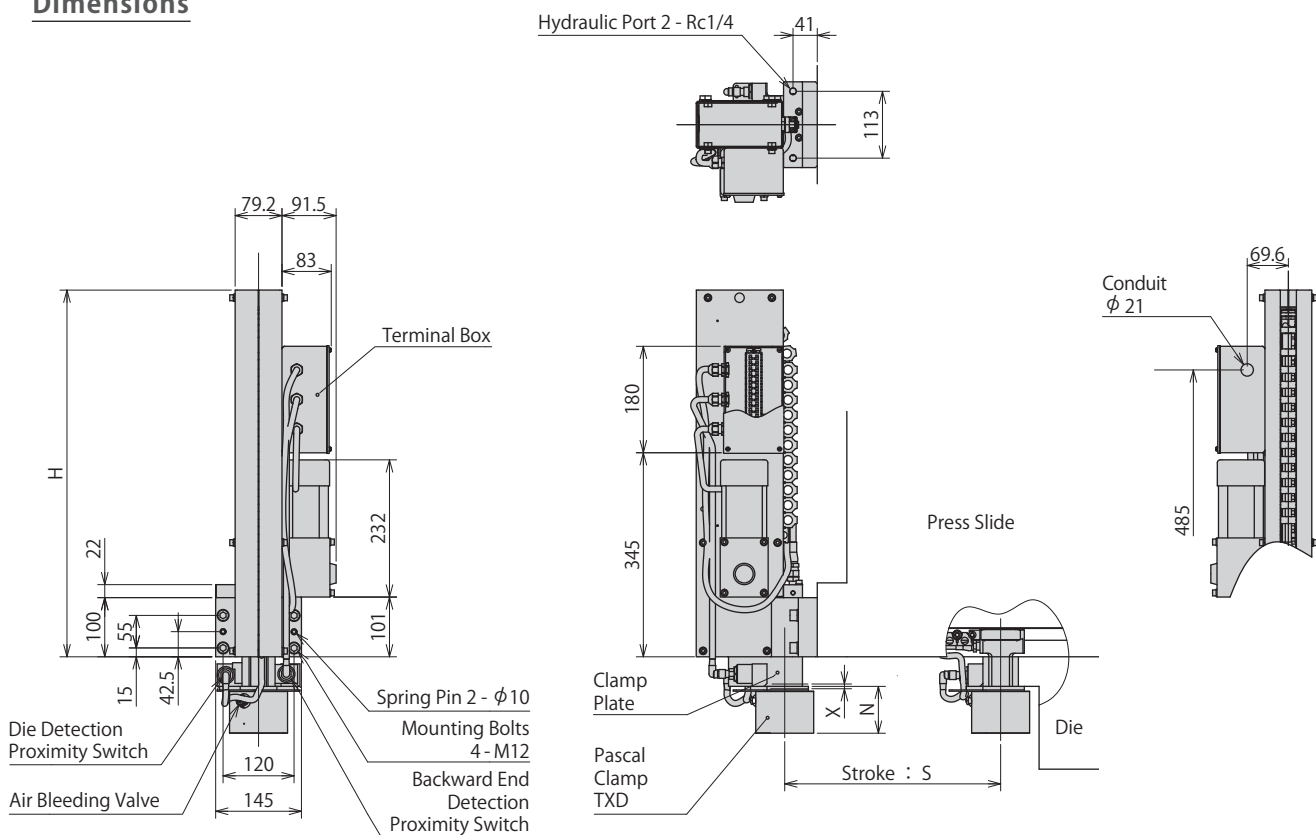

Stroke : S	H	Stroke : S	H
400	520	625 ~ 700	670
425 ~ 500	570	725 ~ 800	720
525 ~ 600	620	825 ~ 900	770