

PRE-ROLLER

MODEL PR

By installing pre-roller, dies will be shifted to the comfortable position where crane or forklift can access and transfer them away.

Total 7 standard models, Removable Straight, Swing and Pillar-equipped heavy duty types, etc, are available.

Preparing variety for die's travel length likewise, ready for the vast needs of application.

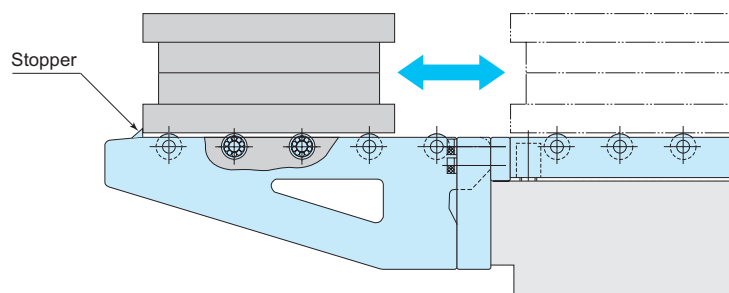
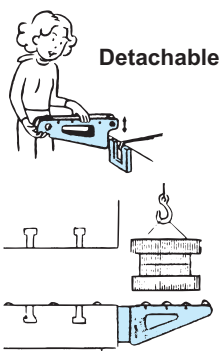
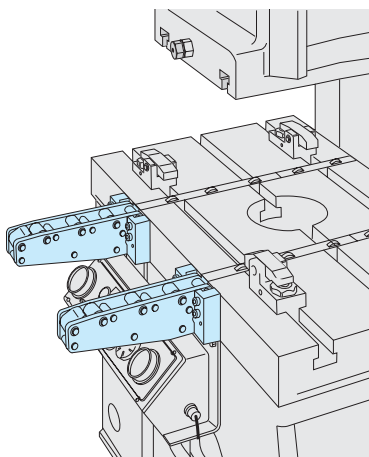
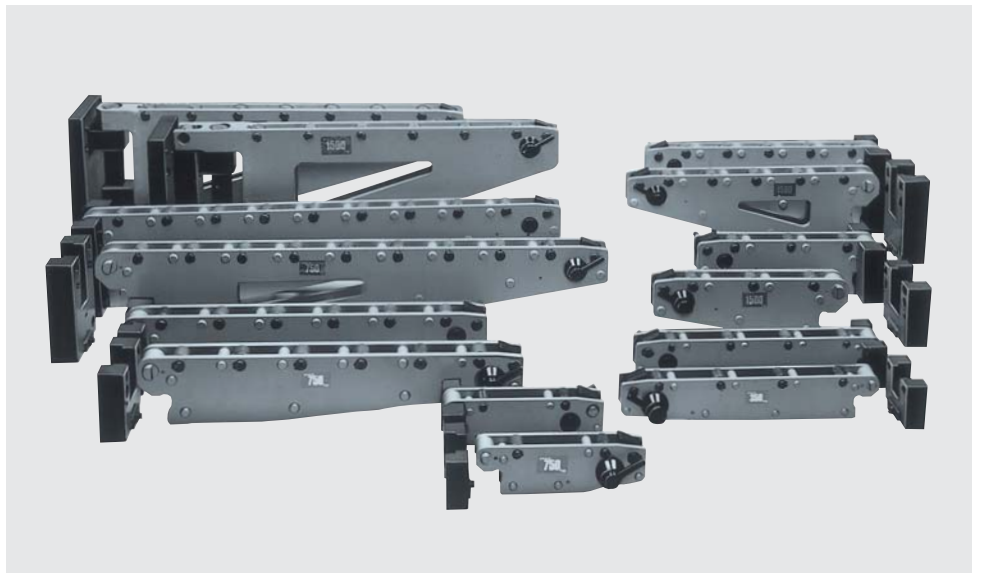
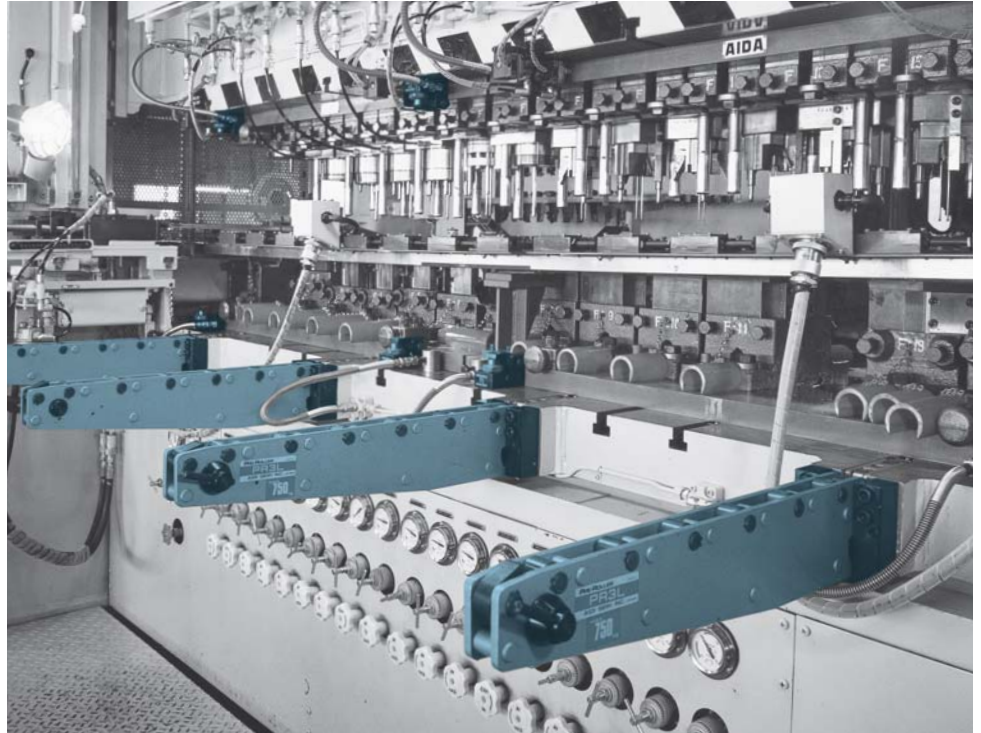

PRE-ROLLER

MODEL **PR**

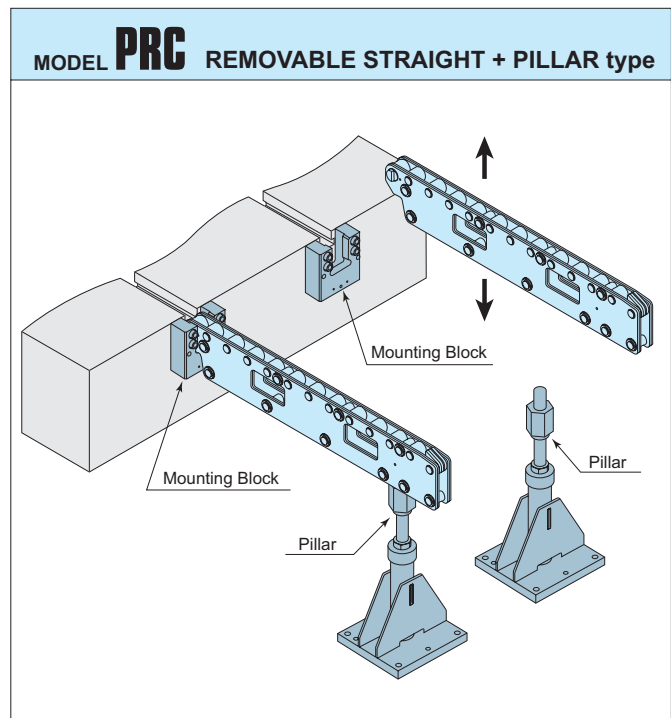
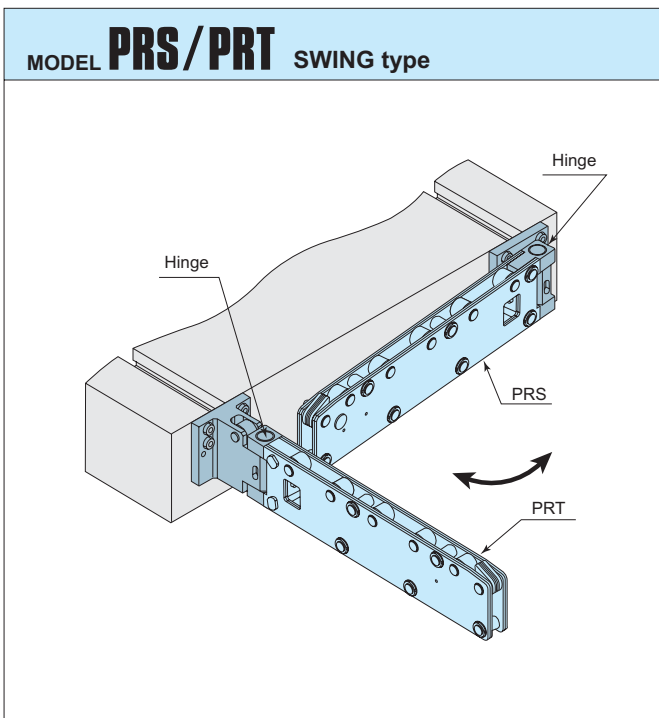
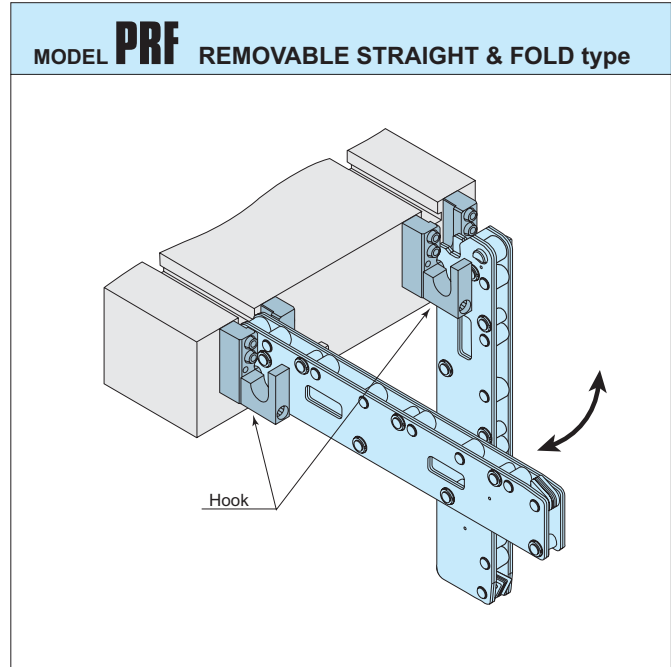
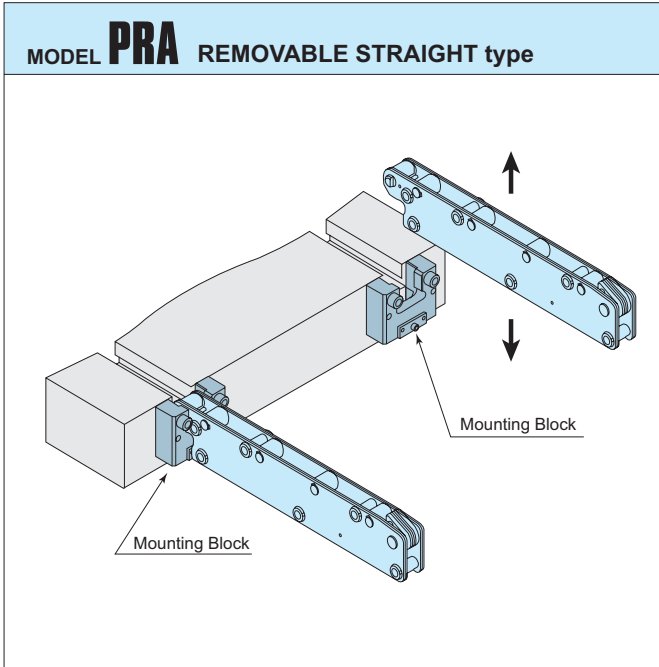

Total 7 standard models are available as below on top of above 4.

MODEL PRA REMOVABLE STRAIGHT type	MODEL PRF REMOVABLE STRAIGHT & FOLD type	MODEL PRS/PRT SWING type	MODEL PRU/PRV SWING + PILLAR type
MODEL PRC REMOVABLE STRAIGHT + PILLAR type	MODEL PRD DOUBLE STRAIGHT + DOUBLE PILLAR type	MODEL PRG DOUBLE SWING + DOUBLE PILLAR type	

Die Travel Range 7.87~78.74 inches

Capacity Range 450~7860 lbs

For product detail such as specifications and dimensions, see pre-roller's catalog No.QDC-06E.