

**Link clamp**

model  
**CLW**

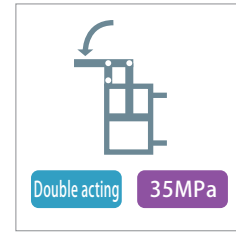

**Compact high performance link clamp with high output and high durability**

**High strength & integrated construction**

Compact with higher output is sought through integrated structure of link pin support section and cylinder body.

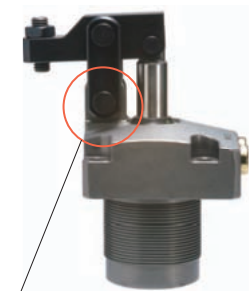

Forged integrated construction

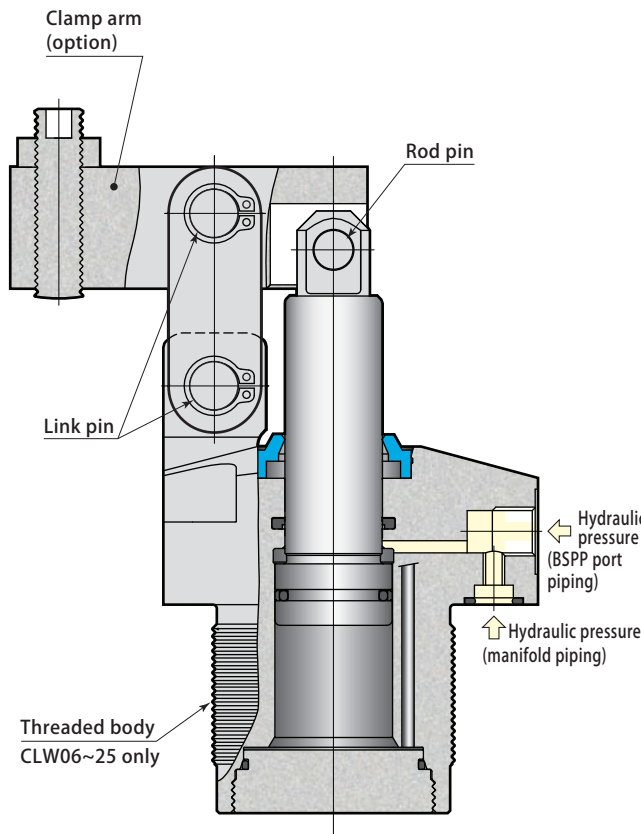

**High pressure coolant & metal chip countermeasure**

Special scraper prevents intrusion of high pressure coolant and metal chips into cylinder.

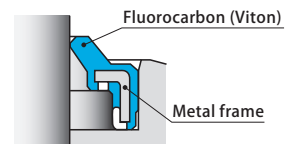

**2-way hydraulic piping**

BSSP piping connection port and manifold piping connection port are available.

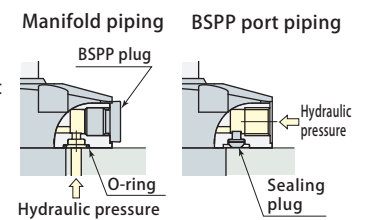

**Three-directional clamp arm**

Three types, each with different clamp arm mounting direction, are available. These may be selected to accommodate fixture layout, such as workpiece or hydraulic piping.

L: Left side F: Forward R: Right side

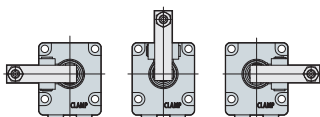

Standard and long clamp arms are available as optional components. Refer to page → 403

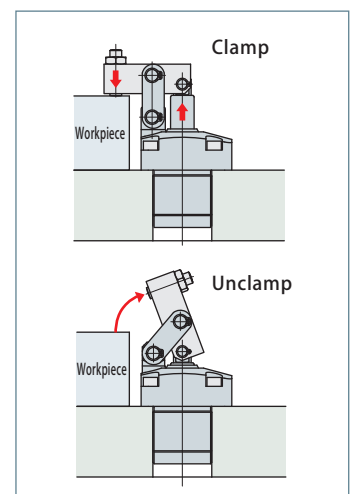

35MPa clamp & work support

Swing clamp

Swing clamp (ROHMHELD-compatible)

Swing clamp (ENERPAC-compatible)

Link clamp

Clamp cylinder

Work support

Option

Specifications

| Model                                      |                           | CLW04                   | CLW06                   | CLW10                   | CLW16                   | CLW25                    |
|--|---------------------------|-------------------------|-------------------------|-------------------------|-------------------------|--------------------------|
| Cylinder force (hydraulic pressure 35 MPa) |                           | (kN) 5.4                | (kN) 8.9                | (kN) 13.3               | (kN) 21.5               | (kN) 35.6                |
| Clamping force *1                          | Hydraulic pressure 35 MPa | (kN) 3.8                | (kN) 5.8                | (kN) 9.2                | (kN) 15.2               | (kN) 24.0                |
|  | Hydraulic pressure 25 MPa | (kN) 2.7                | (kN) 4.1                | (kN) 6.5                | (kN) 10.8               | (kN) 17.2                |
|  | Hydraulic pressure 15 MPa | (kN) 1.6                | (kN) 2.5                | (kN) 3.9                | (kN) 6.5                | (kN) 10.3                |
| Standard clamp arm length (LH)             |                           | (mm) 42                 | (mm) 50                 | (mm) 56.5               | (mm) 69.5               | (mm) 87.5                |
| Cylinder inner diameter                    |                           | (mm) 14                 | (mm) 18                 | (mm) 22                 | (mm) 28                 | (mm) 36                  |
| Rod diameter                               |                           | (mm) 12                 | (mm) 14                 | (mm) 18                 | (mm) 22.4               | (mm) 28                  |
| Effective area (clamp)                     |                           | (cm <sup>2</sup> ) 1.54 | (cm <sup>2</sup> ) 2.54 | (cm <sup>2</sup> ) 3.80 | (cm <sup>2</sup> ) 6.16 | (cm <sup>2</sup> ) 10.18 |
| Full stroke                                |                           | (mm) 23.5               | (mm) 26                 | (mm) 29.5               | (mm) 36                 | (mm) 45                  |
| Clamp stroke                               |                           | (mm) 20.5               | (mm) 23                 | (mm) 26.5               | (mm) 33                 | (mm) 42                  |
| Stroke margin                              |                           | (mm) 3.0                | (mm) 3                  | (mm) 3                  | (mm) 3                  | (mm) 3                   |
| Max. oil flow rate                         |                           | (ℓ /min) 0.38           | (ℓ /min) 0.69           | (ℓ /min) 1.18           | (ℓ /min) 2.39           | (ℓ /min) 5.08            |
| Cylinder capacity                          | Clamp                     | (cm <sup>3</sup> ) 3.6  | (cm <sup>3</sup> ) 6.6  | (cm <sup>3</sup> ) 11.2 | (cm <sup>3</sup> ) 22.2 | (cm <sup>3</sup> ) 45.8  |
|  | Unclamp                   | (cm <sup>3</sup> ) 1.0  | (cm <sup>3</sup> ) 2.6  | (cm <sup>3</sup> ) 3.7  | (cm <sup>3</sup> ) 8.0  | (cm <sup>3</sup> ) 18.1  |
| Mass                                       |                           | (kg) 0.9                | (kg) 1.7                | (kg) 2.3                | (kg) 4.4                | (kg) 7.4                 |

Working pressure range: 1 ~ 35 MPa (CLW04: 3 ~ 35 MPa) Proof pressure: 52.5 MPa Operating temperature: 0 ~ 70° C

Fluid used: General mineral based hydraulic oil (ISO-VG32 equivalent)

\*1: This is when standard clamp arm is mounted (refer to section on G1 series on page → 403).

Clamping force varies depending on clamp arm length. Refer to performance table (page → 393), performance diagram (page → 394) for details.

Fluorocarbon has been adopted for seal sections where cutting fluid is applied, as a measure for the use of chlorine-based cutting fluid (this is not thermal resistant specification).

Model designation

CLW①-②

(Example: CLW16-F)

① Size (refer to specification table)

② Clamp arm mounting direction

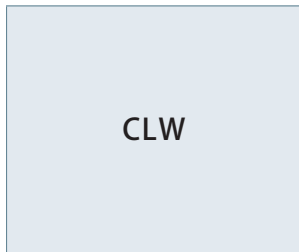

- 04
- 06
- 10
- 16
- 25

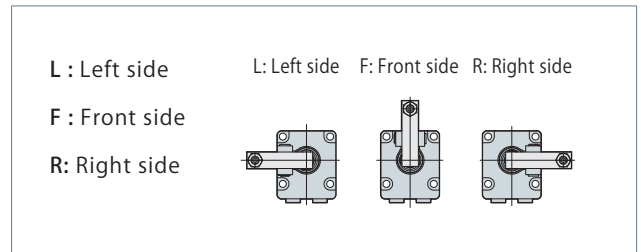

Piping method

Hydraulic circuit diagram (reference)

BSPB port piping

Manifold piping

Mounting: Threaded body + locknut

Mounting: Upper flange + mounting screw

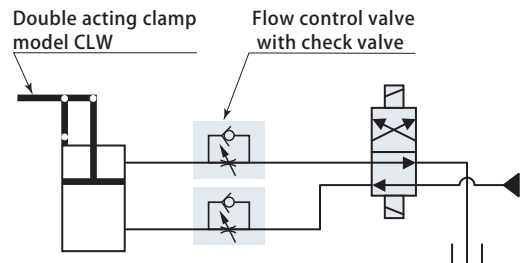
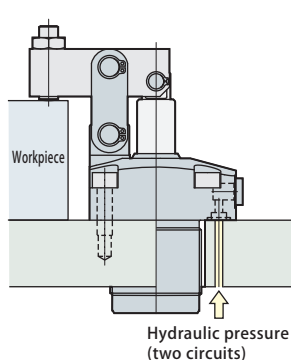
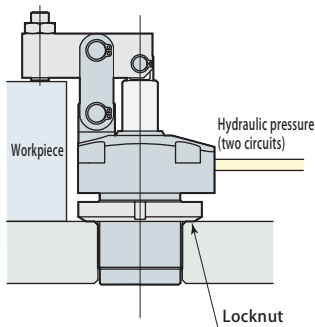

Use flow control valve for meter-in control. Using it in meter-out control results in abnormally high pressure due to back pressure on unclamping side during clamping, leading to malfunction. Only for CLW04-□, flow control valve model VCH can be mounted for manifold piping.

Note: CLW04 has no threaded body.

Performance table

Clamping force varies depending on clamp arm length and hydraulic pressure.

Select an appropriate clamp model based on considerations for clamp arm length, working hydraulic pressure and mounting dimensions.

(Refer to next page for details on values that do not appear on performance table.)

Note: With link clamps, force acting on link mechanism becomes larger as arm becomes shorter. Do not use the product in the nonusable range.

How to read performance table (Example 1)

For clamp arm length (LH) of 60 mm and where clamping force of 4.3 kN or more is necessary, the working hydraulic pressure for each model is:

- Not usable with CLW04
- 35 MPa for CLW06
- 20 MPa for CLW10
- 10 MPa for CLW16
- 5 MPa for CLW25

How to read performance table (Example 2)

When working hydraulic pressure is 25 MPa with CLW10, clamping force necessary for clamp arm length (LH) is:

- 1.6 kN for LH = 160 mm
- 3.8 kN for LH = 80 mm
- 8.2 kN for LH = 50 mm
- Not usable with LH = 40mm

F: Clamping force (kN)    P: Working pressure (MPa)    LH: Clamp arm length (mm)

**CLW 04**     $F = \frac{2.56 \times P}{LH - 18.5}$     indicates nonusable range

| Hydraulic pressure (MPa)    | Cylinder force (kN) | Clamping force (kN)      |      |     |     |     |     |     |     | Min. arm length Min. LH (mm) |
|-----------------------------|---------------------|--------------------------|------|-----|-----|-----|-----|-----|-----|------------------------------|
|                             |                     | Clamp arm length LH (mm) |      |     |     |     |     |     |     |                              |
|                             |                     | 30                       | 35   | 42  | 50  | 60  | 80  | 100 | 120 |                              |
| 35                          | 5.4                 |                          |      | 3.8 | 2.8 | 2.2 | 1.5 | 1.1 | 0.9 | 42                           |
| 30                          | 4.6                 |                          |      | 3.3 | 2.4 | 1.9 | 1.2 | 0.9 | 0.8 | 35.3                         |
| 25                          | 3.9                 |                          | 3.9  | 2.7 | 2.0 | 1.5 | 1.0 | 0.8 | 0.6 | 30.5                         |
| 20                          | 3.1                 | 4.5                      | 3.1  | 2.2 | 1.6 | 1.2 | 0.8 | 0.6 | 0.5 | 30                           |
| 15                          | 2.3                 | 3.3                      | 2.3  | 1.6 | 1.2 | 0.9 | 0.6 | 0.5 | 0.4 | ↑                            |
| 10                          | 1.5                 | 2.2                      | 1.6  | 1.1 | 0.8 | 0.6 | 0.4 | 0.3 | 0.3 | ↑                            |
| 5                           | 0.8                 | 1.1                      | 0.8  | 0.5 | 0.4 | 0.3 | 0.2 | 0.2 | 0.1 | ↑                            |
| 3                           | 0.5                 | 0.7                      | 0.5  | 0.3 | 0.2 | 0.2 | 0.1 | 0.1 | 0.1 | 30                           |
| Max. working pressure (MPa) |                     | 24.4                     | 29.7 | 35  | 35  | 35  | 35  | 35  | 35  |                              |

**CLW 06**     $F = \frac{4.81 \times P}{LH - 21.0}$     indicates nonusable range

| Hydraulic pressure (MPa)    | Cylinder force (kN) | Clamping force (kN)      |      |     |     |     |     |     | Min. arm length Min. LH (mm) |
|-----------------------------|---------------------|--------------------------|------|-----|-----|-----|-----|-----|------------------------------|
|                             |                     | Clamp arm length LH (mm) |      |     |     |     |     |     |                              |
|                             |                     | 35                       | 45   | 50  | 60  | 80  | 100 | 120 |                              |
| 35                          | 8.9                 |                          |      | 5.8 | 4.3 | 2.9 | 2.1 | 1.7 | 50                           |
| 30                          | 7.6                 |                          | 6.0  | 5.0 | 3.7 | 2.4 | 1.8 | 1.5 | 41.5                         |
| 25                          | 6.4                 |                          | 5.0  | 4.1 | 3.1 | 2.0 | 1.5 | 1.2 | 35.5                         |
| 20                          | 5.1                 | 6.9                      | 4.0  | 3.3 | 2.5 | 1.6 | 1.2 | 1.0 | 35                           |
| 15                          | 3.8                 | 5.2                      | 3.0  | 2.5 | 1.9 | 1.2 | 0.9 | 0.7 | ↑                            |
| 10                          | 2.5                 | 3.4                      | 2.0  | 1.7 | 1.2 | 0.8 | 0.6 | 0.5 | ↑                            |
| 5                           | 1.3                 | 1.7                      | 1.0  | 0.8 | 0.6 | 0.4 | 0.3 | 0.2 | ↑                            |
| 1                           | 0.3                 | 0.3                      | 0.2  | 0.2 | 0.1 | 0.1 | 0.1 | 0.1 | 35                           |
| Max. working pressure (MPa) |                     | 24.6                     | 32.3 | 35  | 35  | 35  | 35  | 35  |                              |

**CLW 10**     $F = \frac{8.38 \times P}{LH - 24.5}$     indicates nonusable range

| Hydraulic pressure (MPa)    | Cylinder force (kN) | Clamping force (kN)      |      |      |     |     |     |     |     | Min. arm length Min. LH (mm) |      |
|-----------------------------|---------------------|--------------------------|------|------|-----|-----|-----|-----|-----|------------------------------|------|
|                             |                     | Clamp arm length LH (mm) |      |      |     |     |     |     |     |                              |      |
|                             |                     | 40                       | 50   | 56.5 | 60  | 80  | 100 | 120 | 140 |                              | 160  |
| 35                          | 13.3                |                          |      | 9.2  | 8.3 | 5.3 | 3.9 | 3.1 | 2.5 | 2.2                          | 56.5 |
| 30                          | 11.4                |                          | 9.9  | 7.9  | 7.1 | 4.5 | 3.3 | 2.6 | 2.2 | 1.9                          | 47   |
| 25                          | 9.5                 |                          | 8.2  | 6.5  | 5.9 | 3.8 | 2.8 | 2.2 | 1.8 | 1.5                          | 40.5 |
| 20                          | 7.6                 | 10.8                     | 6.6  | 5.2  | 4.7 | 3.0 | 2.2 | 1.8 | 1.5 | 1.2                          | 40   |
| 15                          | 5.7                 | 8.1                      | 4.9  | 3.9  | 3.5 | 2.3 | 1.7 | 1.3 | 1.1 | 0.9                          | ↑    |
| 10                          | 3.8                 | 5.4                      | 3.3  | 2.6  | 2.4 | 1.5 | 1.1 | 0.9 | 0.7 | 0.6                          | ↑    |
| 5                           | 1.9                 | 2.7                      | 1.6  | 1.3  | 1.2 | 0.8 | 0.6 | 0.4 | 0.4 | 0.3                          | ↑    |
| 1                           | 0.4                 | 0.5                      | 0.3  | 0.3  | 0.2 | 0.2 | 0.1 | 0.1 | 0.1 | 0.1                          | 40   |
| Max. working pressure (MPa) |                     | 24.4                     | 31.7 | 35   | 35  | 35  | 35  | 35  | 35  | 35                           |      |

**CLW 16**     $F = \frac{16.90 \times P}{LH - 30.5}$     indicates nonusable range

| Hydraulic pressure (MPa)    | Cylinder force (kN) | Clamping force (kN)      |      |      |      |     |     |     |     |     | Min. arm length Min. LH (mm) |
|-----------------------------|---------------------|--------------------------|------|------|------|-----|-----|-----|-----|-----|------------------------------|
|                             |                     | Clamp arm length LH (mm) |      |      |      |     |     |     |     |     |                              |
|                             |                     | 50                       | 60   | 69.5 | 80   | 100 | 120 | 140 | 160 | 180 |                              |
| 35                          | 21.6                |                          |      | 15.2 | 11.9 | 8.5 | 6.6 | 5.4 | 4.6 | 4.0 | 69.5                         |
| 30                          | 18.5                |                          | 17.2 | 13.0 | 10.2 | 7.3 | 5.7 | 4.6 | 3.9 | 3.4 | 58.5                         |
| 25                          | 15.4                |                          | 14.3 | 10.8 | 8.5  | 6.1 | 4.7 | 3.9 | 3.3 | 2.8 | 50.5                         |
| 20                          | 12.3                | 17.3                     | 11.5 | 8.7  | 6.8  | 4.9 | 3.8 | 3.1 | 2.6 | 2.3 | 50                           |
| 15                          | 9.2                 | 13.0                     | 8.6  | 6.5  | 5.1  | 3.6 | 2.8 | 2.3 | 2.0 | 1.7 | ↑                            |
| 10                          | 6.2                 | 8.7                      | 5.7  | 4.3  | 3.4  | 2.4 | 1.9 | 1.5 | 1.3 | 1.1 | ↑                            |
| 5                           | 3.1                 | 4.3                      | 2.9  | 2.2  | 1.7  | 1.2 | 0.9 | 0.8 | 0.7 | 0.6 | ↑                            |
| 1                           | 0.6                 | 0.9                      | 0.6  | 0.4  | 0.3  | 0.2 | 0.2 | 0.2 | 0.1 | 0.1 | 50                           |
| Max. working pressure (MPa) |                     | 24.8                     | 30.9 | 35   | 35   | 35  | 35  | 35  | 35  | 35  |                              |

**CLW 25**     $F = \frac{34.35 \times P}{LH - 37.5}$     indicates nonusable range

| Hydraulic pressure (MPa)    | Cylinder force (kN) | Clamping force (kN)      |      |      |      |      |      |     |     | Min. arm length Min. LH (mm) |      |
|-----------------------------|---------------------|--------------------------|------|------|------|------|------|-----|-----|------------------------------|------|
|                             |                     | Clamp arm length LH (mm) |      |      |      |      |      |     |     |                              |      |
|                             |                     | 60                       | 65   | 87.5 | 100  | 120  | 140  | 160 | 180 |                              | 200  |
| 35                          | 35.6                |                          |      | 24.0 | 19.2 | 14.6 | 11.7 | 9.8 | 8.4 | 7.4                          | 87.5 |
| 30                          | 30.5                |                          |      | 20.6 | 16.5 | 12.5 | 10.1 | 8.4 | 7.2 | 6.3                          | 73   |
| 25                          | 25.5                |                          | 31.2 | 17.2 | 13.7 | 10.4 | 8.4  | 7.0 | 6.0 | 5.3                          | 62.5 |
| 20                          | 20.4                | 30.5                     | 25.0 | 13.7 | 11.0 | 8.3  | 6.7  | 5.6 | 4.8 | 4.2                          | 60   |
| 15                          | 15.3                | 22.9                     | 18.7 | 10.3 | 8.2  | 6.2  | 5.0  | 4.2 | 3.6 | 3.2                          | ↑    |
| 10                          | 10.2                | 15.3                     | 12.5 | 6.9  | 5.5  | 4.2  | 3.4  | 2.8 | 2.4 | 2.1                          | ↑    |
| 5                           | 5.1                 | 7.6                      | 6.2  | 3.4  | 2.7  | 2.1  | 1.7  | 1.4 | 1.2 | 1.1                          | ↑    |
| 1                           | 1.0                 | 1.5                      | 1.2  | 0.7  | 0.5  | 0.4  | 0.3  | 0.3 | 0.2 | 0.2                          | 60   |
| Max. working pressure (MPa) |                     | 23.5                     | 26.3 | 35   | 35   | 35   | 35   | 35  | 35  | 35                           |      |

35MPa clamp & work support

Swing clamp

Swing clamp (ROEMHELD-compatible)

Swing clamp (ENERPAC-compatible)

Link clamp

Clamp cylinder

Work support

Option

Performance diagram

1. Clamping force varies depending on clamp arm length and hydraulic pressure. Use following clamping force calculation formula to obtain clamping force.

Clamping force calculation formula 
$$F = F_c \times \frac{HG}{(LH - HG)} \times \eta$$

2. When using clamp arm with HK dimension that is shorter than those shown in table to the right, determine maximum working pressure using maximum working pressure calculation formula below. Force that applies on link mechanism becomes greater as HK dimension becomes shorter. Exceeding maximum allowable load Fa will result in excessive load on link mechanism, leading to malfunction.

Hydraulic pressure calculation formula 
$$P_a \leq \frac{10 \times F_a \times (LH - HG)}{A (HG \times \eta + LH - HG)}$$

- F : Clamping force kN
- Fc : Cylinder force kN (refer to performance diagram)
- LH=HG+HK: Clamp arm length mm (refer to diagram on right)
- $\eta$  : Output efficiency (0.9)
- Pa : Max. working pressure MPa
- Fa : Link section max. allowable load kN (refer to table below)
- A : Effective area (clamp) cm<sup>2</sup> (refer to specification table)

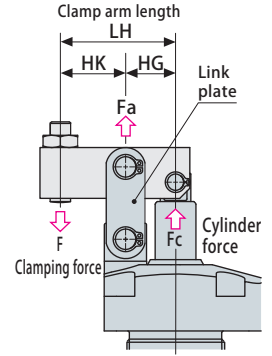

| Model    | CLW04 | CLW06 | CLW10 | CLW16 | CLW25 |
|----------|-------|-------|-------|-------|-------|
| HG (mm)  | 18.5  | 21    | 24.5  | 30.5  | 37.5  |
| LH* (mm) | 42    | 50    | 56.5  | 69.5  | 87.5  |
| Fa (kN)  | 9.2   | 14.7  | 22.5  | 36.7  | 59.6  |

\*: Standard clamp arm length.

CLW 04

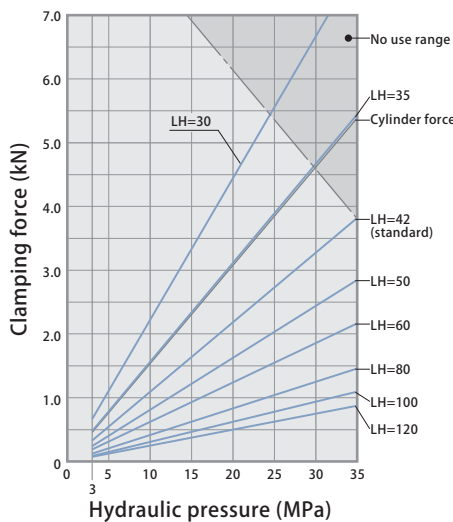

CLW 06

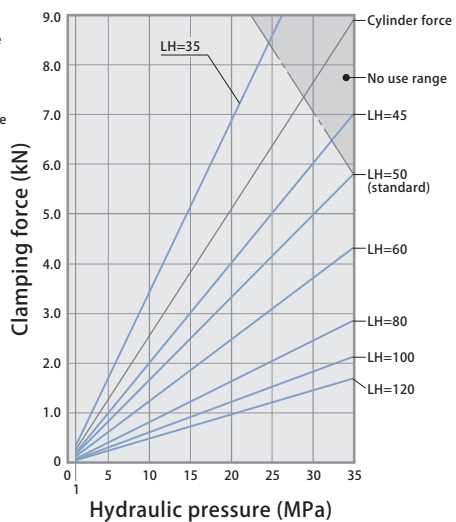

CLW 10

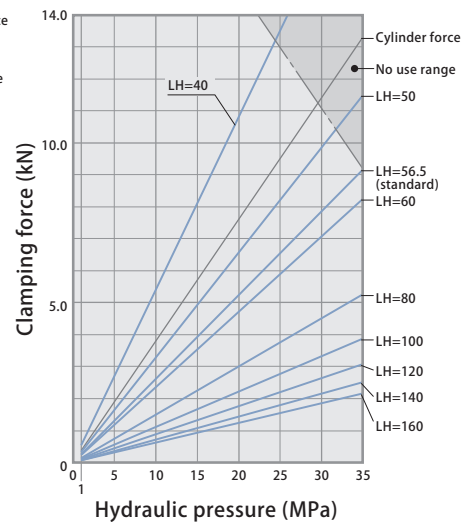

CLW 16

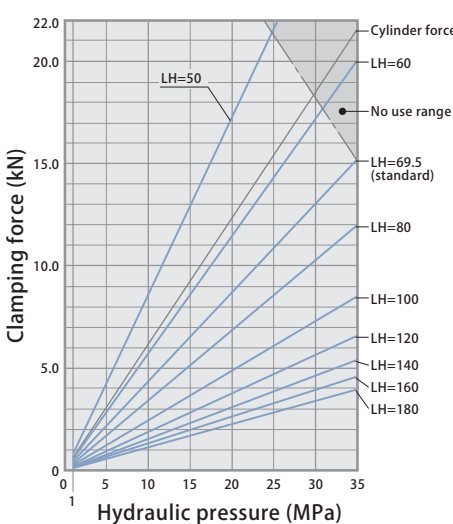

CLW 25

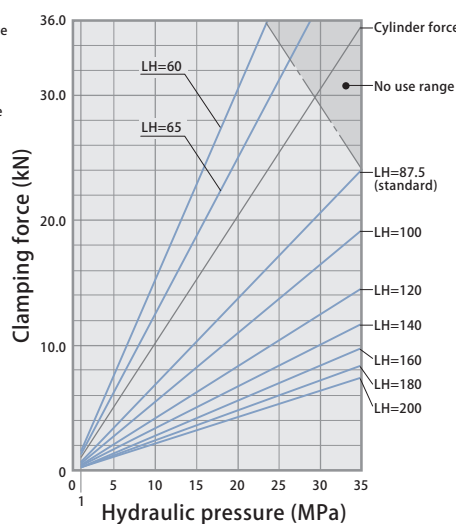

Dimensions

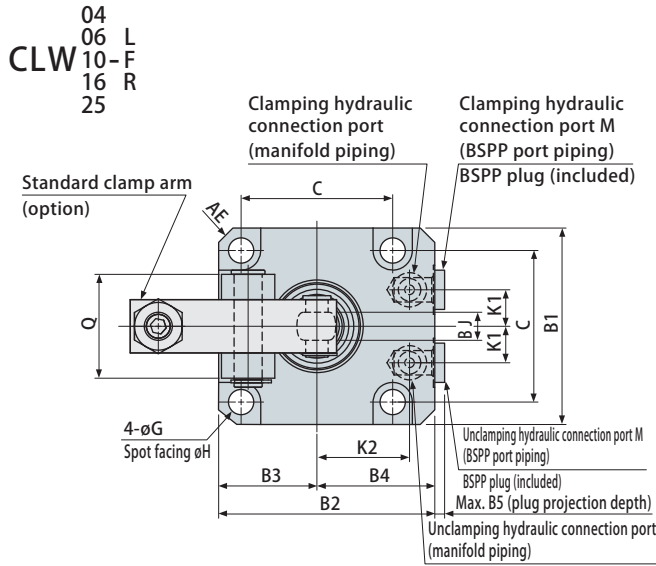

CLW  
04 L  
06 F  
10 R  
16  
25

(mm)

| Model     | CLW04-F <sub>L/R</sub>            | CLW06-L-F <sub>R</sub>            | CLW10-L-F <sub>R</sub>             | CLW16-L-F <sub>R</sub>             | CLW25-L-F <sub>R</sub>             |
|-----------|-----------------------------------|-----------------------------------|------------------------------------|------------------------------------|------------------------------------|
| A         | 100                               | 122                               | 132.5                              | 162                                | 197                                |
| B1        | 50                                | 60                                | 70                                 | 88                                 | 108                                |
| B2        | 60                                | 69                                | 77                                 | 96                                 | 110                                |
| B3        | 25                                | 30                                | 35                                 | 43                                 | 54                                 |
| B4        | 35                                | 39                                | 42                                 | 53                                 | 56                                 |
| B5        | 3.8                               | 3.8                               | 3.8                                | 4.8                                | 4.8                                |
| C         | 40                                | 47                                | 54                                 | 65                                 | 85                                 |
| D         | 26.5                              | 31                                | 32.5                               | 40                                 | 47                                 |
| E         | 35 <sup>0</sup> <sub>-0.2</sub>   | 45 <sup>0</sup> <sub>-0.2</sub>   | 50 <sup>0</sup> <sub>-0.2</sub>    | 60 <sup>0</sup> <sub>-0.2</sub>    | 70 <sup>0</sup> <sub>-0.2</sub>    |
| F         | 31.5                              | 45.2                              | 42.5                               | 51                                 | 63                                 |
| G         | 5.5                               | 6.8                               | 9                                  | 11                                 | 14                                 |
| H         | 10                                | 11                                | 14                                 | 17.5                               | 20                                 |
| J         | 17                                | 17                                | 17                                 | 20                                 | 21                                 |
| K1        | 11                                | 11.5                              | 13                                 | 15                                 | 20                                 |
| K2        | 27.5                              | 30                                | 33                                 | 40                                 | 43                                 |
| L         | 12.5                              | 15                                | 15                                 | 17                                 | 17                                 |
| M *1      | G1/8                              | G1/8                              | G1/8                               | G1/4                               | G1/4                               |
| N         | 52.5                              | 59.5                              | 65                                 | 80                                 | 96                                 |
| P         | 20.5                              | 23                                | 26.5                               | 33                                 | 42                                 |
| Q         | 21                                | 28                                | 37                                 | 46                                 | 56                                 |
| R         | 32                                | 34.5                              | 40.5                               | 49                                 | 61.5                               |
| S         | 12                                | 14                                | 18                                 | 22.4                               | 28                                 |
| T         | 10                                | 12                                | 15                                 | 20                                 | 26                                 |
| U         | 2                                 | 2                                 | 2.5                                | 2.5                                | 2.5                                |
| V         | 6                                 | 6                                 | 8                                  | 11                                 | 13                                 |
| W         | 7                                 | 7                                 | 9                                  | 10.8                               | 14.5                               |
| X         | —                                 | M45×1.5                           | M50×1.5                            | M60×2                              | M70×2                              |
| Y         | 36±0.1                            | 41.5±0.1                          | 45                                 | 54.5                               | 65                                 |
| Z         | 26                                | 30                                | 35.5                               | 44                                 | 53                                 |
| O-ring *2 | P9                                | P9                                | P9                                 | P9                                 | P9                                 |
| AA        | 13                                | 15                                | 19                                 | 25                                 | 32                                 |
| AB        | 6 <sup>+0.012</sup> <sub>0</sub>  | 8 <sup>+0.015</sup> <sub>0</sub>  | 10 <sup>+0.015</sup> <sub>0</sub>  | 14 <sup>+0.018</sup> <sub>0</sub>  | 16 <sup>+0.018</sup> <sub>0</sub>  |
| AC        | 6 <sup>+0.012</sup> <sub>0</sub>  | 6 <sup>+0.012</sup> <sub>0</sub>  | 8 <sup>+0.015</sup> <sub>0</sub>   | 12 <sup>+0.018</sup> <sub>0</sub>  | 14 <sup>+0.018</sup> <sub>0</sub>  |
| AD        | 3                                 | 3                                 | 3                                  | 3                                  | 3                                  |
| AE        | C2.5                              | R5                                | R6                                 | R7                                 | R10                                |
| AF        | —                                 | 43                                | 48                                 | 57.5                               | 67.5                               |
| AG        | —                                 | 10                                | 10                                 | 12                                 | 12                                 |
| BA        | 18.5                              | 21                                | 24.5                               | 30.5                               | 37.5                               |
| BB        | 23.5                              | 29                                | 32                                 | 39                                 | 50                                 |
| BC        | 6                                 | 8                                 | 10                                 | 11                                 | 15                                 |
| BD        | 16                                | 20                                | 25                                 | 31                                 | 38                                 |
| BE        | 59.6                              | 71.7                              | 78.7                               | 98.2                               | 133.5                              |
| BG        | 92.5                              | 107.9                             | 117.4                              | 144.7                              | 189.2                              |
| BH        | About 71°                         | About 70°                         | About 70°                          | About 69°                          | About 72°                          |
| BJ *3     | 6 <sup>-0.1</sup> <sub>-0.2</sub> | 8 <sup>-0.1</sup> <sub>-0.2</sub> | 10 <sup>-0.1</sup> <sub>-0.2</sub> | 11 <sup>-0.1</sup> <sub>-0.2</sub> | 16 <sup>-0.1</sup> <sub>-0.2</sub> |
| CA        | M5                                | M6                                | M8                                 | M10                                | M12                                |
| CB        | 7                                 | 7                                 | 7                                  | 7                                  | 7                                  |
| CC        | 36                                | 47                                | 52                                 | 62                                 | 72                                 |
| DA *4     | STW-6                             | STW-6                             | STW-8                              | STW-12                             | STW-14                             |
| DB *4     | STW-6                             | STW-8                             | STW-10                             | STW-14                             | STW-16                             |

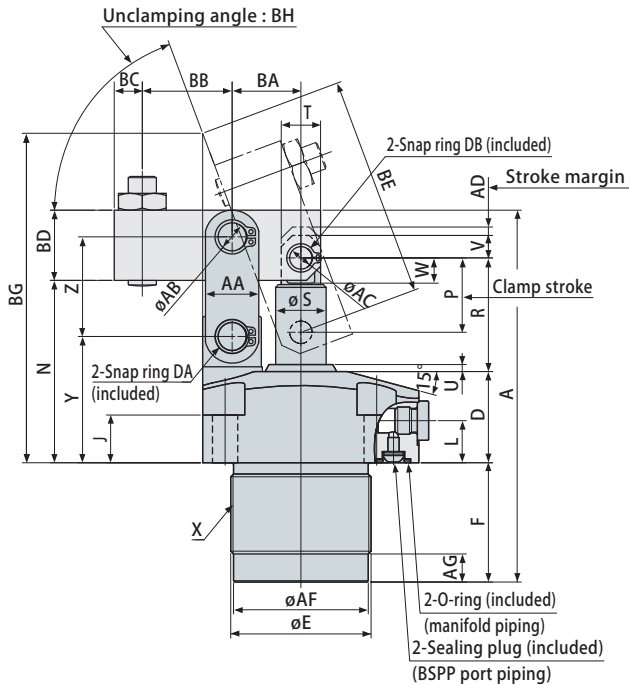

Mounting details

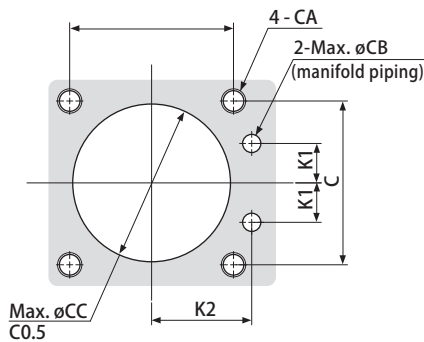

- Note 1. Diagram above represents external contour of CLW□-F. CLW□-L and CLW□-R differ only in terms of mounting direction of clamp arm and otherwise all dimensions are identical to those of CLW□-F.
- The mounting surface finish must be no rougher than Rz 6.3 (ISO4287:1997) for manifold piping.
  - Mounting screws and locknuts are not included.

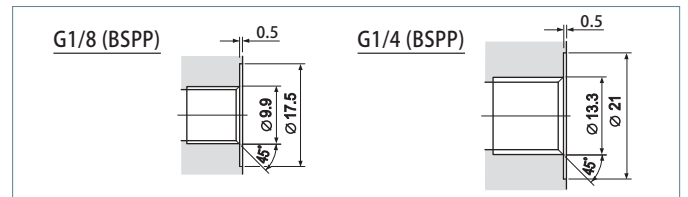

- \*1: Refer to page → 429 for details on BSPP port piping flareless fitting.
- \*2: Material used for O-ring is fluorocarbon (with hardness Hs90).
- \*3: Dimensions of area across flats at tip section of piston rod are shown.
- \*4: Snap ring is made by Ochiai Corporation.

35MPa clamp & work support

Swing clamp

Swing clamp (ROHMHELD-compatible)

Swing clamp (ENERPAC-compatible)

Link clamp

Clamp cylinder

Work support

Option

**Allowable eccentricity of clamp arm**

An eccentric shape clamp arm as shown in diagram on right can be used with link clamp model CLW, if it is not possible to set clamp point at tip section of clamp arm in alignment with center line of piston rod and clamp arm.

Amount of eccentricity, however, must be within allowable eccentricity shown below. Using a clamp arm that exceeds allowable eccentricity results in significant eccentric load on link mechanism and piston rod, leading to malfunction.

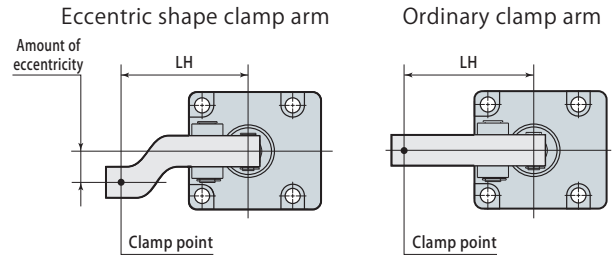

| <b>CLW 04</b>            |                          | ■ indicates nonusable range |    |    |    |    |    |     |     |  |
|--------------------------|--------------------------|-----------------------------|----|----|----|----|----|-----|-----|--|
| Hydraulic pressure (MPa) | Allowable eccentricity   |                             |    |    |    |    |    |     |     |  |
|                          | Clamp arm length LH (mm) |                             |    |    |    |    |    |     |     |  |
|                          | 30                       | 35                          | 42 | 50 | 60 | 70 | 80 | 100 | 120 |  |
| 35                       | ■                        | ■                           | ■  | ■  | 7  | 11 | 16 | 24  | 33  |  |
| 30                       | ■                        | ■                           | ■  | 9  | 15 | 22 | 28 | 41  | 53  |  |
| 25                       | ■                        | ■                           | 6  | 18 | 27 | 36 | 45 | 60  | 60  |  |
| 20                       | ■                        | 6                           | 18 | 27 | 39 | 52 | 60 | ↑   | ↑   |  |
| 15                       | 8                        | 17                          | 29 | 42 | 59 | 60 | ↑  | ↑   | ↑   |  |
| 10                       | 19                       | 32                          | 51 | 60 | 60 | ↑  | ↑  | ↑   | ↑   |  |
| 5                        | 52                       | 60                          | 60 | 60 | 60 | 60 | 60 | 60  | 60  |  |

| <b>CLW 06</b>            |                          | ■ indicates nonusable range |    |    |    |    |    |     |     |  |
|--------------------------|--------------------------|-----------------------------|----|----|----|----|----|-----|-----|--|
| Hydraulic pressure (MPa) | Allowable eccentricity   |                             |    |    |    |    |    |     |     |  |
|                          | Clamp arm length LH (mm) |                             |    |    |    |    |    |     |     |  |
|                          | 35                       | 45                          | 50 | 60 | 70 | 80 | 90 | 100 | 120 |  |
| 35                       | ■                        | ■                           | 8  | 8  | 8  | 8  | 8  | 8   | 8   |  |
| 30                       | ■                        | 8                           | 8  | 8  | 8  | 8  | 8  | 8   | 8   |  |
| 25                       | ■                        | 8                           | 8  | 8  | 8  | 8  | 8  | 8   | 8   |  |
| 20                       | 10                       | 20                          | 23 | 28 | 33 | 38 | 44 | 49  | 60  |  |
| 15                       | 19                       | 43                          | 50 | 65 | 80 | 80 | 80 | 80  | 80  |  |
| 10                       | 37                       | 74                          | 80 | 80 | ↑  | ↑  | ↑  | ↑   | ↑   |  |
| 5                        | 80                       | 80                          | 80 | 80 | 80 | 80 | 80 | 80  | 80  |  |

| <b>CLW 10</b>            |                          | ■ indicates nonusable range |      |    |    |     |     |     |     |  |
|--------------------------|--------------------------|-----------------------------|------|----|----|-----|-----|-----|-----|--|
| Hydraulic pressure (MPa) | Allowable eccentricity   |                             |      |    |    |     |     |     |     |  |
|                          | Clamp arm length LH (mm) |                             |      |    |    |     |     |     |     |  |
|                          | 40                       | 50                          | 56.5 | 60 | 80 | 100 | 120 | 140 | 160 |  |
| 35                       | ■                        | ■                           | 9    | 9  | 9  | 9   | 9   | 9   | 9   |  |
| 30                       | ■                        | 9                           | 11   | 11 | 12 | 13  | 14  | 15  | 16  |  |
| 25                       | ■                        | 16                          | 25   | 30 | 42 | 54  | 66  | 78  | 90  |  |
| 20                       | 9                        | 27                          | 38   | 45 | 80 | 95  | 95  | 95  | 95  |  |
| 15                       | 19                       | 44                          | 60   | 69 | 95 | ↑   | ↑   | ↑   | ↑   |  |
| 10                       | 40                       | 79                          | 95   | 95 | ↑  | ↑   | ↑   | ↑   | ↑   |  |
| 5                        | 95                       | 95                          | 95   | 95 | 95 | 95  | 95  | 95  | 95  |  |

| <b>CLW 16</b>            |                          | ■ indicates nonusable range |      |     |     |     |     |     |     |  |
|--------------------------|--------------------------|-----------------------------|------|-----|-----|-----|-----|-----|-----|--|
| Hydraulic pressure (MPa) | Allowable eccentricity   |                             |      |     |     |     |     |     |     |  |
|                          | Clamp arm length LH (mm) |                             |      |     |     |     |     |     |     |  |
|                          | 50                       | 60                          | 69.5 | 80  | 100 | 120 | 140 | 160 | 180 |  |
| 35                       | ■                        | ■                           | 11   | 11  | 13  | 24  | 34  | 45  | 56  |  |
| 30                       | ■                        | 11                          | 11   | 16  | 32  | 48  | 65  | 81  | 96  |  |
| 25                       | ■                        | 12                          | 23   | 35  | 59  | 83  | 107 | 110 | 110 |  |
| 20                       | 11                       | 29                          | 46   | 64  | 99  | 110 | 110 | ↑   | ↑   |  |
| 15                       | 30                       | 57                          | 83   | 110 | 110 | ↑   | ↑   | ↑   | ↑   |  |
| 10                       | 67                       | 110                         | 110  | ↑   | ↑   | ↑   | ↑   | ↑   | ↑   |  |
| 5                        | 110                      | 110                         | 110  | 110 | 110 | 110 | 110 | 110 | 110 |  |

| <b>CLW 25</b>            |                          | ■ indicates nonusable range |      |     |     |     |     |     |     |  |
|--------------------------|--------------------------|-----------------------------|------|-----|-----|-----|-----|-----|-----|--|
| Hydraulic pressure (MPa) | Allowable eccentricity   |                             |      |     |     |     |     |     |     |  |
|                          | Clamp arm length LH (mm) |                             |      |     |     |     |     |     |     |  |
|                          | 60                       | 65                          | 87.5 | 100 | 120 | 140 | 160 | 180 | 200 |  |
| 35                       | ■                        | ■                           | 21   | 27  | 30  | 34  | 37  | 41  | 44  |  |
| 30                       | ■                        | ■                           | 31   | 46  | 70  | 83  | 97  | 110 | 123 |  |
| 25                       | ■                        | 16                          | 46   | 65  | 95  | 125 | 154 | 160 | 160 |  |
| 20                       | 16                       | 25                          | 68   | 92  | 131 | 160 | 160 | ↑   | ↑   |  |
| 15                       | 32                       | 45                          | 105  | 139 | 160 | ↑   | ↑   | ↑   | ↑   |  |
| 10                       | 65                       | 86                          | 160  | 160 | ↑   | ↑   | ↑   | ↑   | ↑   |  |
| 5                        | 160                      | 160                         | 160  | 160 | 160 | 160 | 160 | 160 | 160 |  |

35MPa clamp & work support  
 Swing clamp  
 Swing clamp (ROEMHELD-compatible)  
 Swing clamp (ENERPAC-compatible)  
 Link clamp  
 Clamp cylinder  
 Work support  
 Option

Standard clamp arm

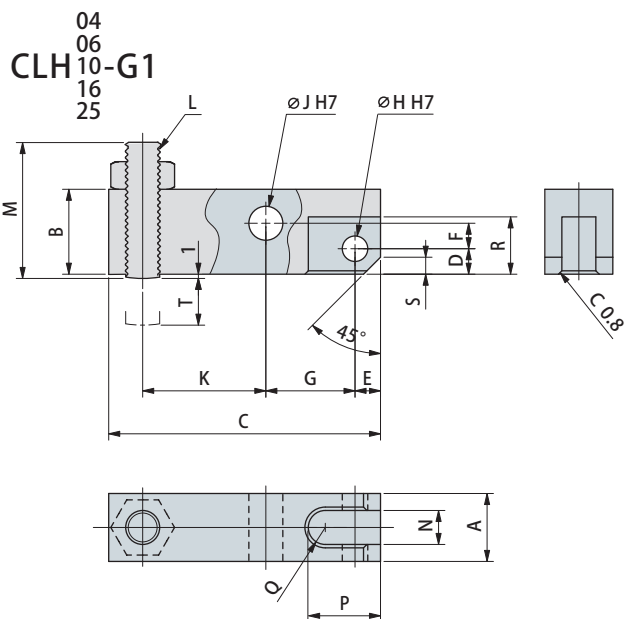

Material: S45C (Refining HB201 ~ 269)

| Clamp arm models      | CLH04-G1                         | CLH06-G1                         | CLH10-G1                          | CLH16-G1                          | CLH25-G1                          |
|-----------------------|----------------------------------|----------------------------------|-----------------------------------|-----------------------------------|-----------------------------------|
| A                     | 12 <sup>0</sup> <sub>-0.1</sub>  | 16 <sup>0</sup> <sub>-0.1</sub>  | 19 <sup>0</sup> <sub>-0.1</sub>   | 22 <sup>0</sup> <sub>-0.1</sub>   | 32 <sup>0</sup> <sub>-0.1</sub>   |
| B                     | 16                               | 20                               | 25                                | 31                                | 38                                |
| C                     | 54                               | 54                               | 73.5                              | 90.5                              | 115.5                             |
| D                     | 6                                | 6                                | 8                                 | 9                                 | 12.5                              |
| E                     | 6                                | 6                                | 7                                 | 10                                | 13                                |
| F                     | 3.5                              | 6                                | 7.5                               | 9.5                               | 9.5                               |
| G                     | 18.5                             | 21                               | 24.5                              | 30.5                              | 37.5                              |
| H                     | 6 <sup>+0.012</sup> <sub>0</sub> | 6 <sup>+0.012</sup> <sub>0</sub> | 8 <sup>+0.015</sup> <sub>0</sub>  | 12 <sup>+0.018</sup> <sub>0</sub> | 14 <sup>+0.018</sup> <sub>0</sub> |
| J                     | 6 <sup>+0.012</sup> <sub>0</sub> | 8 <sup>+0.015</sup> <sub>0</sub> | 10 <sup>+0.015</sup> <sub>0</sub> | 14 <sup>+0.018</sup> <sub>0</sub> | 16 <sup>+0.018</sup> <sub>0</sub> |
| K                     | 23.5                             | 29                               | 32                                | 39                                | 50                                |
| L                     | M6                               | M8                               | M10                               | M12                               | M16                               |
| M                     | 26                               | 32                               | 39                                | 48                                | 58                                |
| N                     | 6 <sup>+0.1</sup> <sub>0</sub>   | 8 <sup>+0.1</sup> <sub>0</sub>   | 10 <sup>+0.1</sup> <sub>0</sub>   | 11 <sup>+0.1</sup> <sub>0</sub>   | 16 <sup>+0.1</sup> <sub>0</sub>   |
| P                     | 14                               | 17                               | 20                                | 26.5                              | 36                                |
| Q                     | R3                               | R4                               | R5                                | R5.5                              | R8                                |
| R                     | 13.5                             | 13.5                             | 17.5                              | 22                                | 28                                |
| S                     | 4                                | 4                                | 5                                 | 7                                 | 8                                 |
| T (adjustment amount) | 9                                | 11                               | 13                                | 16                                | 19                                |
| Arm mass              | 0.10 kg                          | 0.14 kg                          | 0.24 kg                           | 0.41 kg                           | 0.98 kg                           |
| Clamp models          | CLW04                            | CLW06<br>CLV06                   | CLW10<br>CLV10                    | CLW16<br>CLV16                    | CLW25<br>CLV25                    |

Long clamp arm

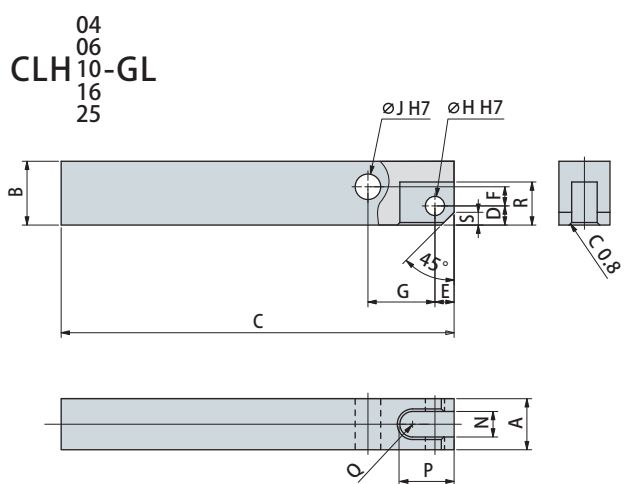

Material: S45C (Refining HB201 ~ 269)

| Clamp arm models | CLH04-GL                         | CLH06-GL                         | CLH10-GL                          | CLH16-GL                          | CLH25-GL                          |
|------------------|----------------------------------|----------------------------------|-----------------------------------|-----------------------------------|-----------------------------------|
| A                | 12 <sup>0</sup> <sub>-0.1</sub>  | 16 <sup>0</sup> <sub>-0.1</sub>  | 19 <sup>0</sup> <sub>-0.1</sub>   | 22 <sup>0</sup> <sub>-0.1</sub>   | 32 <sup>0</sup> <sub>-0.1</sub>   |
| B                | 16                               | 20                               | 25                                | 31                                | 38                                |
| C                | 135                              | 135                              | 180                               | 200                               | 230                               |
| D                | 6                                | 6                                | 8                                 | 9                                 | 12.5                              |
| E                | 6                                | 6                                | 7                                 | 10                                | 13                                |
| F                | 3.5                              | 6                                | 7.5                               | 9.5                               | 9.5                               |
| G                | 18.5                             | 21                               | 24.5                              | 30.5                              | 37.5                              |
| H                | 6 <sup>+0.012</sup> <sub>0</sub> | 6 <sup>+0.012</sup> <sub>0</sub> | 8 <sup>+0.015</sup> <sub>0</sub>  | 12 <sup>+0.018</sup> <sub>0</sub> | 14 <sup>+0.018</sup> <sub>0</sub> |
| J                | 6 <sup>+0.012</sup> <sub>0</sub> | 8 <sup>+0.015</sup> <sub>0</sub> | 10 <sup>+0.015</sup> <sub>0</sub> | 14 <sup>+0.018</sup> <sub>0</sub> | 16 <sup>+0.018</sup> <sub>0</sub> |
| N                | 6 <sup>+0.1</sup> <sub>0</sub>   | 8 <sup>+0.1</sup> <sub>0</sub>   | 10 <sup>+0.1</sup> <sub>0</sub>   | 11 <sup>+0.1</sup> <sub>0</sub>   | 16 <sup>+0.1</sup> <sub>0</sub>   |
| P                | 14                               | 17                               | 20                                | 26.5                              | 36                                |
| Q                | R3                               | R4                               | R5                                | R5.5                              | R8                                |
| R                | 13.5                             | 13.5                             | 17.5                              | 22                                | 28                                |
| S                | 4                                | 4                                | 5                                 | 7                                 | 8                                 |
| Arm mass         | 0.20 kg                          | 0.31 kg                          | 0.62 kg                           | 0.96 kg                           | 1.95 kg                           |
| Clamp models     | CLW04                            | CLW06<br>CLV06                   | CLW10<br>CLV10                    | CLW16<br>CLV16                    | CLW25<br>CLV25                    |

Locknut

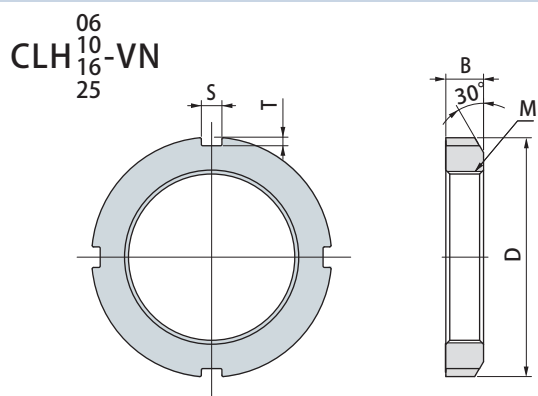

| Locknut models | CLH06-VN       | CLH10-VN       | CLH16-VN       | CLH25-VN       |
|----------------|----------------|----------------|----------------|----------------|
| M              | M45×1.5        | M50×1.5        | M60×2          | M70×2          |
| D              | 65             | 70             | 80             | 92             |
| B              | 10             | 11             | 11             | 12             |
| S              | 6              | 6              | 7              | 8              |
| T              | 2.5            | 2.5            | 3              | 3.5            |
| Clamp models   | CLW06<br>CLV06 | CLW10<br>CLV10 | CLW16<br>CLV16 | CLW25<br>CLV25 |

1. With link clamps, force acting on link mechanism becomes larger as clamp arm becomes shorter. Exceeding maximum allowable load for link mechanism will lead to malfunction. Depending on clamp arm length, it would be necessary to lower clamping force (hydraulic pressure). Use appropriate clamping force that is suitable for clamp arm length, by referring to performance table and performance diagram (refer to **pages → 393 and 394** for CLW series, **pages → 399 and 400** for CLV series).

2. Determine height and mount clamp, ensuring that clamp arm becomes parallel to mounting surface when workpiece is clamped (Allowable angle  $\pm 3^\circ$ ). Adjustment screw at tip section may be used for adjustment when using standard clamp arm.

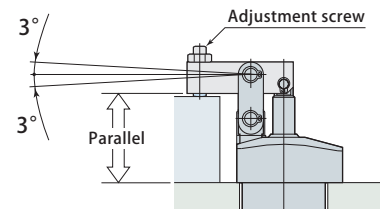
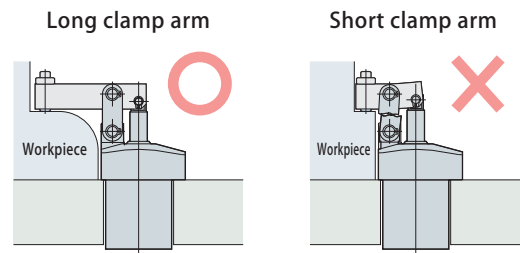

## Mounting of clamp and work support

Use screws with strength class of 12.9 for mounting clamp and work support and be sure to apply specified torque for tightening, by referring to recommended tightening torque of mounting screws indicated below.

Recommended tightening torque of mounting screws (strength class 12.9)

| Mounting screw size | Tightening torque |
|---------------------|-------------------|
| M4 × 0.7            | 2.8 N·m           |
| M5 × 0.8            | 7 N·m             |
| M6 × 1              | 11 N·m            |
| M8 × 1.25           | 25 N·m            |
| M10 × 1.5           | 49 N·m            |
| M12 × 1.75          | 60 N·m            |

## Caution in use of equipment

1. Clamp and work supports have been developed for the purpose of clamping workpiece for machine tools. Do not use them for other purposes.
2. Always protect them with a cover to ensure sliding surfaces are not exposed to weld slags when using them as fixture for welding.
3. Clean sliding surfaces and top part of clamp body with air blowing periodically to ensure smooth operations.

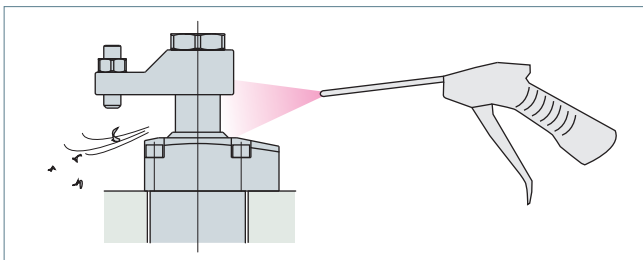

## Mounting & dismounting of optional parts

1. When mounting or dismounting a flow control valve or air bleeding valve, be sure to set pressure within hydraulic circuit to 0 MPa before starting.
2. When mounting a flow control valve or air bleeding valve, be sure to tighten it with the specified tightening torque (refer to pages → 359 and 360 for recommended tightening torque).
3. When mounting a coolant cap (resin : POM), firmly press the body of cover. If it is not mounting properly, use a plastic mallet to tap it into place.
4. When dismounting a coolant cap, use a sharp-pointed tool such as a precision screw driver by hooking the notched portion.

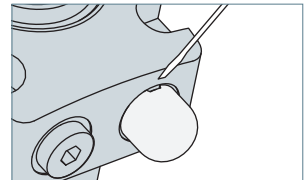

## Caution for hydraulic piping

1. Most problems that occur with hydraulic equipment are caused by foreign substances such as metal chips and dust that enter into hydraulic circuits. Refer to "Piping Hydraulic & Pneumatic Equipment-Practical Notes" provided with the product for mounting and hydraulic piping of the product.
2. After performing hydraulic piping, always be sure to bleed out air in the hydraulic circuit. Insufficient bleeding can lead to malfunction.
3. When using multiple clamps, operating speeds and timings vary due to variance in pipe resistance and internal resistance of clamps. Adjust operating speeds and timings using flow control valve.
4. The special scraper has superior scraping capability to remove oil film on the surface of the rod, there are cases where grease and working fluids (oil films) inside the clamp are scraped and expelled to the outside. This may result in accumulation of oil in the external perimeters of piston rod on the upper part of the scraper, but this does not indicate an oil leak.

## BSPB port sealing method

1. "Sealing method for flange surfaces" has been adopted as standard means for this product. Use fittings and connectors of bonded seal or elastic body seal. Do not use fittings of "Sealing method for tapered surfaces" (O-ring seal method).
2. Seal tapes and liquid packing are not necessary. Seal fittings with included with packing.
3. When mounting, clean metal chips and dust off surfaces that will come into contact with packing.

### Sealing method for flange surfaces

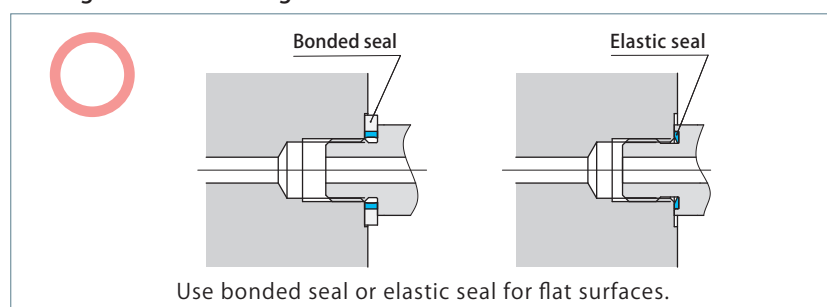

### Sealing method for tapered surfaces

