

**Work support**

model  
**CST**

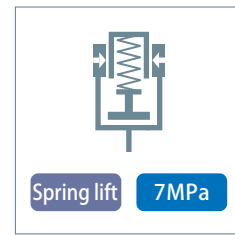

**Taper sleeve type work support with improved reliability**

**Lift spring**

Two types of lift springs are available for selection according to the rigidity of workpiece or weight of head cap. Lift spring can be easily replaced by simply removing head cap.

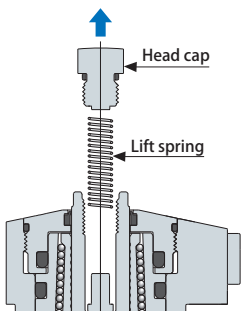

**Coolant countermeasure 1**

Special low friction type scraper that prevents intrusion by high pressure coolant or metal chips, which comprise the biggest problem with work support, has been adopted to ensure smooth plunger stroke operations. Furthermore, stainless materials are used for principal parts other than body, to improve rustproofing and durability of internal parts.

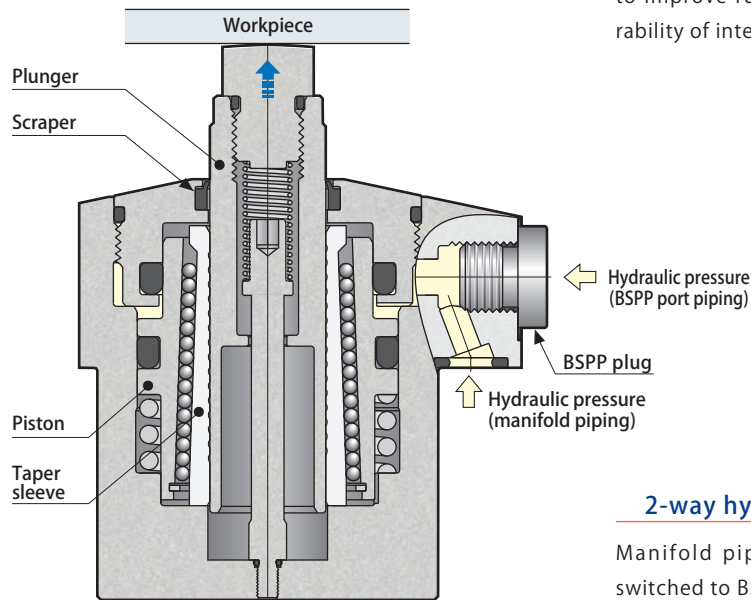

**2-way hydraulic piping**

Manifold piping can easily be switched to BSPP port piping. Refer to page → 122 details on piping methods.

Patented

**Coolant countermeasure 2**

Space between sleeve and plunger can be cleaned by air to prevent intrusion of high pressure coolant or metal chips at the time of workpiece replacement. A dedicated air circuit is required for air cleaning.

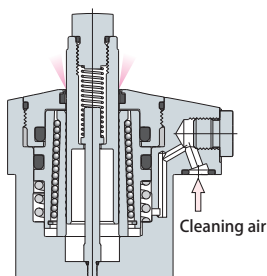

Recommended cleaning air pressure 0.3 ~ 0.5 MPa

7MPa clamp & work support

Swing clamp

Link clamp

Clamp cylinder

Work support

Option

Specifications

Model		CST04	CST06	CST10	CST16	CST25
Support force (hydraulic pressure 7 MPa) *1 (kN)		5	7	10	16	25
Cylinder capacity (cm <sup>3</sup> )		0.7	0.9	1.2	2.1	3.3
Lift spring force *2	L : Standard (N)	3.0 ~ 4.1	4.3 ~ 8.1	5.3 ~ 10.8	5.5 ~ 10.8	6.9 ~ 13.2
	H : Strong (N)	4.8 ~ 7.5	6.6 ~ 11.1	7.8 ~ 13.3	11.2 ~ 19.8	13.5 ~ 22.4
Plunger stroke (mm)		8	12	12	16	16
Max. allowable mass of head cap (kg)		0.15	0.2	0.2	0.3	0.3
Mass (kg)		0.5	0.9	1.1	1.8	3.1

Working pressure range: 2.5 ~ 7 MPa Proof pressure: 10.5 MPa Operating temperature: 0 ~ 70°C  
 Fluid used: General mineral based hydraulic oil (ISO-VG32 equivalent)

\*1 : When work support and clamp are used facing each other, work support and clamp must be selected in such a way that the support force is 1.5 times the applied load (clamping force + machining force).

\*2 : Figures are for "upper end ~ lower end" of plunger action.

Fluorocarbon has been adopted for seal sections where cutting fluid is applied, as a measure for the use of chlorine-based cutting fluid (this is not thermal resistant specification).

Model designation

CST ①-② (Example: CST06-L)

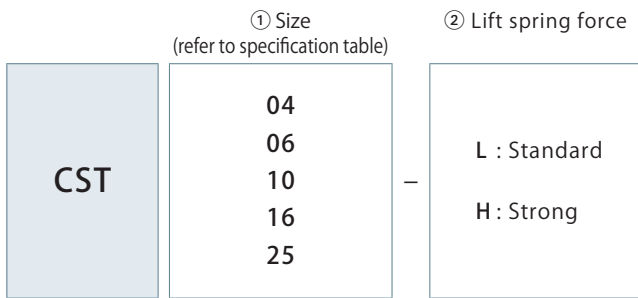

Piping method

Two piping methods are available for work support model CST, manifold piping and BSPP plug piping. Dismount BSPP plug when using BSPP port piping (do not dismount O-ring). Refer to page → 149 for details on BSPP port piping flareless fitting.

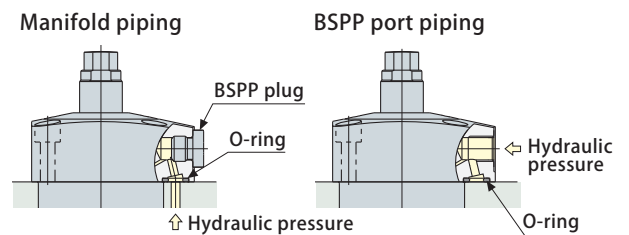

Hydraulic pressure & support force

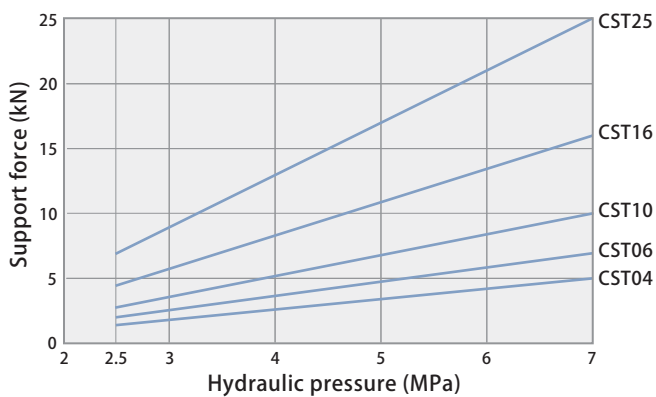

Hydraulic pressure (MPa)	Support force (kN)				
	CST04	CST06	CST10	CST16	CST25
2.5	1.4	2.0	2.8	4.5	7.0
3.0	1.8	2.6	3.6	5.8	9.0
3.5	2.2	3.1	4.4	7.1	11.0
4.0	2.6	3.7	5.2	8.3	13.0
4.5	3.0	4.2	6.0	9.6	15.0
5.0	3.4	4.8	6.8	10.9	17.0
5.5	3.8	5.3	7.6	12.2	19.0
6.0	4.2	5.9	8.4	13.4	21.0
6.5	4.6	6.4	9.2	14.7	23.0
7.0	5.0	7.0	10.0	16.0	25.0

Applied load & deformation

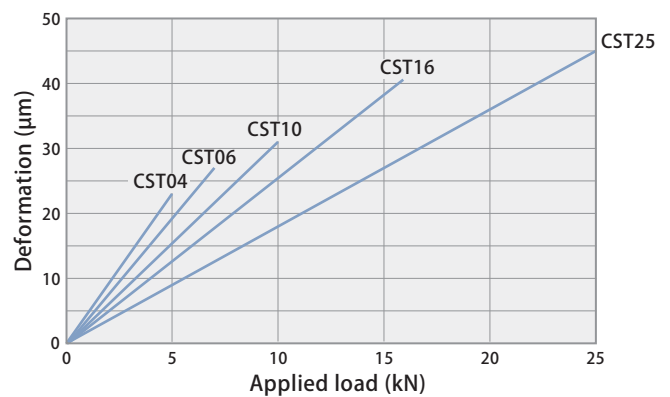

Applied load (kN)	Deformation (µm)				
	CST04	CST06	CST10	CST16	CST25
0	0	0	0	0	0
5	23	19	16	13	9
7		27	22	18	13
10			31	26	18
15				38	27
20					36
25					45

Held with hydraulic pressure of 7 MPa.

Dimensions

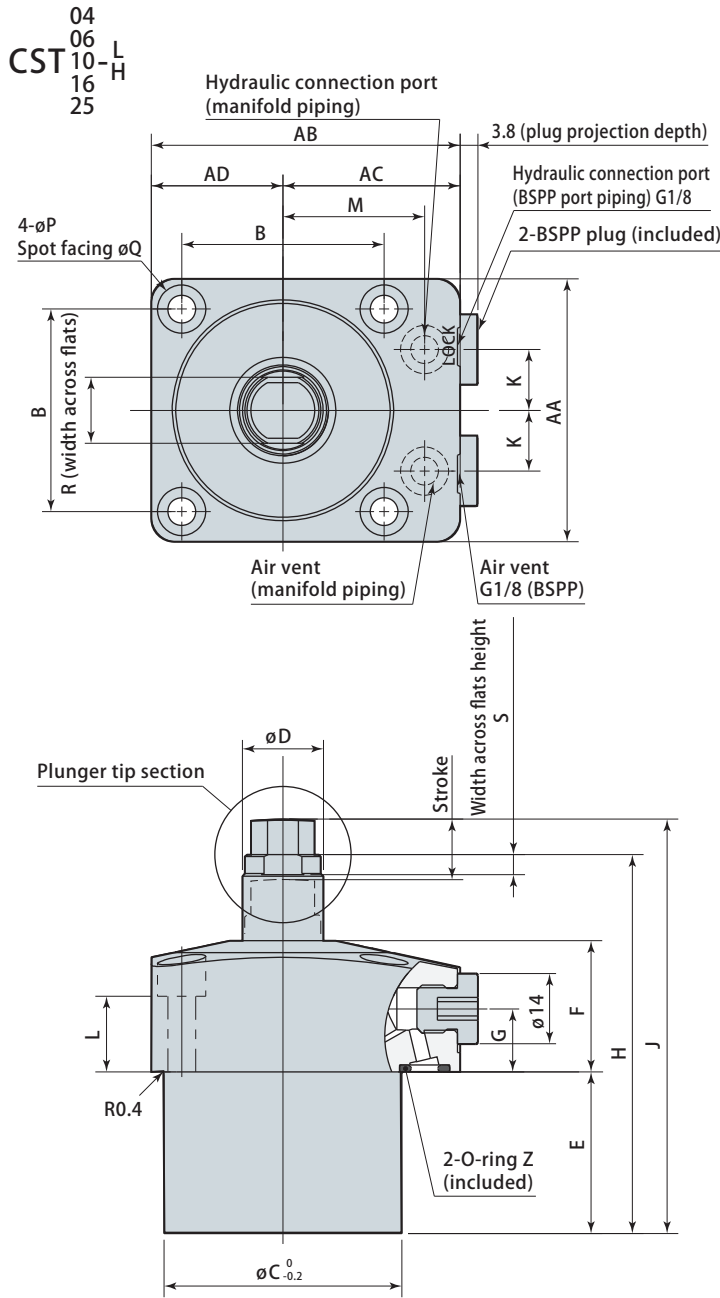

(mm)

Model	CST04- $\frac{L}{H}$	CST06- $\frac{L}{H}$	CST10- $\frac{L}{H}$	CST16- $\frac{L}{H}$	CST25- $\frac{L}{H}$
AA	45	52	56	65	78
AB	55	61	65	73	85
AC	32.5	35	37	40.5	46
AD	22.5	26	28	32.5	39
B	34	40	44	52	62
C	40	47	52	60	72
D	15	16	20	22	25
E	21	32	33	47	67
F	26	26	28	30	30
G	12.5	12.5	12.5	12.5	12.5
H	60	75	78	99	120
J	67	82	85	108	129
K	10	12	13	15	18
L	15	15	16.5	15.9	12
M	25.5	28	30	33.5	39
P	5.5	5.5	5.5	6.8	9
PP	M5	M5	M5	M6	M8
Q	9.5	9.5	9.5	11	14
R	13	13	17	19	22
S	4	4	4.5	5	6
O-ring Z	P7	P7	P7	P7	P7

Material of O-ring Z (included) is fluorocarbon (with hardness Hs90).  
 Note 1. The mounting surface finish must be no rougher than Rz6.3 (ISO4287:1997).

2. Always attach head cap when using (otherwise lift spring cannot be retained).
3. Mounting screws are not included.

Mounting details

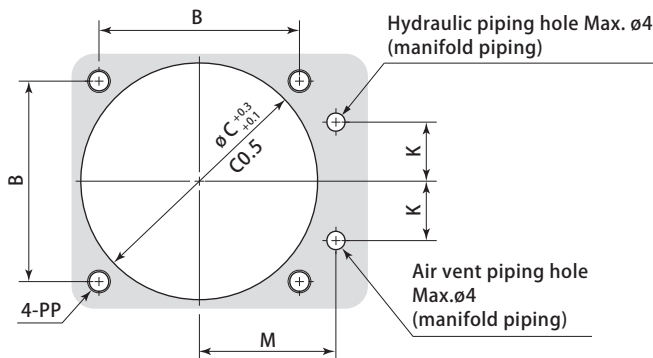

Plunger tip section details

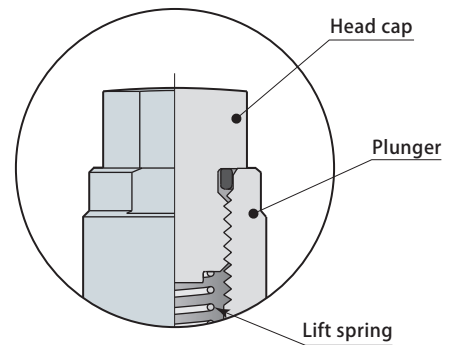

Head cap details

(Hardness: HRC52)

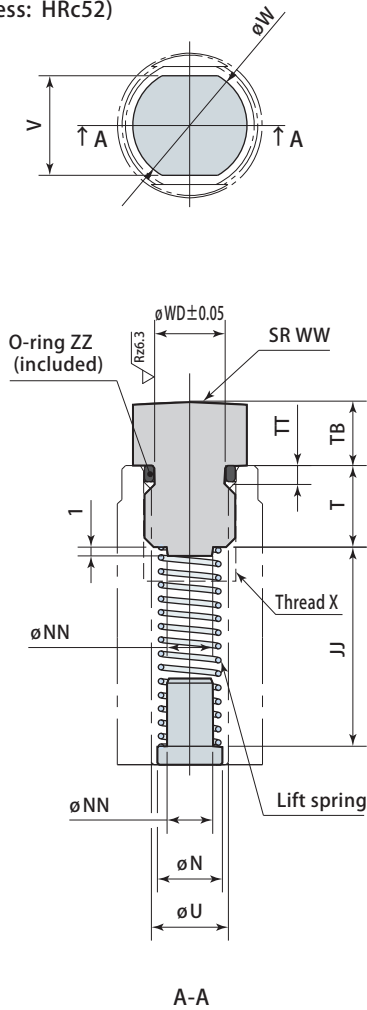

(mm)

Model	CST04- $L_H$	CST06- $L_H$	CST10- $L_H$	CST16- $L_H$	CST25- $L_H$
JJ	17.6	22	22.5	32.5	39
N	7.2	7.2	9.2	9.2	11.2
NN	5	5	6	6	7.5
T	9	9	11	11	15
TB	7	7	7	9	9
TT	1.9	1.9	2.3	2.3	3.5
U	8.5	8.5	10.3	10.3	14
V	11	11	14	14	18
W	12.6	12.6	16.5	16.5	21.5
WD	7.8	7.8	9.2	9.2	13.5
WW	70	70	90	110	140
X nominal size X pitch thread depth (recommended tightening torque)	M10×1.5 depth 11 (30 N·m)	M10×1.5 depth 11 (30 N·m)	M12×1.75 depth 13 (50 N·m)	M12×1.75 depth 13 (50 N·m)	M16×2 depth 20 (80 N·m)
O-ring ZZ	S8	S8	P9	P9	AS568-014

Material of O-ring ZZ (included) is fluorocarbon (with hardness Hs70).

Note 1. When fabricating head cap, ensure that O-ring slot, spring spot facing and guide are made by referring to head cap details. Be sure to always use included O-ring.

2. When fabricating a lift spring, determine dimensions by referring to head cap details. Rustproofing must be implemented (however, there is no guarantee for operation).

3. This diagram indicates a situation where head cap has been fitted into plunger with no pressure applied.

**Caution in use**

1. Air (oil free) must be fed through a 5  $\mu$ m filter that is connected to an air vent connection port for air cleaning. (Recommended cleaning air pressure: 0.3 ~ 0.5 MPa).
2. Air vent must be opened to atmosphere. Provide the piping if there is a risk of coolant or metal chips intrusion.
3. Avoid following usages. These may cause sleeve deformation that could lead to malfunction of plunger or decreased support force.
  - ✗ Applying eccentric load on plunger.
  - ✗ Applying load that exceeds rated support force.
  - ✗ Rotating plunger when locked.

**Hydraulic circuit diagram (reference)**

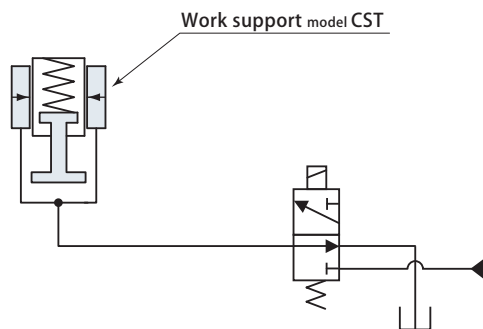

Since plunger is always lifted by the lift spring, speed adjustment by flow control valve is not necessary.

## Mounting of clamp and work support

Use screws with strength class of 12.9 for mounting clamp and work support and be sure to apply specified torque for tightening, by referring to recommended tightening torque of mounting screws indicated below.

Recommended tightening torque of mounting screws (strength class 12.9)

Mounting screws size	Tightening torque
M4 ×0.7	2.8 N·m
M5 ×0.8	7 N·m
M6 ×1	11 N·m
M8 ×1.25	25 N·m
M10×1.5	49 N·m
M12×1.75	60 N·m

## Caution in use of equipment

1. Clamp and work supports have been developed for the purpose of clamping workpiece for machine tools. Do not use them for other purposes.
2. Always protect them with a cover to ensure sliding surfaces are not exposed to weld slags when using them as fixture for welding.
3. Clean sliding surfaces and top part of clamp body with air blowing periodically to ensure smooth operations.

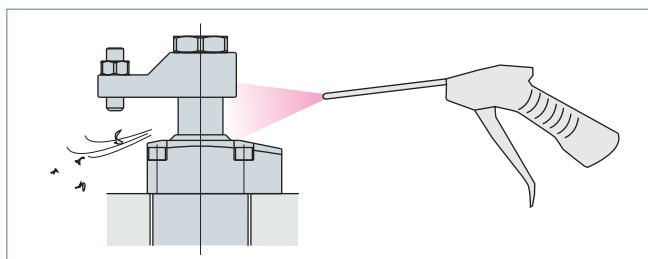

## Mounting & dismantling of optional parts

1. When mounting or dismantling a flow control valve or air bleeding valve, be sure to set pressure within hydraulic circuit to 0 MPa before starting.
2. When mounting a flow control valve or air bleeding valve, be sure to tighten it with the specified tightening torque (refer to pages → 145 and 146 for recommended tightening torque).
3. When mounting a coolant cap (resin : POM), firmly press the body of cover. If it is not mounting properly, use a plastic mallet to tap it into place.
4. When dismantling a coolant cap, use a sharp-pointed tool such as a precision screw driver by hooking the notched portion.

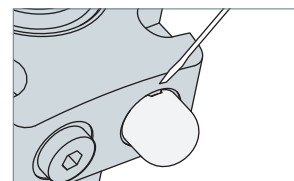

## Caution for hydraulic piping

1. Most problems that occur with hydraulic equipment are caused by foreign substances such as metal chips and dust that enter into hydraulic circuits. Refer to "Piping Hydraulic & Pneumatic Equipment-Practical Notes" provided with the product for mounting and hydraulic piping of the product.
2. After performing hydraulic piping, always be sure to bleed out air in the hydraulic circuit. Insufficient bleeding can lead to malfunction.
3. When using multiple clamps, operating speeds and timings vary due to variance in pipe resistance and internal resistance of clamps. Adjust operating speeds and timings using flow control valve.
4. The special scraper has superior scraping capability to remove oil film on the surface of the rod, there are cases where grease and working fluid (oil films) inside the clamp are scraped and expelled to the outside. This may result in accumulation of oil in the external perimeters of piston rod on the upper part of the scraper, but this does not indicate an oil leak.

## BSPB port sealing method

1. "Sealing method for flange surfaces" has been adopted as standard means for this product. Use fittings and connectors of bonded seal or elastic body seal. Do not use fittings of "Sealing method for tapered surfaces" (O-ring seal method).
2. Seal tapes and liquid packing are not necessary. Seal fittings with included with packing.
3. When mounting, clean metal chips and dust off surfaces that will come into contact with packing.

### Sealing method for flange surfaces

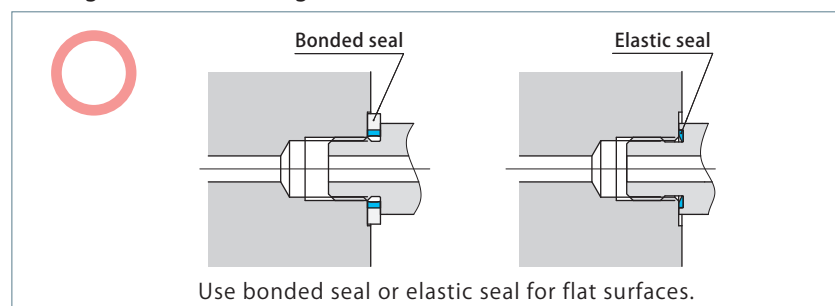

### Sealing method for tapered surfaces

