

**Work support**

model  
**CSV**

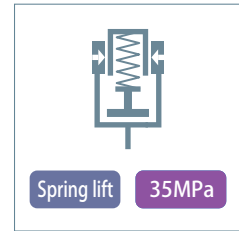

ROEMHELD-compatible model

**Superior support force and perfect coolant countermeasure**

**Chip cover**

Protecting the scraper from chips which become hot due to dry cutting.

**Lift spring**

Lift spring can be easily replaced by simply removing head cap. Change lift springs according to the rigidity of workpiece or weight of head cap.

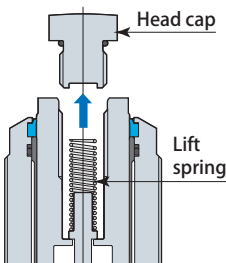

For fabrication of special head cap, refer to detail description about the head cap on page → 422.

**ROEMHELD-compatible model**

To ensure the size compatibility with the ROEMHELD work support, long body models and spacers are available. Inquire for details.

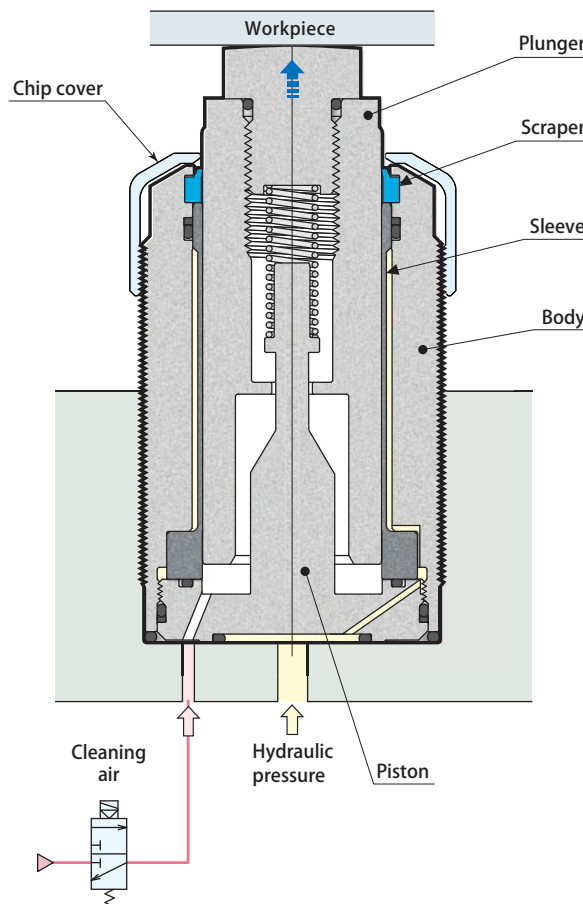

**Coolant countermeasure 1**

Stainless materials are used for principal parts other than body, to improve rustproofing and durability of internal parts.

**Fluorocarbon seal**

Fluorocarbon (Viton) seal has been adopted for scrapers and seal sections as a measure for the use of chlorine-based cutting fluid.

Patented  
**Coolant countermeasure 2**

Space between sleeve and plunger can be cleaned by air to prevent intrusion of high pressure coolant or metal chips at the time of workpiece replacement. A dedicated air circuit is required for air cleaning.

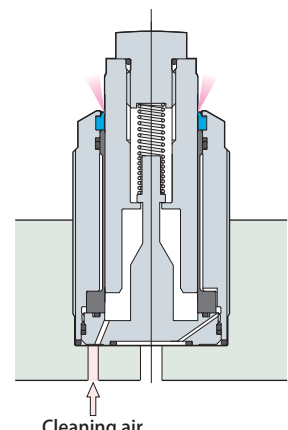

Recommended cleaning air pressure  
0.3 ~ 0.5 MPa

35MPa clamp & work support

Swing clamp

Swing clamp (ROEMHELD-compatible)

Swing clamp (ENERPAC-compatible)

Link clamp

Clamp cylinder

Work support

Option

**Model**

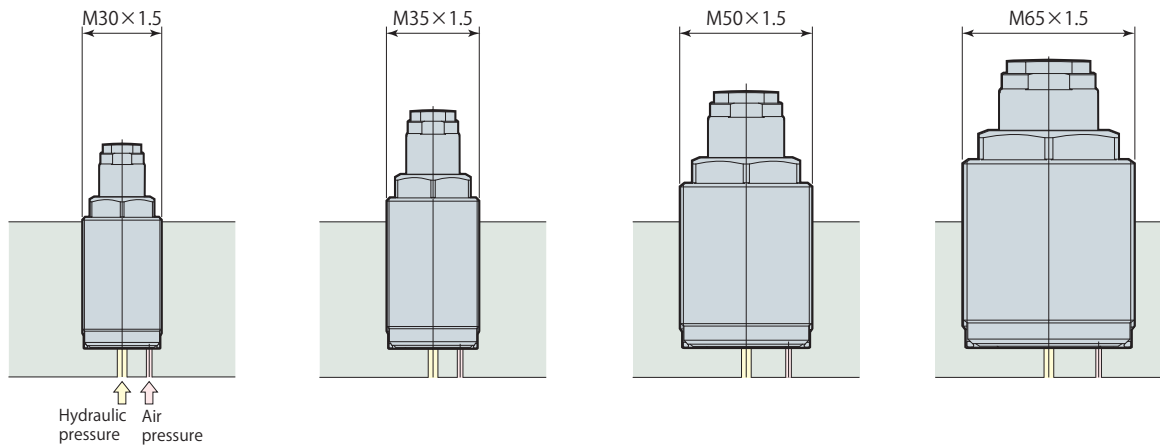

Model	CSV06M-L	CSV10M-L	CSV16M-L	CSV25M-L
Stroke	8 mm	10 mm	10 mm	13 mm
Support force	7.1 kN	11.1 kN	17.8 kN	26.7 kN

**Option**

**Flange**



**Piping cap, locknut**



**Chip cover**

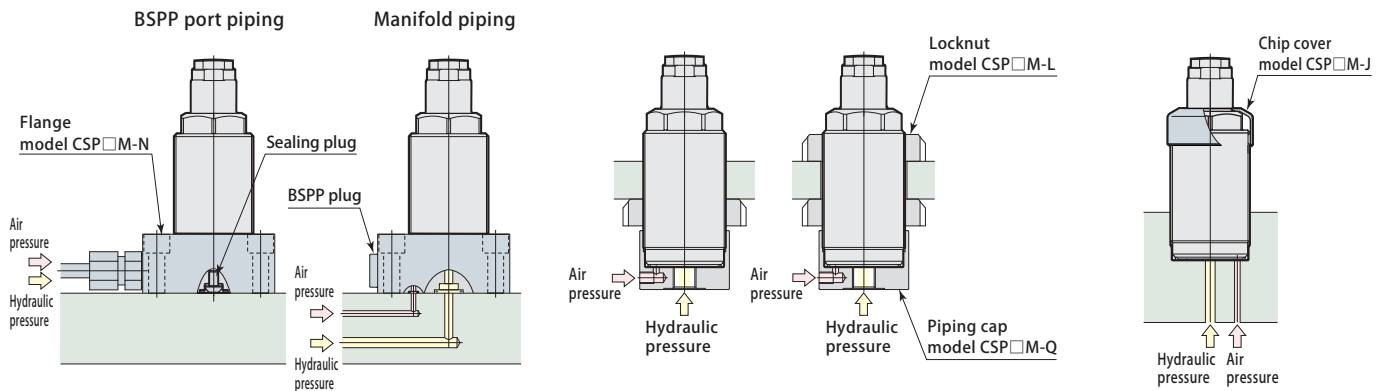

Flange is available for BSP port piping and manifold piping.

Refer to pages → 423 and 424 for details on mounting of optional parts, pages → 425 and 426 for detailed dimensions.

35MPa clamp & work support  
 Swing clamp  
 Swing clamp (ROEMHELD-compatible)  
 Swing clamp (ENERPAC-compatible)  
 Link clamp  
 Clamp cylinder  
 Work support  
 Option

Specifications

Model		CSV06M-L	CSV10M-L	CSV16M-L	CSV25M-L
Support force *1	Hydraulic pressure 35 MPa (kN)	7.1	11.1	17.8	26.7
	Hydraulic pressure 25 MPa (kN)	4.7	7.4	11.9	17.8
	Hydraulic pressure 15 MPa (kN)	2.3	3.7	6.0	8.9
Plunger stroke	(mm)	8	10	10	13
Cylinder capacity	(cm <sup>3</sup> )	1.5	2.9	5.5	5.7
Lift spring force (from upper end to lower end)	(N)	6 ~ 11	10 ~ 16	16 ~ 29	25 ~ 45
Max. allowable mass of head cap	(kg)	0.1	0.1	0.2	0.2
Mass	(kg)	0.28	0.42	1.02	1.90

Working pressure range: 10 ~ 35 MPa Proof pressure: 52.5 MPa Operating temperature: 0 ~ 70°C

Fluid used: General mineral based hydraulic oil (ISO-VG32 equivalent)

\*1 : When work support and clamp are used facing each other, work support and clamp must be selected in such a way that the support force is 1.5 times the applied load (clamping force + machining force).

Fluorocarbon has been adopted for seal sections where cutting fluid is applied, as a measure for the use of chlorine-based cutting fluid (this is not thermal resistant specification).

Model designation

CSV<sup>①</sup>M-L (Example: CSV06M-L)

① Size (refer to specification table)

② Plunger stroke

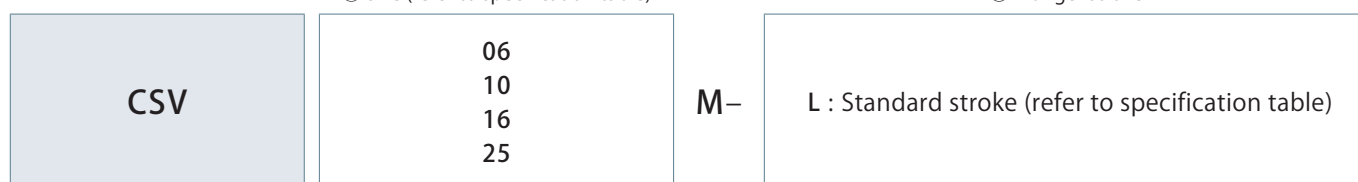

Hydraulic pressure & support force

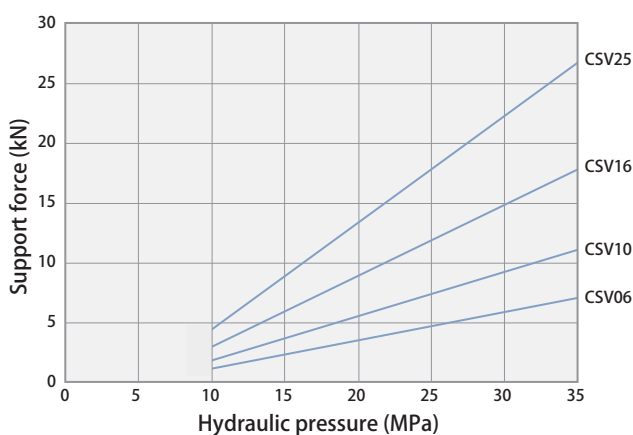

Hydraulic pressure (MPa)	Support force (kN)			
	CSV06	CSV10	CSV16	CSV25
10	1.2	1.9	3.0	4.5
15	2.3	3.7	6.0	8.9
20	3.5	5.6	8.9	13.4
25	4.7	7.4	11.9	17.8
30	5.9	9.3	14.8	22.3
35	7.1	11.1	17.8	26.7

Applied load & deformation

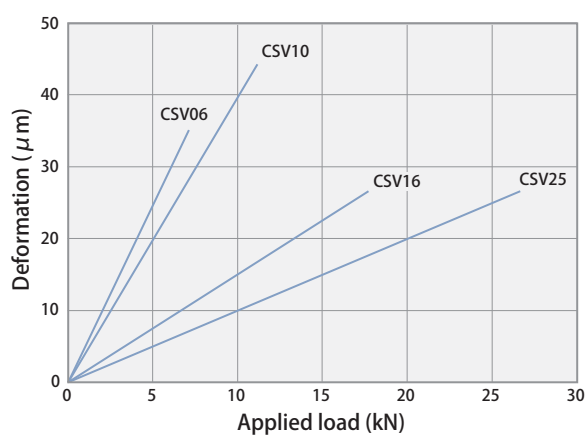

Applied load (kN)	Deformation (μm)			
	CSV06	CSV10	CSV16	CSV25
0	0	0	0	0
5	25	20	7.5	5
10		40	15	10
15			22.5	15
20				20
25				25
30				

Held with hydraulic pressure of 35 MPa.

**Dimensions**

06  
10  
16  
25  
**CSV M-L**

(mm)

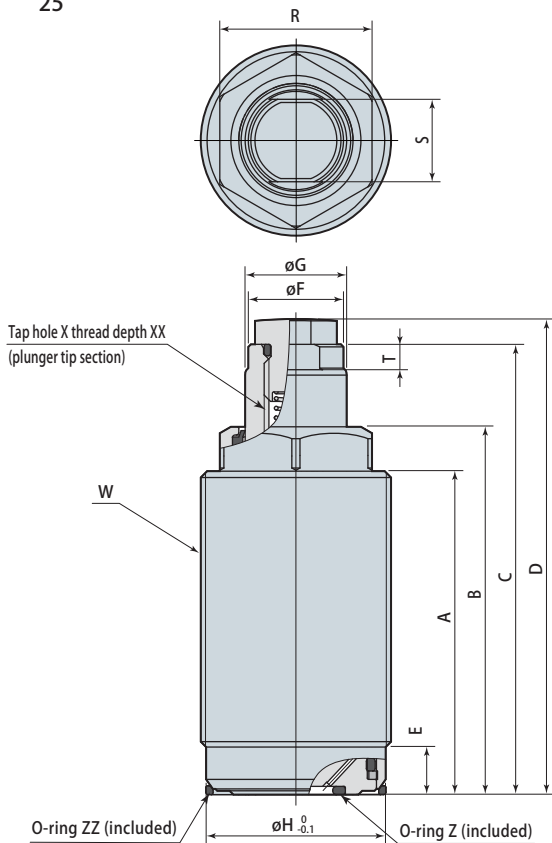

Mounting details

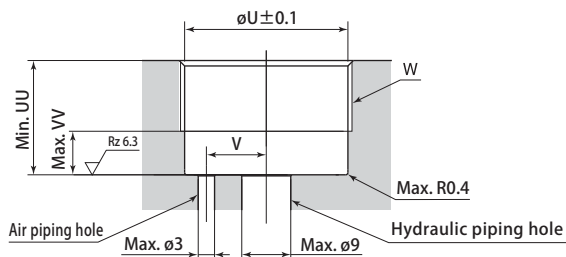

Head cap details

(Hardness: HRC52)

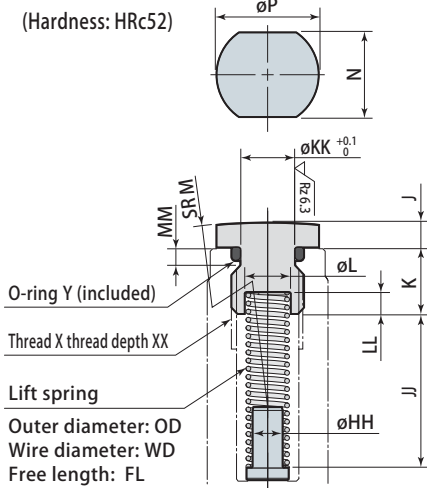

Model	CSV06M-L	CSV10M-L	CSV16M-L	CSV25M-L
A	51	58	59.5	68.5
B	58	67	71.8	82
C	71	83	88	102
D	75	87	94	109
E	7.5	7.5	7.5	8
F	15	19	29	39
G	16	20	30	40
H	28.3	33.2	48.2	63.2
HH	5	5	6	7.5
J	4	4	6	7
JJ	20.5	25.5	25	32.5
K	9	11	12	11
KK	7.8	8.9	13.3	13.3
L	7.4	7.6	9.2	11.2
LL	1.5	3.5	1.5	1.5
M	70	90	110	140
MM	1.9	3	2.4	2.4
N	12	14	19	24
P	12.9	16.9	23	30
R	24	30	41	55
S	13	17	24	32
T	4	5	5	5.7
U	28.5	33.5	48.5	63.5
UU	15.5	15.5	15.5	20
V	11	12	18	23.5
VV	6.5	6.5	6.5	7
W	M30×1.5	M35×1.5	M50×1.5	M65×1.5
X	M10×1.5	M12×1.75	M16×2	M16×2
XX	13	16	20	20
Y *1	S8	P9	AS568-014	AS568-014
Z *2	AS568-014	AS568-015	AS568-019	AS568-022
ZZ *2	AS568-022	AS568-025	S45	AS568-036
OD	6.8	7	8.6	10.7
WD	0.6	0.7	0.9	1.2
FL	41.6	49.3	47.8	51.7
Body tightening torque	35 N·m	60 N·m	130 N·m	250 N·m
Head cap tightening torque	30 N·m	50 N·m	100 N·m	100 N·m

\*1: Material used for O-ring is fluorocarbon (with hardness Hs70).

\*2: Material used for O-ring is fluorocarbon (with hardness Hs90).

Note 1. Remember to use the air piping for air cleaning. Air piping must be opened to atmosphere when not used for air cleaning.

When the air piping is found exposed to entry of cutting fluid or chips, extend the piping to a place free from entry using an air tube, etc.

2. The thread W is also available in the unified screw thread specification. Inquire for details.

**Flange mounting dimensions**

(mm)

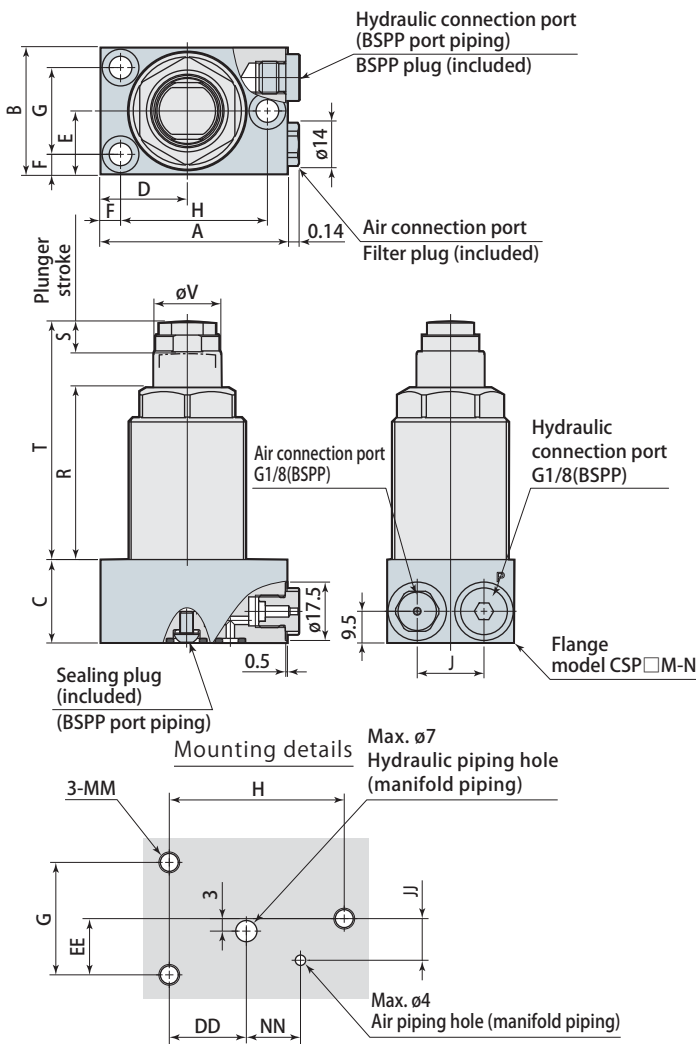

Model	CSV06M-L	CSV10M-L	CSV16M-L	CSV25M-L
A	49	56	66.5	83.5
B	38	38	60	75
C	25	25	25	30
D	21	26	29	36
E	19	19	30	37.5
F	5	6	6	8
G	28	26	48	59
H	37.5	44	54.5	68
J	20	20	24	30
R	42.5	51.5	56.3	62
S	8	10	10	13
T	59.5	71.5	78.5	89
V	16	20	30	40
DD	16	20	23	28
EE	14	13	24	29.5
JJ	10	10	12	15
MM	M5	M6	M6	M8
NN	12	13	15.5	22.5
Flange models	CSP06M-N	CSP10M-N	CSP16M-N	CSP25M-N

- Note 1. The mounting surface finish must be no rougher than Rz 6.3 (ISO4287:1997) for manifold piping.
- Remove the plug of connection port to be used when mounting.
  - Mounting screws are not included.
  - Refer to page → 425 for details on flanges.
  - If the air connection port is directly subjected to the coolant, extend the piping to a location that is not subjected to the coolant and make the air connection port open to atmosphere.

**Locknut, piping cap mounting dimensions**

(mm)

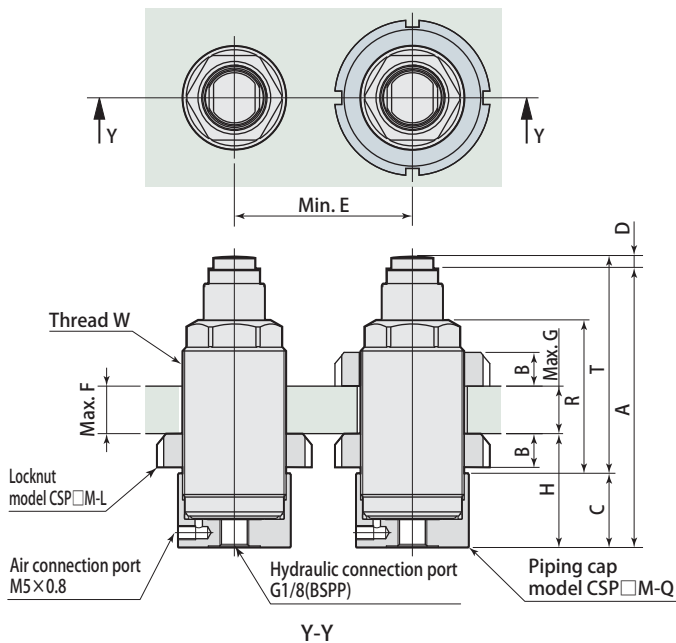

Model	CSV06M-L	CSV10M-L	CSV16M-L	CSV25M-L
A	80.5	92.5	97.5	111.5
B	7	8	11	12
C	25	25	25	28.5
D	4	4	6	7
E	46	53	71	86
F	26.5	32.5	30.9	35
G	19.5	24.5	19.9	23
H	33	34	37	41.5
R	42.5	51.5	56.3	63
T	59.5	71.5	78.5	90
W	M30×1.5	M35×1.5	M50×1.5	M65×1.5
Locknut models	CSP06M-L	CSP10M-L	CSP16M-L	CSP25M-L
Piping cap models	CSP06M-Q	CSP10M-Q	CSP16M-Q	CSP25M-Q

- Note 1. Refer to page → 426 for details on locknuts and piping caps.

Chip cover mounting dimensions

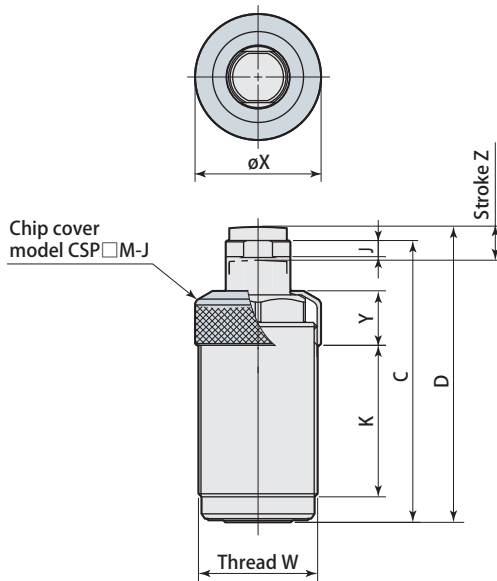

(mm)

Model	CSV06M-L	CSV10M-L	CSV16M-L	CSV25M-L
C	71	83	88	102
D	75	87	94	109
J	4	5	5.2	6
K	37.5	44.5	45.3	54
W	M30×1.5	M35×1.5	M50×1.5	M65×1.5
X	32	37	52	68
Y	14	16	20	21
Z	8	10	10	13
Chip cover models	CSP06M-J	CSP10M-J	CSP16M-J	CSP25M-J

Note 1. Refer to page → 426 for details on chip covers.

**⚠ Caution in use**

- Avoid following usages. These may cause sleeve deformation that could lead to malfunction of plunger or decreased support force.
  - ✗ Applying eccentric load on plunger.
  - ✗ Applying load that exceeds rated support force.
  - ✗ Rotating plunger when locked.
- Air (oil free) must be fed through a 5 mm filter that is connected to an air vent connection port for air cleaning. (recommended cleaning air pressure: 0.3~0.5 MPa). Perform air cleaning only when replacing workpiece. Plunger will rise during air cleaning.

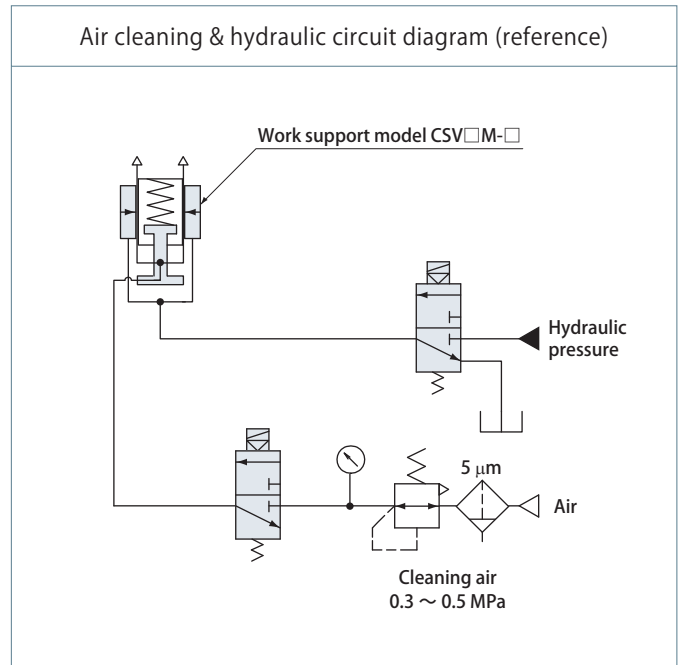

Model designation

**CSP**①**M-**② (Example: CSP06M-N)

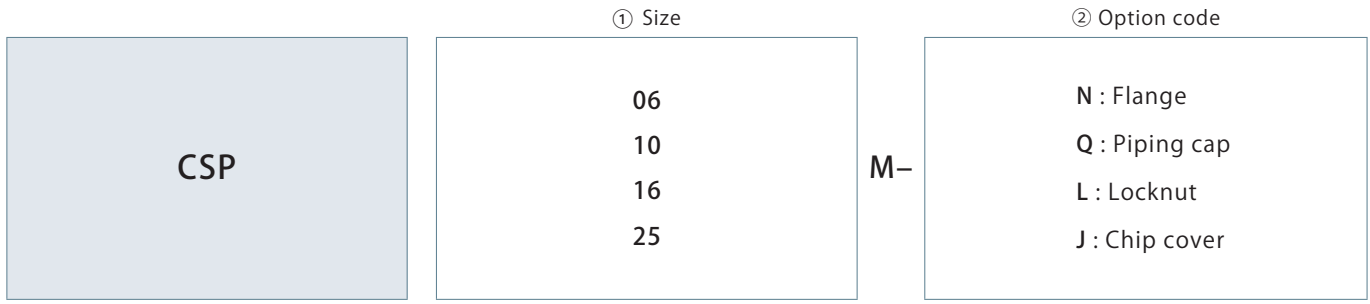

35MPa clamp & work support

Swing clamp

Swing clamp (ROHMHELD-compatible)

Swing clamp (ENERPAC-compatible)

Link clamp

Clamp cylinder

Work support

Option

Flange

**CSP**①**M-N**  
06  
10  
16  
25

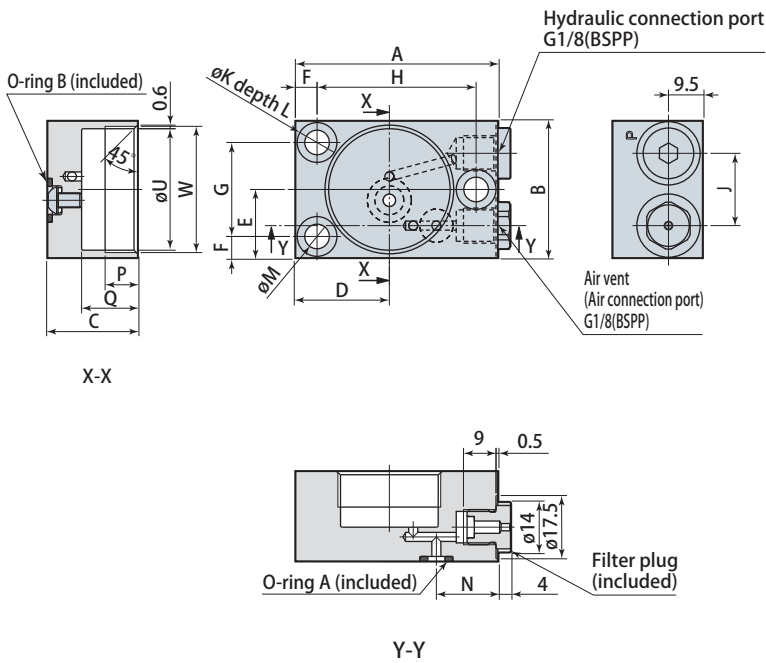

(mm)

Flange models	CSP06M-N	CSP10M-N	CSP16M-N	CSP25M-N
A	49	56	66.5	83.5
B	38	38	60	75
C	25	25	25	30
D	21	26	29	36
E	19	19	30	37.5
F	5	6	6	8
G	28	26	48	59
H	37.5	44	54.5	68
J	20	20	24	30
K	9.5	11	11	14
L	6.5	8	8	11
M	5.5	6.8	6.8	8.5
N	16	17	22	25
P	9	9	9	12
Q	15.5	15.5	15.5	20
U	28.5	33.5	48.5	63.5
W	M30×1.5	M35×1.5	M50×1.5	M65×1.5
O-ring A*1	P6	P6	P6	P6
O-ring B*2	P9	P9	P9	P9
Work support models	CSW06M CSV06M	CSW10M CSV10M	CSW16M CSV16M	CSW25M CSV25M

\*1: Material used for O-ring is fluorocarbon (with hardness Hs70).  
 \*2: Material used for O-ring is fluorocarbon (with hardness Hs90).

**Piping cap**

CSP<sup>06</sup><sub>10</sub><sup>16</sup><sub>25</sub>M-Q

(mm)

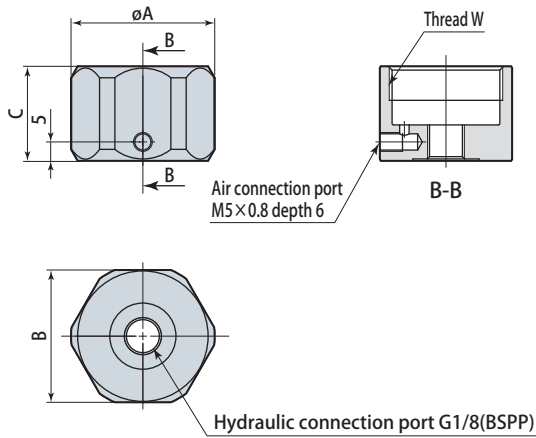

Piping cap models	CSP06M-Q	CSP10M-Q	CSP16M-Q	CSP25M-Q
A	38	41	60	76
B	35	38	55	70
C	25	25	25	28.5
S	8	10	10	13
W	M30×1.5	M35×1.5	M50×1.5	M65×1.5
Work support models	CSW06M CSV06M	CSW10M CSV10M	CSW16M CSV16M	CSW25M CSV25M

**Locknut**

CSP<sup>06</sup><sub>10</sub><sup>16</sup><sub>25</sub>M-L

(mm)

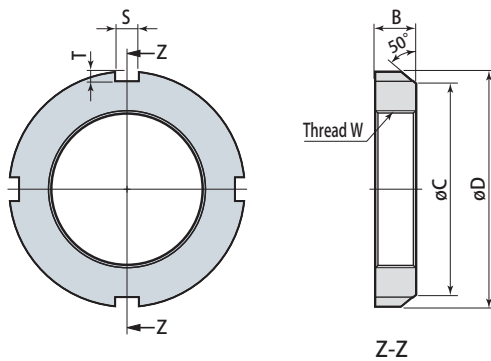

Locknut models	CSP06M-L	CSP10M-L	CSP16M-L	CSP25M-L
B	7	8	11	12
C	38	44	61	79
D	45	52	70	85
S	5	5	6	7
T	2	2	2.5	3
W	M30×1.5	M35×1.5	M50×1.5	M65×1.5
Work support models	CSW06M CSV06M	CSW10M CSV10M	CSW16M CSV16M	CSW25M CSV25M

**Chip cover**

CSP<sup>06</sup><sub>10</sub><sup>16</sup><sub>25</sub>M-J

(mm)

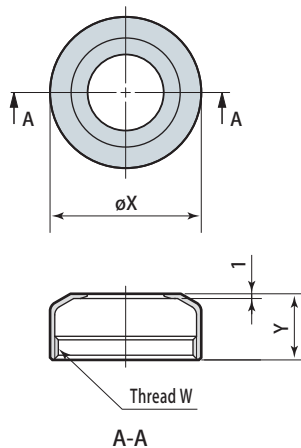

Chip cover models	CSP06M-J	CSP10M-J	CSP16M-J	CSP25M-J
W	M30×1.5	M35×1.5	M50×1.5	M65×1.5
X	32	37	52	68
Y	14	16	20	21
Work support models	CSW06M CSV06M	CSW10M CSV10M	CSW16M CSV16M	CSW25M CSV25M

## Mounting of clamp and work support

Use screws with strength class of 12.9 for mounting clamp and work support and be sure to apply specified torque for tightening, by referring to recommended tightening torque of mounting screws indicated below.

Recommended tightening torque of mounting screws (strength class 12.9)

Mounting screw size	Tightening torque
M4 × 0.7	2.8 N·m
M5 × 0.8	7 N·m
M6 × 1	11 N·m
M8 × 1.25	25 N·m
M10 × 1.5	49 N·m
M12 × 1.75	60 N·m

## Caution in use of equipment

1. Clamp and work supports have been developed for the purpose of clamping workpiece for machine tools. Do not use them for other purposes.
2. Always protect them with a cover to ensure sliding surfaces are not exposed to weld slags when using them as fixture for welding.
3. Clean sliding surfaces and top part of clamp body with air blowing periodically to ensure smooth operations.

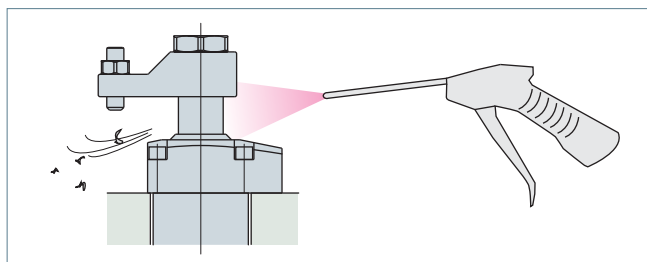

## Mounting & dismounting of optional parts

1. When mounting or dismounting a flow control valve or air bleeding valve, be sure to set pressure within hydraulic circuit to 0 MPa before starting.
2. When mounting a flow control valve or air bleeding valve, be sure to tighten it with the specified tightening torque (refer to pages → 359 and 360 for recommended tightening torque).
3. When mounting a coolant cap (resin : POM), firmly press the body of cover. If it is not mounting properly, use a plastic mallet to tap it into place.
4. When dismounting a coolant cap, use a sharp-pointed tool such as a precision screw driver by hooking the notched portion.

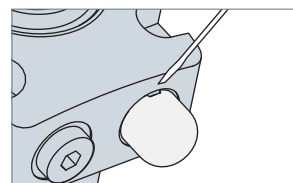

## Caution for hydraulic piping

1. Most problems that occur with hydraulic equipment are caused by foreign substances such as metal chips and dust that enter into hydraulic circuits. Refer to "Piping Hydraulic & Pneumatic Equipment-Practical Notes" provided with the product for mounting and hydraulic piping of the product.
2. After performing hydraulic piping, always be sure to bleed out air in the hydraulic circuit. Insufficient bleeding can lead to malfunction.
3. When using multiple clamps, operating speeds and timings vary due to variance in pipe resistance and internal resistance of clamps. Adjust operating speeds and timings using flow control valve.
4. The special scraper has superior scraping capability to remove oil film on the surface of the rod, there are cases where grease and working fluids (oil films) inside the clamp are scraped and expelled to the outside. This may result in accumulation of oil in the external perimeters of piston rod on the upper part of the scraper, but this does not indicate an oil leak.

## BSPB port sealing method

1. "Sealing method for flange surfaces" has been adopted as standard means for this product. Use fittings and connectors of bonded seal or elastic body seal. Do not use fittings of "Sealing method for tapered surfaces" (O-ring seal method).
2. Seal tapes and liquid packing are not necessary. Seal fittings with included with packing.
3. When mounting, clean metal chips and dust off surfaces that will come into contact with packing.

### Sealing method for flange surfaces

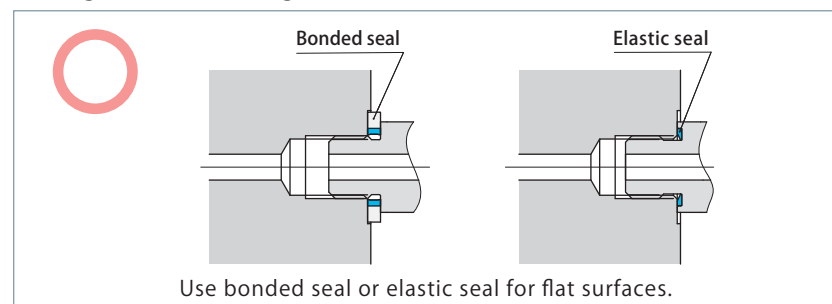

### Sealing method for tapered surfaces

