

Air clamp & work support

Swing clamp

Link clamp

Option

Work support

air  
Work support  
model  
**CSX**

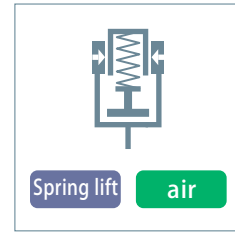

### Taper sleeve type work support with improved reliability

#### Lift spring

Two types of lift springs are available for selection according to the rigidity of workpiece or weight of head cap. Lift spring can be easily replaced by simply removing head cap.

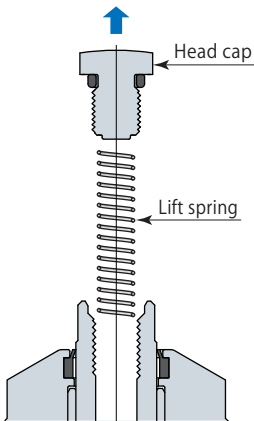

#### Compact & light weight

This is a threaded type compact air driven work support. Effective for space saving on fixture pallets and weight reductions.

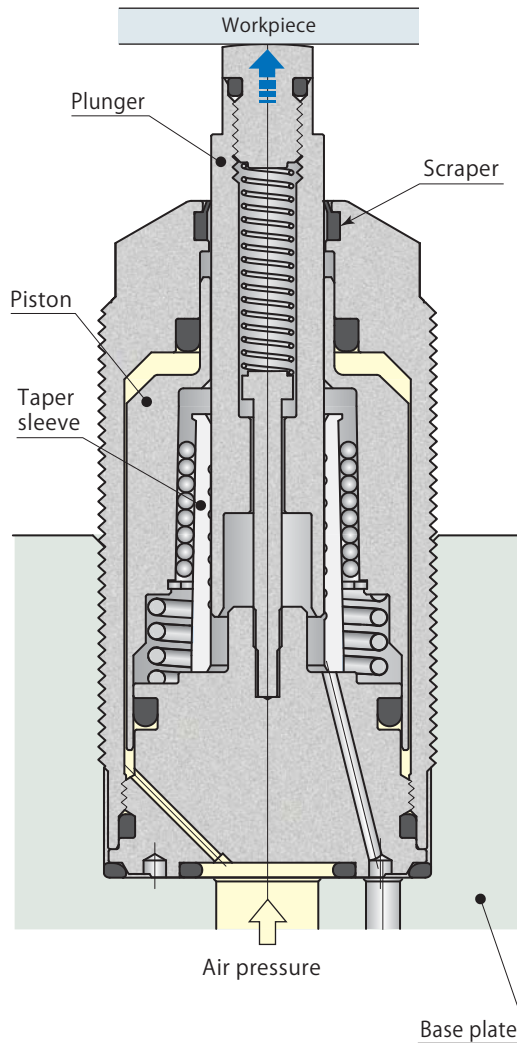

#### Coolant countermeasure 1

Special low friction type scraper that prevents intrusion by high pressure coolant or metal chips, which comprise the biggest problem with work support, has been adopted to ensure smooth plunger stroke operations. Furthermore, stainless materials are used for principal parts other than body, to improve rustproofing and durability of internal parts.

#### Patented Coolant countermeasure 2

Space between sleeve and plunger can be cleaned by air to prevent intrusion of high pressure coolant or metal chips at the time of workpiece replacement. A dedicated air circuit is required for air cleaning.

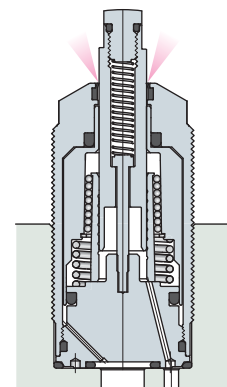

Recommended cleaning air pressure  
0.3 ~ 0.5 MPa

Specifications

Model		CSX00	CSX01	CSX02	CSX04	CSX05
Support force	air pressure 1 MPa *1 (kN)	0.8	1.3	1.9	3.5	5.0
	air pressure 0.5 MPa (kN)	0.3	0.5	0.7	1.3	1.9
Cylinder capacity (cm <sup>3</sup> )		0.8	1.3	2.2	3.6	4.6
Lift spring force *2	L: Standard (N)	1 ~ 2	1 ~ 2	1 ~ 2	2 ~ 4	4 ~ 7
	H: Strong (N)	2 ~ 3	2 ~ 3	2 ~ 3	3 ~ 6	6 ~ 11
Plunger stroke (mm)		6.5	6.5	8.0	8.0	8.0
Max. allowable mass of head cap (kg)		0.05				
Mass (kg)		0.2	0.3	0.4	0.8	1.1

Working air pressure range: 0.4 ~ 1 MPa    Proof pressure: 1.5 MPa    Operating temperature: 0 ~ 70°C

\*1: When work support and clamp are used facing each other, work support and clamp must be selected in such a way that the support force is 1.5 times the applied load (clamping force + machining force).

\*2: Figures are for "upper end ~ lower end" of plunger action.

Fluid used is air that has been processed through a 5 μm filter.

Fluorocarbon has been adopted for seal sections where cutting fluid is applied, as a measure for the use of chlorine-based cutting fluid (this is not thermal resistant specification.)

Air sensor operation is unavailable.

Model designation

CSX ①-② (Example : CSX02-L)

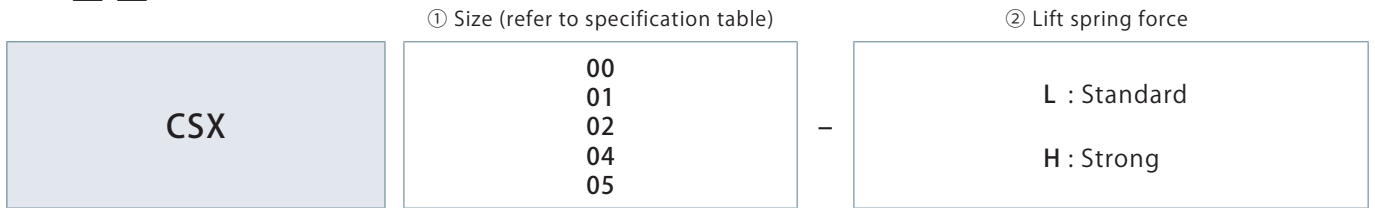

Air pressure & support force

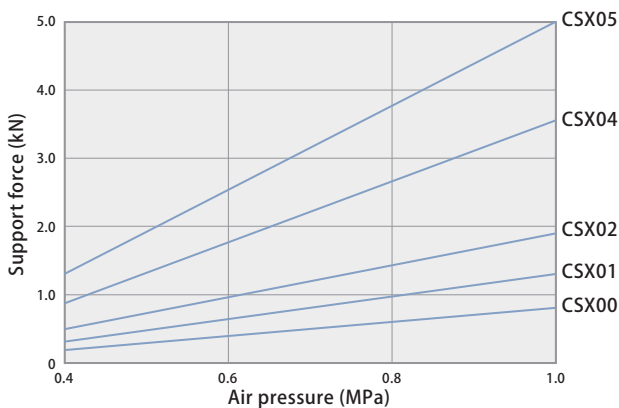

Air pressure (MPa)	Support force (kN)				
	CSX00	CSX01	CSX02	CSX04	CSX05
0.4	0.2	0.3	0.5	0.9	1.3
0.5	0.3	0.5	0.7	1.3	1.9
0.6	0.4	0.7	1.0	1.7	2.5
0.7	0.5	0.8	1.2	2.2	3.1
0.8	0.6	1.0	1.4	2.6	3.8
0.9	0.7	1.1	1.7	3.1	4.4
1.0	0.8	1.3	1.9	3.5	5.0

Applied load & deformation

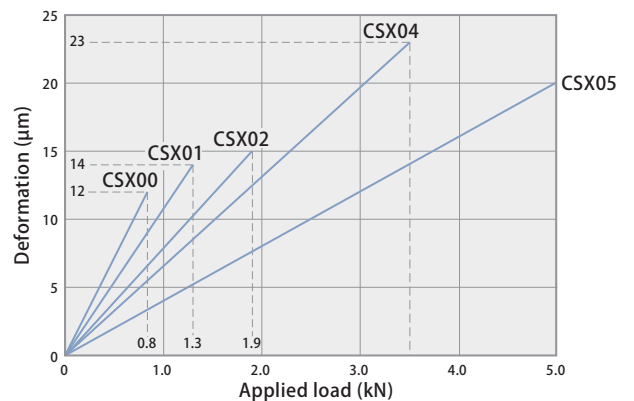

Applied load (kN)	Deformation (μm)				
	CSX00	CSX01	CSX02	CSX04	CSX05
0	0.0	0.0	0.0	0.0	0.0
0.5	7.5	5.4	3.9	3.3	2.0
1.0	14	10.8	7.9	6.6	4.0
1.5	21	16.2	11.8	9.9	6.0
2.0	28	21.6	15.8	13.1	8.0
2.5	35	27.0	19.7	16.4	10.0
3.0	42	32.4	23.6	19.7	12.0
3.5	49	37.8	27.5	23.0	14.0
4.0	56	43.2	31.4	26.3	16.0
4.5	63	48.6	35.3	29.6	18.0
5.0	70	54.0	39.2	32.9	20.0

Held with air pressure of 1 MPa.

Dimensions

CSX00-CSX01-CSX02-CSX04

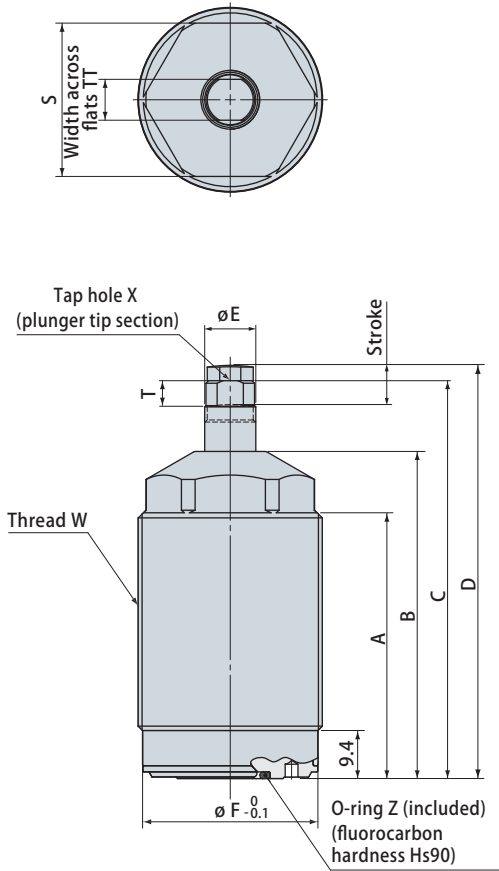

CSX05

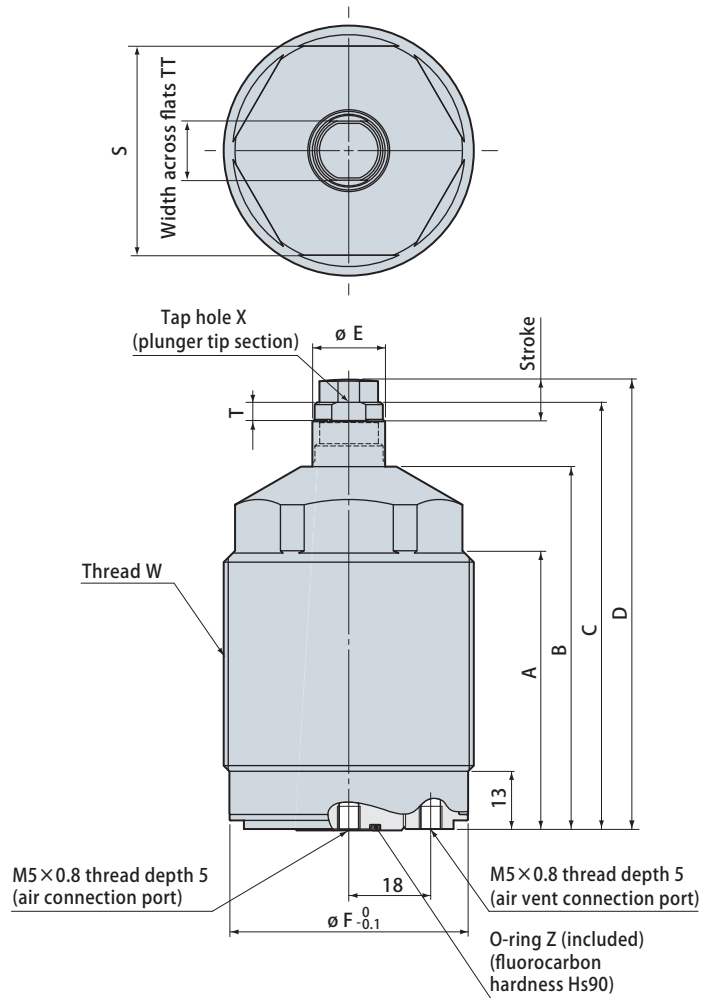

(mm)

Model	CSX00-L <sub>H</sub>	CSX01-L <sub>H</sub>	CSX02-L <sub>H</sub>	CSX04-L <sub>H</sub>	CSX05-L <sub>H</sub>
A	44	51	52	61	61
B	53	60	64	76	80
C	65.5	72.5	78	91	93
D	68.5	75.5	81	95	98
E	10	10	10	12	16
F	24.3	28.3	34.3	43.3	52.5
S (hex width across flats)	22	24	30	36	46
T	5	5	5	6	4
TT	8	8	8	10	13
W	M26×1.5	M30×1.5	M36×1.5	M45×1.5	M55×2
X (nominal size × pitch depth)	M6×1 depth 9	M6×1 depth 9	M6×1 depth 9	M8×1.25 depth 12	M10×1.5 depth 13
Z (O-ring)	AS568-013	AS568-014	AS568-014	AS568-015	AS568-013
Tightening torque (body)	35 ~ 45 N·m	40 ~ 50 N·m	45 ~ 55 N·m	55 ~ 65 N·m	80 ~ 90 N·m
Tightening torque (head cap)	10 N·m	10 N·m	10 N·m	20 N·m	30 N·m

Note 1. Tighten with torque values indicated in the table above when mounting the body.

2. When fixing the hexagon part (S) of body with a vise, etc., make sure the tightening force is 2.5 kN or less.

3. Refer to table above when connecting fitting to CSX05 body.

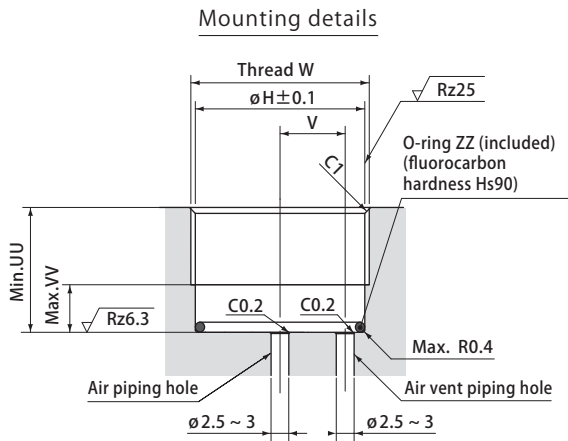

Model	CSX00- $\frac{L}{H}$	CSX01- $\frac{L}{H}$	CSX02- $\frac{L}{H}$	CSX04- $\frac{L}{H}$	CSX05- $\frac{L}{H}$
H	24.5	28.5	34.5	43.5	53
V	9	11	13	15	21
W	M26×1.5	M30×1.5	M36×1.5	M45×1.5	M55×2
UU	20	20	20	20	27
VV	9	9	9	9	12
ZZ (O-ring)	AS568-020	AS568-022	AS568-026	AS568-030	AS568-134

Mounting surface finish must be no rougher than Rz6.3 (ISO4287:1997).

Head cap details

(Hardness: HRC52)

CSX00·CSX01·CSX02·CSX04

CSX05

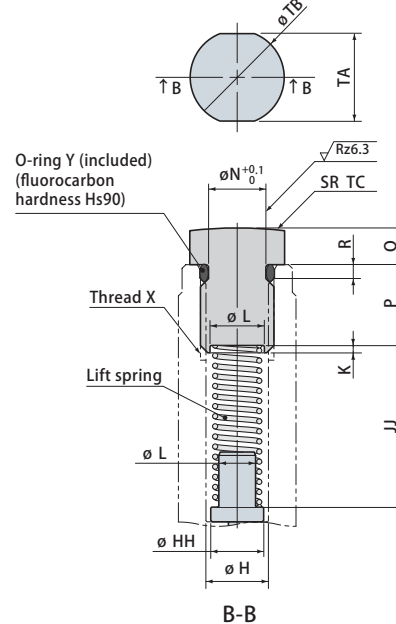
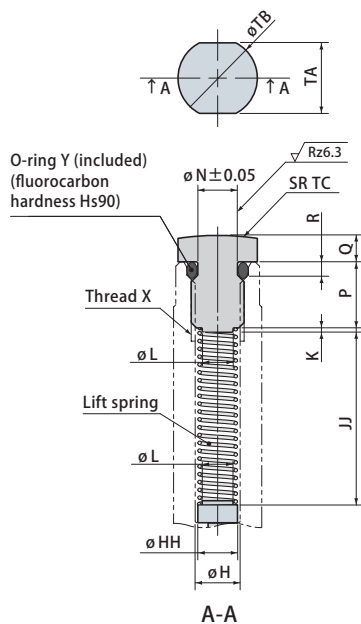

Model	CSX00- $\frac{L}{H}$	CSX01- $\frac{L}{H}$	CSX02- $\frac{L}{H}$	CSX04- $\frac{L}{H}$	CSX05- $\frac{L}{H}$
H	5.1	5.1	5.1	6.8	8.5
HH	4.5	4.5	4.5	5.5	5
JJ	20.5	20.5	20	20.1	22
K	0.5	0.5	0.5	1	1
L	3.5	3.5	3.5	4.3	7.2
N	4.5	4.5	4.5	6	7.8
P	7.5	7.5	7.5	9	11
Q	3	3	3	4	5
R	1.5	1.5	1.5	1.9	2
TA	8	8	8	10	12
TB	9	9	9	11.5	12.9
TC	30	30	30	50	55
Y (O-ring)	S5	S5	S5	S6	S8

Note 1. Always attach head cap (lift spring cannot be retained).

2. For head cap, secure widths across flats of plunger tip section with a spanner, tightening with torque value indicated on page → 307.

3. When fabricating head cap, ensure that O-ring slot, spring spot facing and guide are made by referring to head cap detail diagram. Be sure to always use included O-ring.

4. When fabricating a lift spring, determine dimensions by referring to head cap detail diagram. Furthermore, rustproofing must be implemented (however, there is no guarantee for operation).

5. This diagram indicates a situation where head cap has been fitted into plunger with no pressure applied.

Model designation

CSP ①-C

(Example : CSP02-C)

① Size\*1



<b>CSP</b>	00: For CSS00-CSX00	- C : Piping cap
	Nil: For CSS01-CSX01	
	02: For CSS02-CSX02	
	06: For CSS04-CSX04	

Work support model	CSS00 CSX00	CSS01 CSX01	CSS02 CSX02	CSS04 CSX04	CSS05 CSX05
Piping cap model	CSP00-C	CSP-C	CSP02-C	CSP06-C	(*1)

\*1: Connect CSS05 and CSX05 directly as a connection port is available on body.

(For details about thread size and connecting position, please refer to page → 303 (CSS) and page → 307 (CSX).)

Piping cap

(mm)

Model	CSP00-C	CSP-C	CSP02-C	CSP06-C
C*2	68	75	79	92
D	3	3	3	4
F	32	35	45	54
T	29	32	41	50
W	M26×1.5	M30×1.5	M36×1.5	M45×1.5

\*1: If it is difficult to obtain a BSPP fitting, use of Uni one-touch fitting made by SMC is recommended. (Refer to catalog issued by manufacturer for details.)

\*2: For model CSX, stroke length shall be added on C.

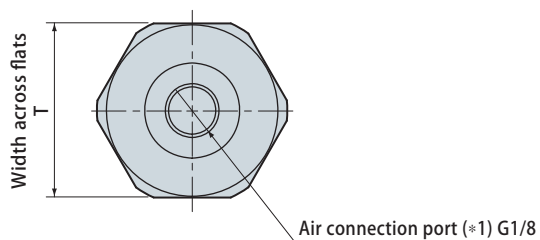
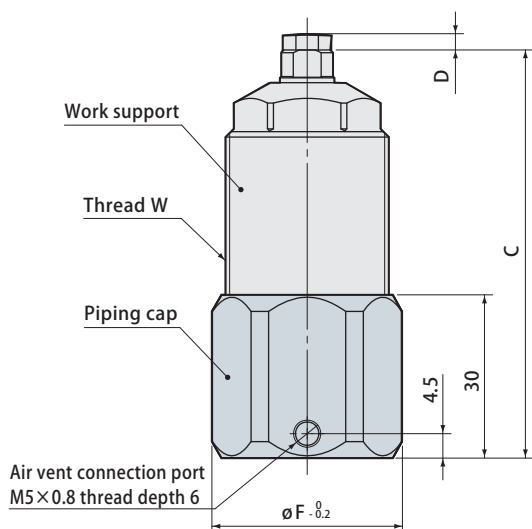

## Flange mounting nut

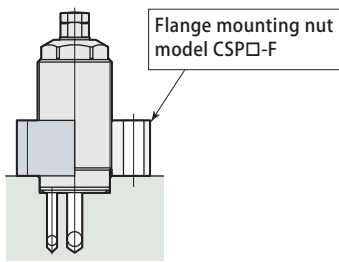

Flange mounting nut (above diagram) is available as option for mounting with screw. Refer to **page** → 141 for details.

## Model designation

CSP ①-F

(Example : CSP045-F)

① Size

CSP

026: For CSS00-CSX00

030: For CSS01-CSX01

036: For CSS02-CSX02

045: For CSS04-CSX04

055: For CSS05-CSX05

- F : Flange mounting nut

## ⚠ Caution in use

1. Set the plunger lifting time to 0.5 seconds or longer by adjusting the speed control.
2. Avoid following usages. These may cause sleeve deformation that could lead to malfunction of plunger or decreased support force.
  - ✗ Applying eccentric load on plunger.
  - ✗ Applying load that exceeds rated support force.
  - ✗ Rotating plunger when locked.
3. Air vent must be opened to atmosphere. Provide the piping if there is a risk of coolant or metal chips intrusion. Allowing intrusion of cutting fluid may cause rusting and other problems.
4. Air (oil free) must be fed through a 5 μm filter that is connected to an air vent connection port for air cleaning (recommended cleaning air pressure: 0.3 to 0.5 MPa). Perform air cleaning only when replacing workpiece. Plunger will rise during air cleaning.

## Air circuit diagram (reference)

