

Work support

model **CSY**

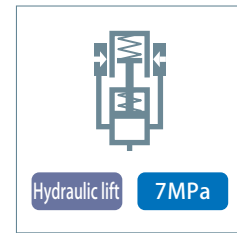

Taper sleeve type work support with improved support force

Large support force

Gripping force between plunger and sleeve is raised and even higher support force is generated.

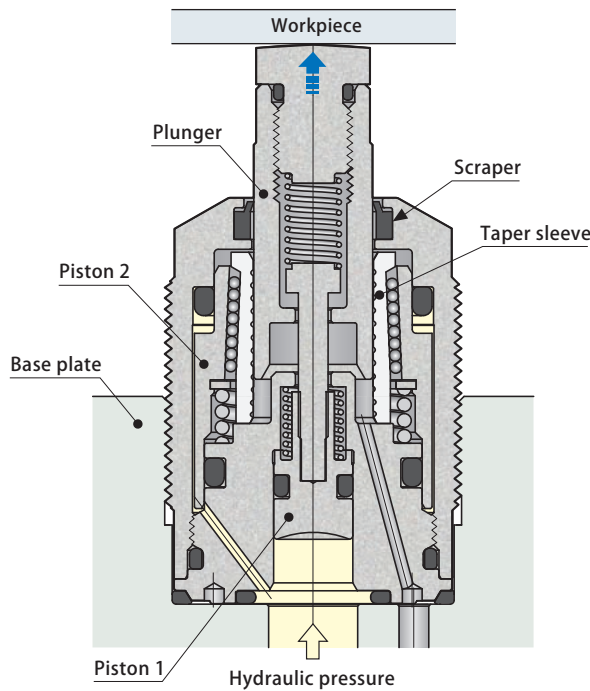
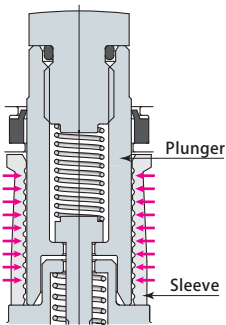

Coolant countermeasure 1

Special low friction type scraper that prevents intrusion by high pressure coolant or metal chips, which comprise the biggest problem with work support, has been adopted to ensure smooth plunger stroke operations. Furthermore, stainless materials are used for principal parts other than body, to improve rustproofing and durability of internal parts.

Patented **Coolant countermeasure 2**

Space between sleeve and plunger can be cleaned by air to prevent intrusion of high pressure coolant or metal chips at the time of workpiece replacement. A dedicated air circuit is required for air cleaning.

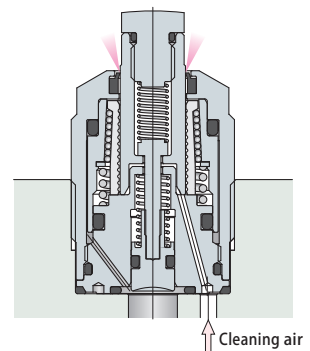

Recommended cleaning air pressure
0.3 ~ 0.5 MPa

Flow control valve Patented

Plunger lifting speed can be controlled by using flow control valve and piping block (option).

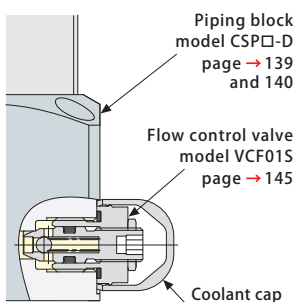

Patent P. **Workpiece contact detection (air sensor)**

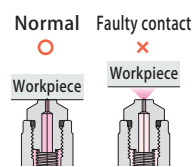

Faulty supported workpiece contact can be detected by using special head cap and air sensor (option).
page → 133

7MPa clamp & work support

Swing clamp

Link clamp

Clamp cylinder

Work support

Option

Specifications

Model		CSY00	CSY03	CSY04	CSY06
Support force (hydraulic pressure 7 MPa) *1 (kN)		3	4	5.5	10
Cylinder capacity (cm ³)		0.6	0.8	1.2	2.0
Lift spring force *2	L : Standard (N)	2 ~ 4	4 ~ 6	5 ~ 8	5 ~ 8
	H : Strong (N)	3 ~ 6	5 ~ 8	6 ~ 11	8 ~ 14
Plunger stroke (mm)		6.5	8	8	10
Max. allowable mass of head cap (kg)		0.05		0.1	
Mass (kg)		0.2	0.3	0.4	0.7

Working pressure range: 2.5 ~ 7 MPa Proof pressure: 10.5 MPa Operating temperature: 0 ~ 70°C

Fluid used: General mineral based hydraulic oil (ISO-VG32 equivalent)

*1 : When work support and clamp are used facing each other, work support and clamp must be selected in such a way that the support force is 1.5 times the applied load (clamping force + machining force).

*2 : Figures are for "upper end ~ lower end" of plunger action.

Fluorocarbon has been adopted for seal sections where cutting fluid is applied, as a measure for the use of chlorine-based cutting fluid (this is not thermal resistant specification).

Model designation

CSY ①-②③ (Example: CSY03-L)

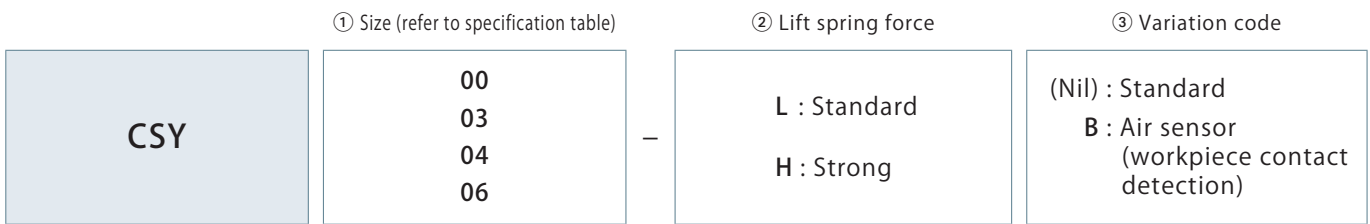

Hydraulic pressure & support force

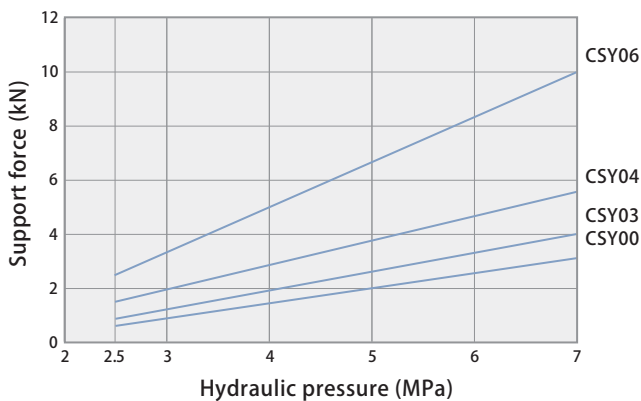

Hydraulic pressure (MPa)	Support force (kN)			
	CSY00	CSY03	CSY04	CSY06
2.5	0.8	1.0	1.4	2.5
3.0	1.0	1.3	1.8	3.3
3.5	1.3	1.7	2.3	4.2
4.0	1.5	2.0	2.8	5.0
4.5	1.8	2.3	3.2	5.8
5.0	2.0	3.7	3.7	6.7
5.5	2.3	3.0	4.1	7.5
6.0	2.5	3.3	4.6	8.3
6.5	2.8	3.7	5.0	9.2
7.0	3.0	4.0	5.5	10.0

Applied load & deformation

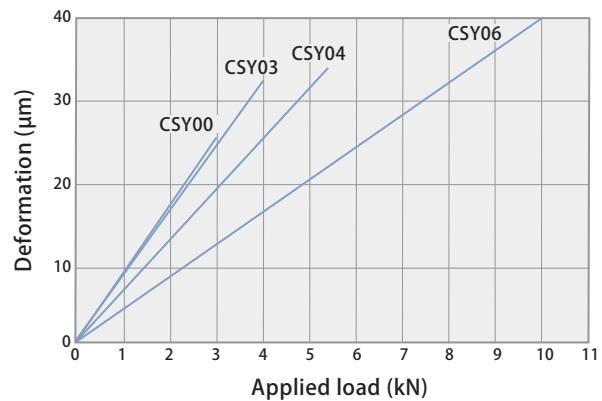

Applied load (kN)	Deformation (µm)			
	CSY00	CSY03	CSY04	CSY06
0	0	0	0	0
1	8	8	6	4
2	17	16	13	8
3	25	24	19	12
4		32	26	16
5			32	20
6				24
7				28
8				32
9				36
10				40

Held with hydraulic pressure of 7 MPa.

Dimension

CSY
00-L
03-H
04-H
06

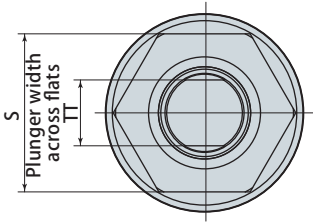

Head cap details

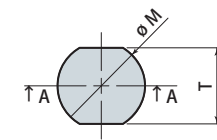

(Hardness: HRc52)

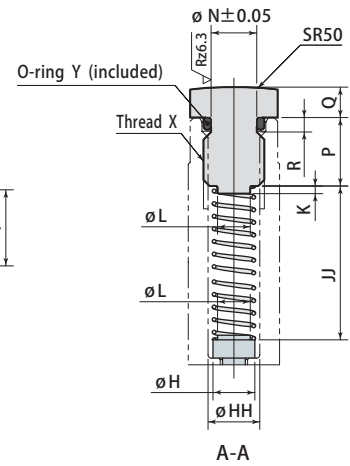

(mm)

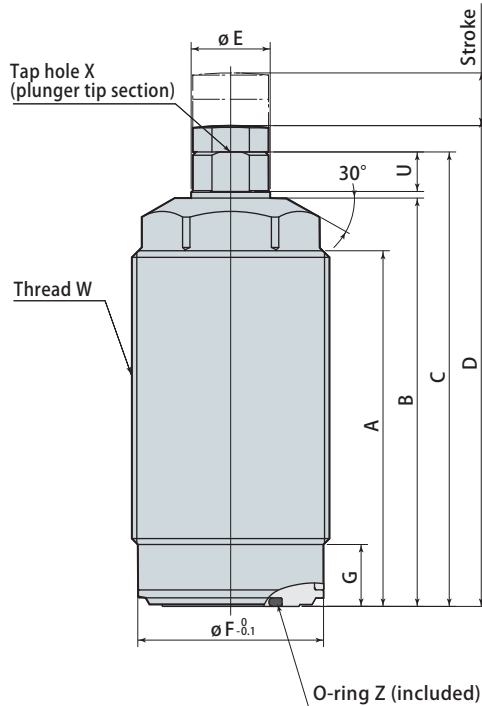

Mounting details

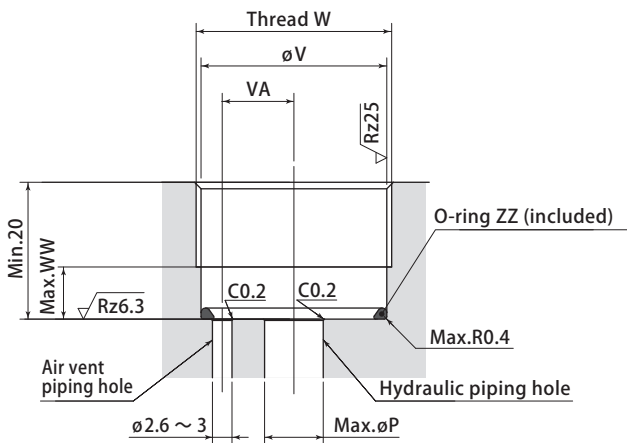

Mounting surface finish must be no rougher than Rz6.3 (ISO 4287:1997).

Model	CSY00-L _H	CSY03-L _H	CSY04-L _H	CSY06-L _H
A	49	54	48	60
B	57	62	58	71
C	63	69	65	78
D	66	73	69	82
E	10	12	15	16
F	24.3	28.2	34.2	43.2
G	8.4	9.4	9.4	9.4
H	4.5	5.5	7.2	7.2
HH	5.1	6.8	8.5	8.5
JJ	20.6	23.2	24.1	32.5
K	1	1	1	1
L	3.5	4.3	5	5
M	9.5	11.5	12.5	12.5
N	4.5	6	7.8	7.8
P	7.5	9	9	9
Q	3	4	4	4
R	1.5	1.9	1.9	1.9
S	22	24	30	36
T	8	10	11	11
TT	8	10	13	13
U	5	6	6	6
V	24.5	28.5	34.5	43.5
VA	9	11	13	16
W (nominal size X pitch)	M26×1.5	M30×1.5	M36×1.5	M45×1.5
WW	8	9	9	9
X (nominal size X pitch depth)	M6×1 depth 9	M8×1.25 depth 12	M10×1.5 depth 11	M10×1.5 depth 11
Y *1	S5	S6	S8	S8
Z *2	AS568-013	AS568-014	AS568-014	AS568-015
ZZ *2	AS568-020	AS568-022	AS568-026	AS568-030
Body tightening torque	35 ~ 45 N·m	40 ~ 50 N·m	45 ~ 55 N·m	55 ~ 65 N·m
Head cap tightening torque	10 N·m	20 N·m	30 N·m	30 N·m

*1 : Material of included O-ring is fluorocarbon (with hardness Hs70).

*2 : Material of included O-ring is fluorocarbon (with hardness Hs90).

Note 1. When fixing the hexagon part of body with a vise, etc., make sure the tightening force is 2.5 kN or less.

2. Always attach head cap (workpiece contact spring cannot be retained). When fabricating head cap, ensure that O-ring slot, spring spot facing and guide are made by referring to head cap details. Be sure to always use O-ring.

3. When fabricating a lift spring, determine dimensions by referring to head cap details. Furthermore, rustproofing must be implemented (however, there is no guarantee for operation).

4. This diagram indicates a situation where head cap has been fitted into plunger with no pressure applied.

Model designation

CSP ①-②

(Example: CSP02-C)

① Size

② Option code

CSP

00 : For CSY00
(Nil): For CSY03
02 : For CSY04
06 : For CSY06

A : Chip cover*
C : Piping cap

*: To be used as a protection cover for hexagonal part of upper part against accumulation of metal chips.

There is no chip cover for CSY00 or CSY04.

Chip cover

00
04-A
06

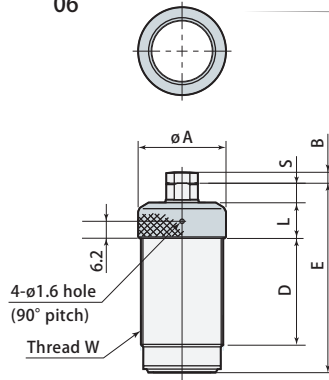

Piping cap

00
04-C
06

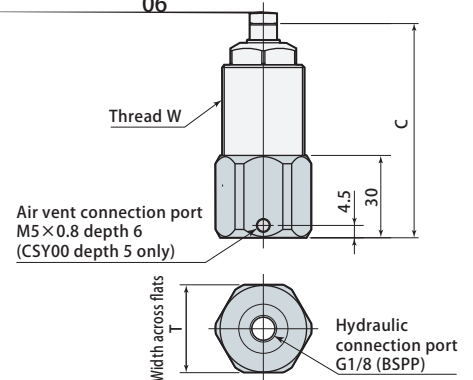

Note: O-ring ZZ is not included.

Model	A	B	C	D	E	L	S	T	W
CSY00	-	3	72	-	63	-	-	29	M26×1.5
CSY03	32	4	78	37.7	69	13	8	32	M30×1.5
CSY04	-	4	74	-	65	-	-	41	M36×1.5
CSY06	47	4	87	42.4	78	16	9.3	50	M45×1.5

Mounting dimensions 1

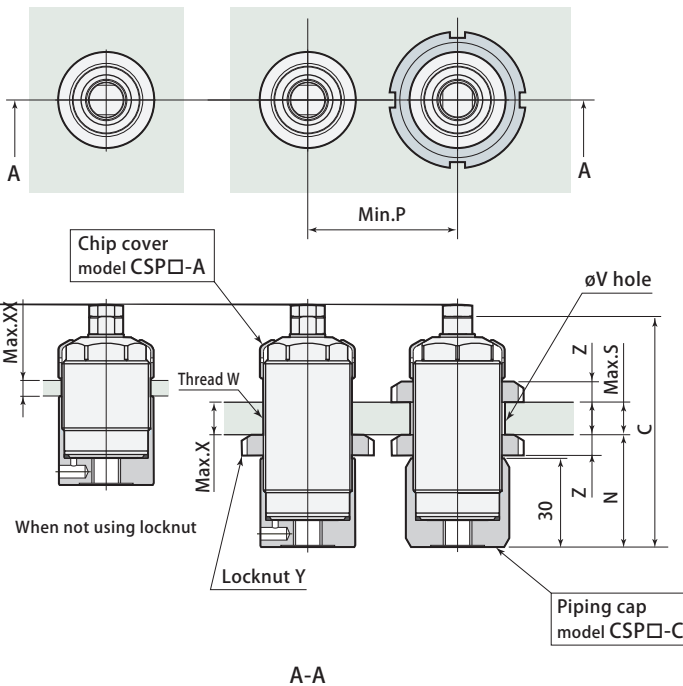

Mounting dimensions 2

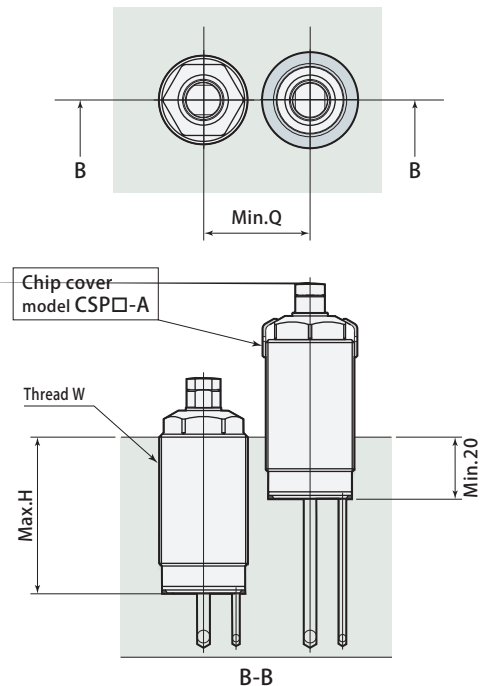

Model	C	H *	N	P	Q	S *	V	W	X *	XX *	Y	Z
CSY00	72	48	-	-	-	-	-	M26×1.5	-	26	-	-
CSY03	78	53	38	46	33	17	30.5	M30×1.5	24	31	AN06	7
CSY04	74	47	-	-	-	-	-	M36×1.5	-	25	-	-
CSY06	87	58	41	86	48	16	45.5	M45×1.5	26	36	AN09	10

*: The dimensions of H, S, X and XX are reduced by 6 mm when chip cover is used.

Air sensor head cap details

00
01
CSY 03-LB
CSN 04-HB
06

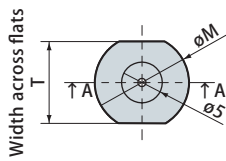

(Hardness: HRC52)

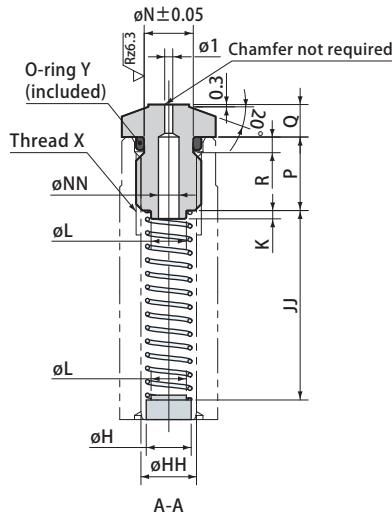

Air catch sensor

For contact detection at the time of work supporting, air sensor type work support and air catch sensor are required.

- For details on air catch sensor, refer to respective catalogs or instruction manuals issued by respective manufacturers before using.

Recommended sensor	SMC ISA2 series CKD GPS2 series
--------------------	------------------------------------

- Connect the supply air for the air catch sensor to the air vent and use dry air that has been passed through a 5 μm filter.
- When performing workpiece contact detection for multiple workpieces (in parallel fittings) using one air sensor, consider detection range of air catch sensor before determining the number of workpiece contacts to be detected.

Workpiece contact force

Workpiece contact force (lift spring force + air pressure lift) is exerted onto workpiece during workpiece setting.

1. Lift spring force varies according to the stroke used. Use following formula to obtain lift spring force:

Lift spring force calculation formula

$$P_s = P_1 - (P_1 - P_2) \times D_2 / D_1$$

Example: model CSN03-LB using stroke of 5 mm:
Lift spring force = $4 - (4 - 2) \times 5 / 8 = 2.75(N)$

2. Workpiece contact force varies according to the air pressure used. Use following formula to obtain workpiece contact force:

Workpiece contact force calculation formula

$$P = P_s + \eta \times P_a$$

Model CSN03-LB using stroke 5 mm and air pressure of 0.05 MPa, Workpiece contact force = $2.75 + 110 \times 0.05 = 8.25(N)$

P1 : Lift spring force at lower end (N)

P2 : Lift spring force at upper end (N)

D1: Full stroke (mm)

D2: Used stroke (mm)

P_s : Lift spring force (N)

η : Push up coefficient
(refer to table at upper left)

P_a : Working air pressure(MPa)

P : Workpiece contact force (N)

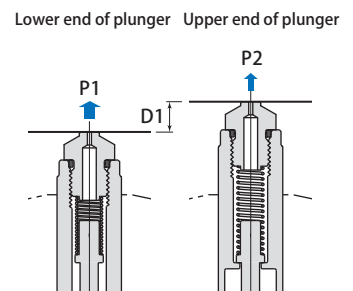

The workpiece contact force varies depending on sliding resistance of scraper. Use calculated figures only as reference. Refer to specification list for details on lift spring force. (CSY page → 126, CSN page → 130)

Model	CSY CSN 00-LB	CSN01-LB	CSY CSN 03-LB	CSY CSN 04-LB	CSY CSN 06-LB
Working air pressure range (MPa)	0.03 ~ 0.1				
Plunger stroke (mm)	6.5	6	8	8	10
Push up coefficient η	80	110	180	180	200

Model	CSY CSN 00-LB	CSN01-LB	CSY CSN 03-LB	CSY CSN 04-LB	CSY CSN 06-LB
H	4.5	5.5		7.2	
HH	5.1	6.8		8.5	
JJ	20.6	11.2	23.2	24.1	32.5
L	3.5	4.3		5	
M	9.5	11.5		12.5	
N	4.5	6		7.8	
NN	2.5	2.5		3.4	
P	7.5	9		9	
Q	3	4		4	
R	1.5	1.9		1.9	
T	8	10		11	
X (nominal size × pitch thread depth)	M6 × 1 depth 9	M8 × 1.25 depth 12		M10 × 1.5 depth 11	
Y	S5	S6		S8	

Note 1. Setting air pressure that exceeds working air pressure range results in leaking of air from scraper and accurate detection will not be possible.

2. If the plunger lowering action slows down due to air pressure, stop air supply during lowering operation.
3. Workpiece contact detection is not possible by simply replacing head cap of standard work support.
4. If cutting fluid enters through head cap tip section hole, then blow air through at all times to prevent cutting fluid from entering.
5. This diagram indicates a situation where head cap has been fitted into plunger with no pressure applied.

1. Set the plunger lifting time to 0.5 seconds or longer by adjusting the flow control valve. Use flow control valve with cracking pressure of 0.05 MPa or less, in order to shorten descending action time of plunger (cracking pressure of optional flow control valve model VCF01S is 0.04 MPa).
2. Avoid following usages. These may cause sleeve deformation that could lead to malfunction of plunger or decreased support force.
 - ✗ Applying eccentric load on plunger.
 - ✗ Applying load that exceeds rated support force.
 - ✗ Rotating plunger when locked.
3. Air vent must be opened to atmosphere. Provide the piping if there is a risk of coolant or metal chips intrusion. Allowing intrusion of cutting fluid may cause rusting and other problems.
4. Air (oil free) must be fed through a 5 μm filter that is connected to an air vent connection port for air cleaning or workpiece contact detection (air sensor). (recommended cleaning air pressure: 0.3 ~ 0.5 MPa.) Perform air cleaning only when replacing workpiece. Plunger will rise during air cleaning.

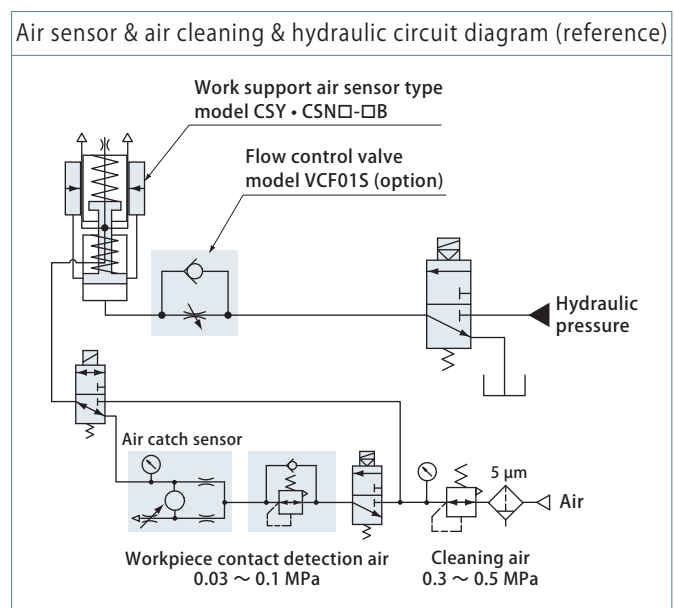
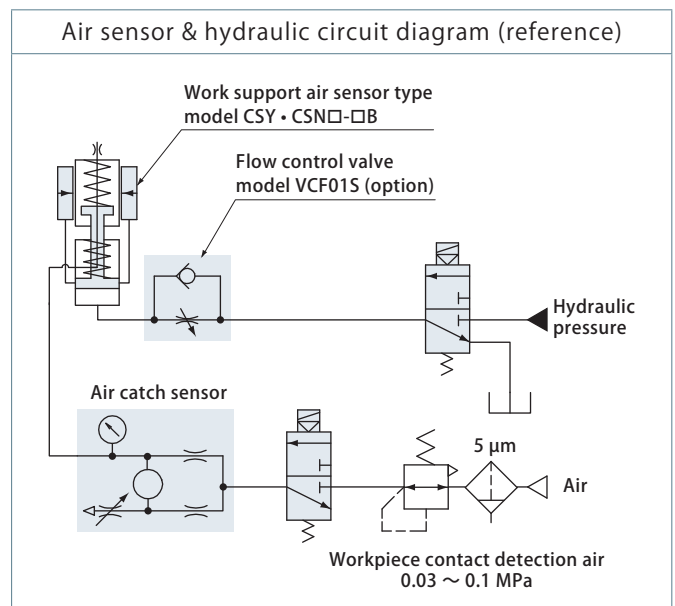
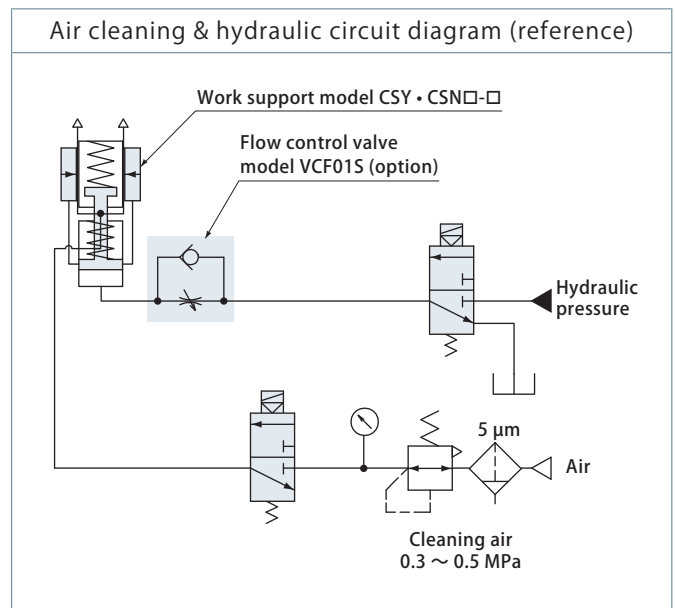

7MPa clamp & work support

Swing clamp

Link clamp

Clamp cylinder

Work support

Option

Mounting of clamp and work support

Use screws with strength class of 12.9 for mounting clamp and work support and be sure to apply specified torque for tightening, by referring to recommended tightening torque of mounting screws indicated below.

Recommended tightening torque of mounting screws (strength class 12.9)

Mounting screws size	Tightening torque
M4 ×0.7	2.8 N·m
M5 ×0.8	7 N·m
M6 ×1	11 N·m
M8 ×1.25	25 N·m
M10×1.5	49 N·m
M12×1.75	60 N·m

Caution in use of equipment

1. Clamp and work supports have been developed for the purpose of clamping workpiece for machine tools. Do not use them for other purposes.
2. Always protect them with a cover to ensure sliding surfaces are not exposed to weld slags when using them as fixture for welding.
3. Clean sliding surfaces and top part of clamp body with air blowing periodically to ensure smooth operations.

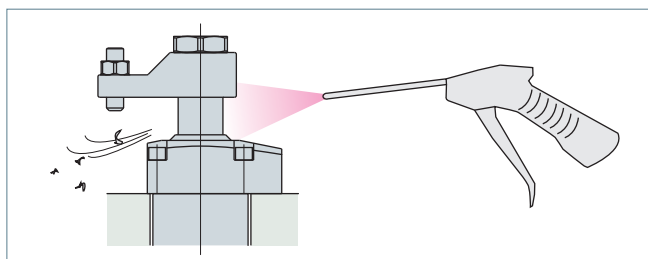

Mounting & dismantling of optional parts

1. When mounting or dismantling a flow control valve or air bleeding valve, be sure to set pressure within hydraulic circuit to 0 MPa before starting.
2. When mounting a flow control valve or air bleeding valve, be sure to tighten it with the specified tightening torque (refer to pages → 145 and 146 for recommended tightening torque).
3. When mounting a coolant cap (resin : POM), firmly press the body of cover. If it is not mounting properly, use a plastic mallet to tap it into place.
4. When dismantling a coolant cap, use a sharp-pointed tool such as a precision screw driver by hooking the notched portion.

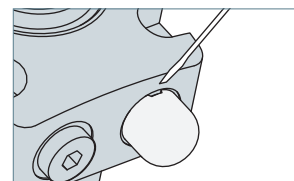

Caution for hydraulic piping

1. Most problems that occur with hydraulic equipment are caused by foreign substances such as metal chips and dust that enter into hydraulic circuits. Refer to "Piping Hydraulic & Pneumatic Equipment-Practical Notes" provided with the product for mounting and hydraulic piping of the product.
2. After performing hydraulic piping, always be sure to bleed out air in the hydraulic circuit. Insufficient bleeding can lead to malfunction.
3. When using multiple clamps, operating speeds and timings vary due to variance in pipe resistance and internal resistance of clamps. Adjust operating speeds and timings using flow control valve.
4. The special scraper has superior scraping capability to remove oil film on the surface of the rod, there are cases where grease and working fluid (oil films) inside the clamp are scraped and expelled to the outside. This may result in accumulation of oil in the external perimeters of piston rod on the upper part of the scraper, but this does not indicate an oil leak.

BSPB port sealing method

1. "Sealing method for flange surfaces" has been adopted as standard means for this product. Use fittings and connectors of bonded seal or elastic body seal. Do not use fittings of "Sealing method for tapered surfaces" (O-ring seal method).
2. Seal tapes and liquid packing are not necessary. Seal fittings with included with packing.
3. When mounting, clean metal chips and dust off surfaces that will come into contact with packing.

Sealing method for flange surfaces

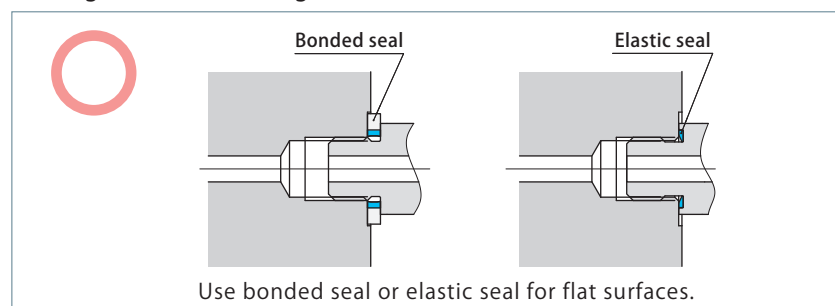

Sealing method for tapered surfaces

