

Swing clamp

model
CTV



ENERPAC-compatible model

High-performance swing clamp featuring high-speed swinging and superior durability

Gothic arch cam groove

Superior durability, high frequency, and high-speed swinging operation is achieved thanks to lowered and controlled seating surface pressure. This is made possible by adopting gothic arch cam grooves that use steel balls with larger surface area.

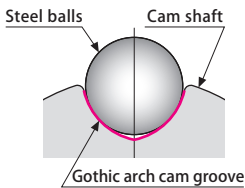

3-point ball support

Smooth, stable and high-speed swinging operation has been achieved by 3-point ball support mechanism.

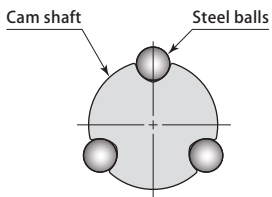

Large diameter cam shaft and wide distance between the cam grooves offers higher rigidity. A overload protection mechanism is not needed due to improvement of durability and impact resistance, providing stable and secure high-speed swing operation.



Cam groove view

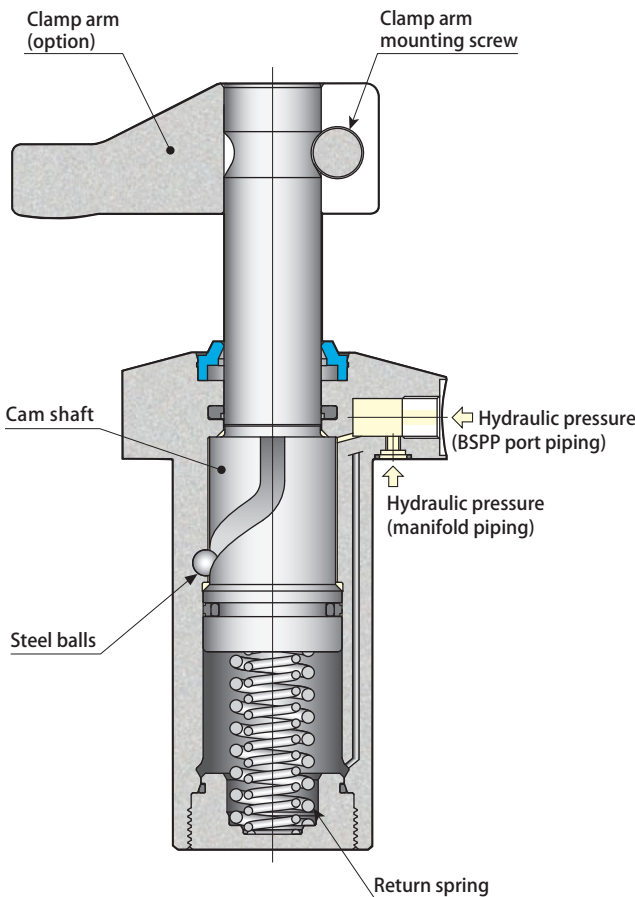

Transverse tightening clamp arm

Transverse tightening type clamp arm featuring easy mounting and angle adjustment.

High pressure coolant & metal chip countermeasure

Special scraper prevents intrusion of high pressure coolant and metal chips into cylinder.

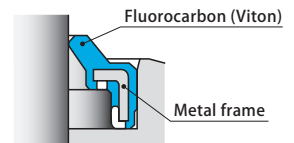

2-way hydraulic piping

BSPP piping connection port and manifold piping connection port are available.

High-speed swing

90° swing 0.3 ~ 0.4 sec.

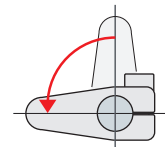

Clamp

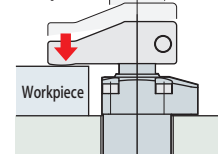

35MPa clamp & work support

Swing clamp

Swing clamp (ROHMHELD-compatible)

Swing clamp (ENERPAC-compatible)

Link clamp

Clamp cylinder

Work support

Option

Model designation

CTV^①^②-^③ (Example : CTV16M-RN45)

	① Size (refer to specification table)	② Mounting and piping types (refer to diagram below)	③ Swing direction, swing angle when clamping (refer to diagram below)
CTV	06	U : Upper flange pages → 379 and 380 B : Lower flange pages → 381 and 382 M : Thread page → 383	L : Counter-clockwise, swing angle 90° (LN30) : Counter-clockwise, swing angle 30° (LN45) : Counter-clockwise, swing angle 45° (LN60) : Counter-clockwise, swing angle 60° R : Clockwise, swing angle 90° (RN30) : Clockwise, swing angle 30° (RN45) : Clockwise, swing angle 45° (RN60) : Clockwise, swing angle 60° (C) : Straight, swing angle 0°
	10		
	16		
	25		

Those in brackets () are made to order.

Mounting and piping types

CTV^①U-^③

CTV^①B-^③

CTV^①M-^③

Upper flange
BSPP port piping

Upper flange
manifold piping

Lower flange
BSPP port piping

Lower flange
manifold piping

Thread
BSPP port piping

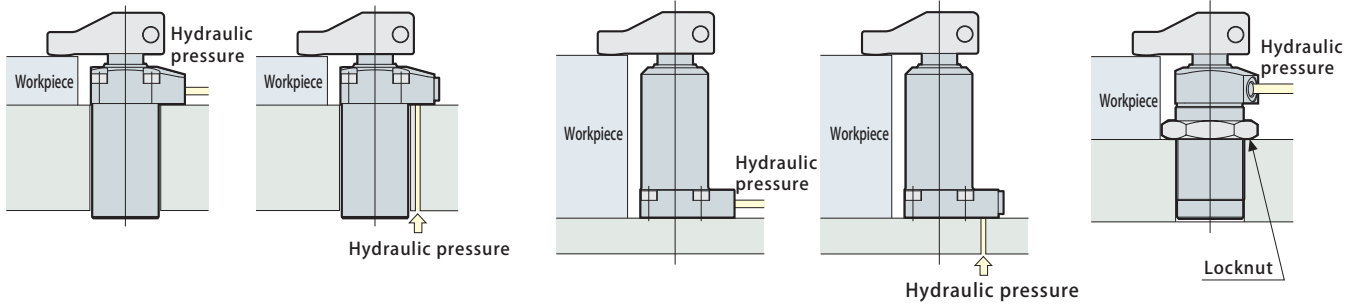

Swing direction (when clamping)

Swing angle

CTV^①^②-L

CTV^①^②-C

CTV^①^②-R

CTV^①^②-LN30
RN30

CTV^①^②-LN45
RN45

Counter-clockwise
Swing angle 90°

Straight
Swing angle 0°

Clockwise
Swing angle 90°

Swing angle 30°

Swing angle 45°

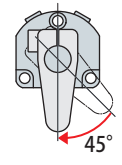
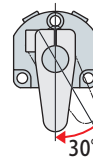
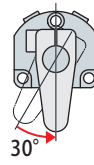
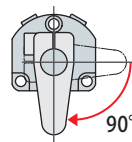
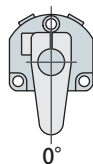
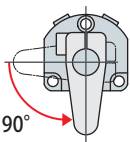

L: Counter-clockwise
R: Clockwise

L: Counter-clockwise
R: Clockwise

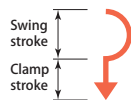
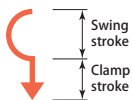

CTV^①^②-LN60
RN60

Swing angle 60°

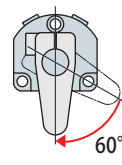
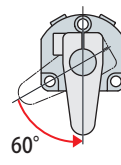

L: Counter-clockwise
R: Clockwise

Refer to pages → 384 to 386 for details.

Specifications

Model		CTV06	CTV10	CTV16	CTV25	
Cylinder force (hydraulic pressure 35 MPa) *1		(kN)	6.0	13.7	18.4	25.1
Clamping force *1 *2	Hydraulic pressure 35 MPa	(kN)	5.2	11.8	15.9	21.8
	Hydraulic pressure 25 MPa	(kN)	3.6	8.3	11.1	15.3
	Hydraulic pressure 15 MPa	(kN)	2.1	4.7	6.4	8.7
Standard clamp arm length (LH)		(mm)	40	50	57	65
Cylinder inner diameter		(mm)	22	32	40	44.5
Rod diameter		(mm)	16	22.4	30	32
Effective area (clamp)		(cm ²)	1.79	4.10	5.50	7.51
Swing angle			90° ± 3°			
Repeated clamp positioning accuracy			± 0.5°			
Full stroke		(mm)	22	28	32	40
Swing stroke (90°)		(mm)	12	15	18	24
Clamp stroke		(mm)	10	13	14	16
Max. swing torque *3		(N·m)	0.35	0.97	1.51	2.10
Max. oil flow rate		(ℓ/min)	0.43	1.23	1.48	2.70
Cylinder capacity		(cm ³)	3.9	11.5	17.6	30.0

Working pressure range: 3.5 ~ 35 MPa Proof pressure: 52.5 MPa Operating temperature: 0 ~ 70°C

Fluid used: General mineral based hydraulic oil (ISO-VG32 equivalent)

*1: This is value for central position of clamp stroke.

*2: Clamping force at time standard clamp arm is mounted (refer to section on W1, W2 series on page → 387).

Clamping force varies depending on clamp arm length. Refer to performance table (page → 378) for details.

*3: This is the limit value for lifting arm at 3.5 MPa when mounted horizontally.

Fluorocarbon has been adopted for seal sections where cutting fluid is applied, as a measure for the use of chlorine-based cutting fluid (this is not thermal resistant specification).

Piping method

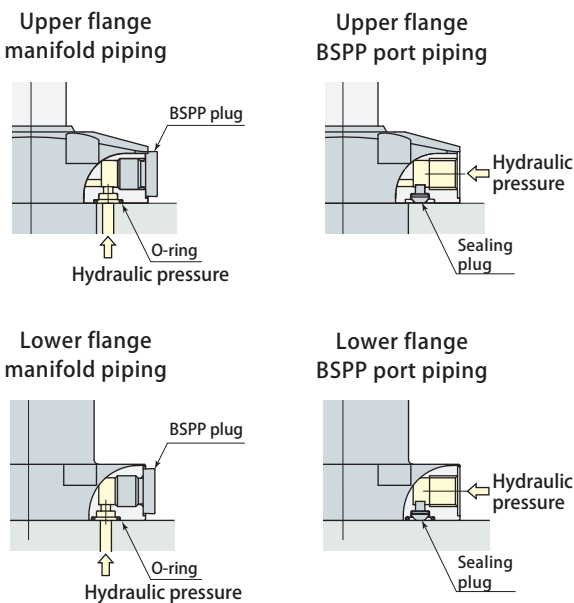

Hydraulic circuit diagram (reference)

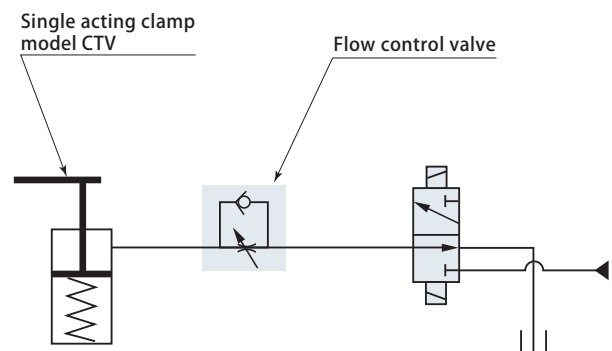

Two piping methods are available for model CTV□U-□ (upper flange) and model CTV□B-□ (lower flange), manifold piping and BSPP port piping.

Remove sealing plug when using manifold piping.

Remove BSPP plug and O-ring when using BSPP port piping.

Use flow control valve for meter-in control.

Flow control valve model VCH can not be mounted.

Performance table

Clamping force varies depending on clamp arm length (LH) and hydraulic pressure. Select an appropriate clamp model based on considerations for clamp arm length, working hydraulic pressure and mounting dimensions.

Note: With swing clamps, force acting on cam mechanism becomes larger as arm becomes longer. Do not use arm lengths that exceed maximum arm length (Max. LH).

How to read performance table (Example 1)

For clamp arm length (LH) of 80 mm and where clamping force of 7.5 kN or more is necessary, the working hydraulic pressure for each model is:

- Not usable with CTV06
- 25 MPa for CTV10
- 20 MPa for CTV16
- 15 MPa for CTV25

How to read performance table (Example 2)

When working hydraulic pressure is 20 MPa with CTV10, clamping force necessary for clamp arm length (LH) is:

- 6.3 kN for LH = 60 mm
- 6.0 kN for LH = 80 mm
- 5.7 kN for LH=100 mm
- Not usable with LH=120 mm

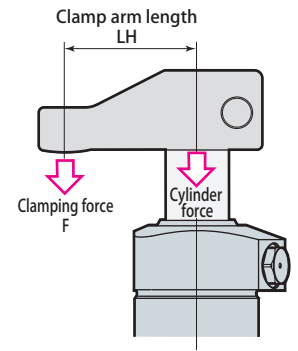

F: Clamping force (kN) P: Working hydraulic pressure (MPa) LH: Clamp arm length (mm)

CTV 06 $F = (P - 1.43) / (5.58 + 0.0224 \times LH)$ indicates nonusable range

Hydraulic pressure (MPa)	Cylinder force (kN)	Clamping force (kN)					Max. arm length Max. LH (mm)
		Clamp arm length LH (mm)					
		40	60	80	100	120	
35	6.0	5.2					44
30	5.1	4.4					54
25	4.2	3.6	3.4				68
20	3.3	2.9	2.7	2.5			93
15	2.4	2.1	2.0	1.8	1.7	1.6	148
10	1.5	1.3	1.2	1.2	1.1	1.0	200
5	0.6	0.6	0.5	0.5	0.5	0.4	↑
3.5	0.4	0.3	0.3	0.3	0.3	0.3	200

CTV 10 $F = (P - 1.65) / (2.46 + 0.00773 \times LH)$ indicates nonusable range

Hydraulic pressure (MPa)	Cylinder force (kN)	Clamping force (kN)					Max. arm length Max. LH (mm)
		Clamp arm length LH (mm)					
		50	60	80	100	120	
35	13.7	11.8					55
30	11.6	10.1	9.8				66
25	9.6	8.3	8.1	7.7			84
20	7.5	6.5	6.3	6.0	5.7		115
15	5.5	4.7	4.6	4.4	4.2	4.0	184
10	3.4	3.0	2.9	2.7	2.6	2.5	240
5	1.4	1.2	1.2	1.1	1.0	1.0	↑
3.5	0.8	0.7	0.6	0.6	0.6	0.6	240

CTV 16 $F = (P - 1.55) / (1.82 + 0.00506 \times LH)$ indicates nonusable range

Hydraulic pressure (MPa)	Cylinder force (kN)	Clamping force (kN)					Max. arm length Max. LH (mm)
		Clamp arm length LH (mm)					
		57	80	100	120	140	
35	18.4	15.9					57
30	15.7	13.5					66
25	12.9	11.1	10.6				83
20	10.2	8.8	8.3	8.0			113
15	7.4	6.4	6.1	5.8	5.6	5.3	175
10	4.7	4.0	3.8	3.7	3.5	3.4	255
5	1.9	1.7	1.6	1.5	1.4	1.4	↑
3.5	1.1	0.9	0.9	0.9	0.8	0.8	255

CTV 25 $F = (P - 1.15) / (1.33 + 0.00310 \times LH)$ indicates nonusable range

Hydraulic pressure (MPa)	Cylinder force (kN)	Clamping force (kN)						Max. arm length Max. LH (mm)
		Clamp arm length LH (mm)						
		65	80	100	120	140	160	
35	25.1	21.8						65
30	21.3	18.5						77
25	17.6	15.3	14.8					97
20	13.8	12.0	11.6	11.2	10.8			131
15	10.0	8.7	8.5	8.2	7.9	7.6	7.3	203
10	6.3	5.5	5.3	5.1	4.9	4.7	4.6	270
5	2.5	2.2	2.1	2.1	2.0	1.9	1.9	↑
3.5	1.4	1.2	1.2	1.1	1.1	1.1	1.0	270

Dimensions

CTV⁰⁶₁₀U-^L/_R/^C

(mm)

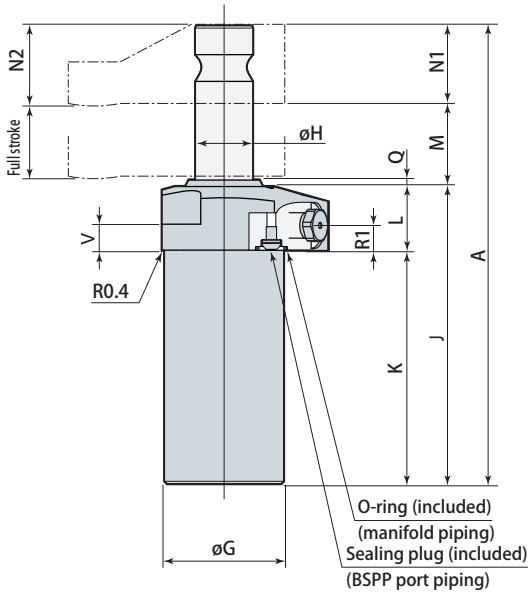
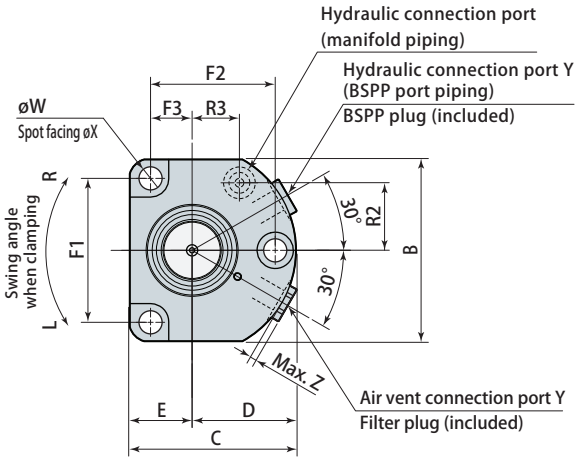

Mounting details

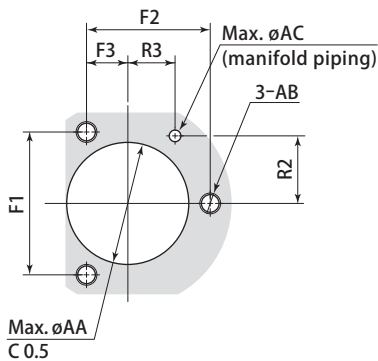

Model	CTV06U- ^L / _R / ^C	CTV10U- ^L / _R / ^C
A	137	176.5
B	56	70
C	50.5	64
D	32.5	40
E	18	24
F1	43.3	55
F2	37.5	47.5
F3	12.5	15.9
G	33 ^{-0.1} / _{-0.2}	46 ^{-0.1} / _{-0.2}
H	16	22.4
J	90.5	114.5
K	66	90
L	24.5	24.5
M	25.5	32
N1	21	30
N2	21.5	31
Q	2	2.5
R1	9.5	9.5
R2	20.5	26
R3	14.3	18.2
V	13	10
W	7	8.9
X	11	14
Y *1	G1/8	G1/8
Z	2.8	2.8
O-ring *2	P9	P9
AA	34	47
AB	M6	M8
AC	7	7
Mass	0.8 kg	1.6 kg

G1/8 (BSPP)

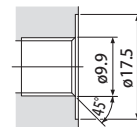

*1: Refer to page → 429 for details on BSPP port piping flareless fitting.
 *2: Material used for O-ring is fluorocarbon (with hardness Hs90).

Note 1. The mounting surface finish must be no rougher than Rz 6.3 (ISO4287:1997) for manifold piping.
 2. Mounting screws are not included.
 3. Air vent must be opened to atmosphere. Provide the piping if there is a risk of coolant or metal chips intrusion.

Dimensions

CTV¹⁶₂₅U-^L_R/^C

(mm)

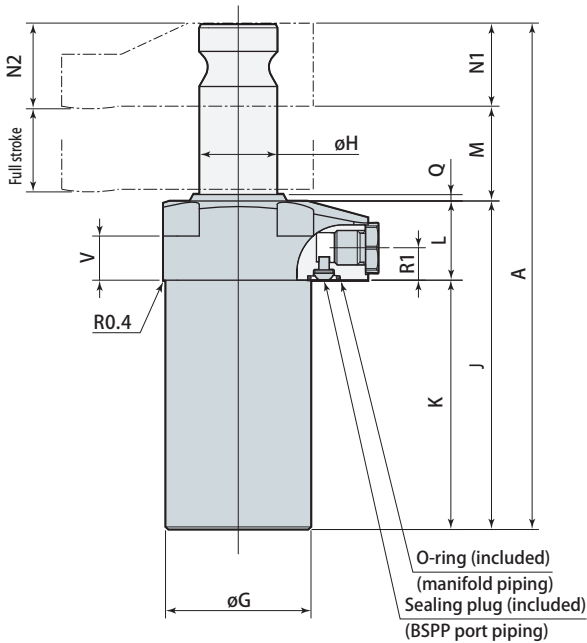
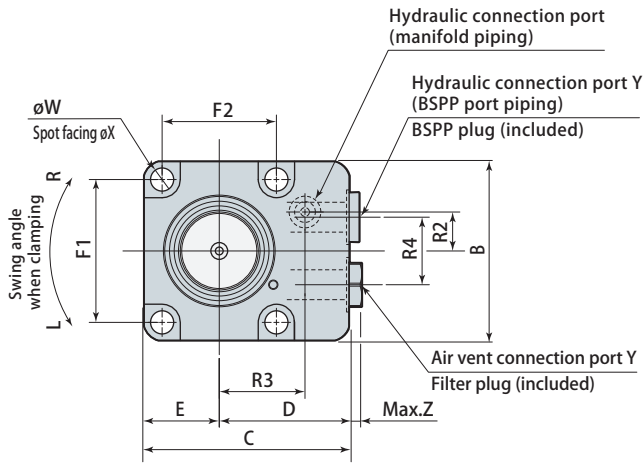

Mounting details

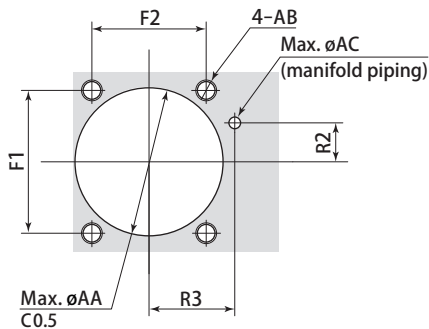

Model	CTV16U- ^L _R / ^C	CTV25U- ^L _R / ^C
A	195	226
B	69	69
C	79	87.5
D	50	53
E	29	34.5
F1	55	55
F2	44	55
G	56 ^{-0.1} _{-0.2}	61.5 ^{-0.1} _{-0.2}
H	30	32
J	126.5	147
K	96	116
L	30.5	31
M	36.5	44
N1	32	35
N2	33	36.5
Q	2.5	2
R1	12.5	12.5
R2	15	15
R3	33	36
R4	26	26
V	17	17
W	8.9	8.9
X	14	14
Y *1	G1/4	G1/4
Z	4.3	4.3
O-ring *2	P9	P9
AA	57	62.5
AB	M8	M8
AC	7	7
Mass	2.6 kg	3.4 kg

G1/4 (BSPP)

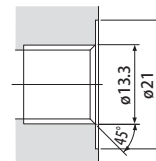

*1: Refer to page → 429 for details on BSPP port piping flareless fitting.
*2: Material used for O-ring is fluorocarbon (with hardness Hs90).

Note 1. The mounting surface finish must be no rougher than Rz 6.3 (ISO4287:1997) for manifold piping.
2. Mounting screws are not included.
3. Air vent must be opened to atmosphere. Provide the piping if there is a risk of coolant or metal chips intrusion.

Dimensions

CTV⁰⁶₁₀B-^L_R^C

(mm)

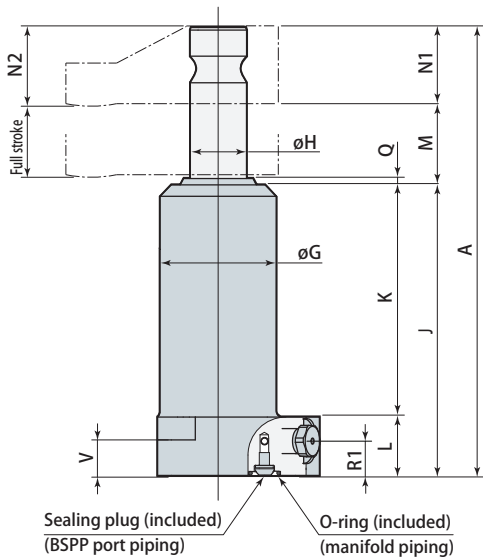
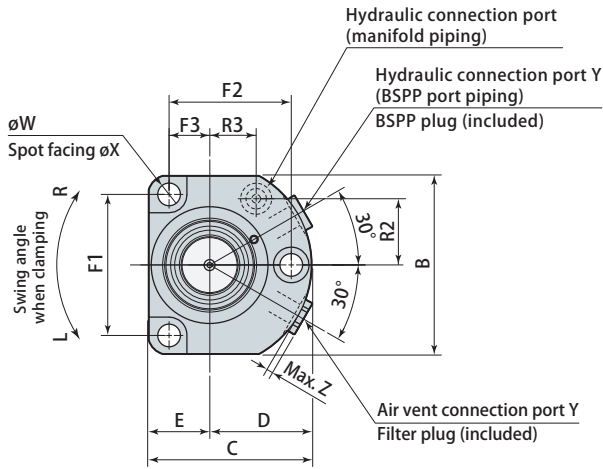

Mounting details

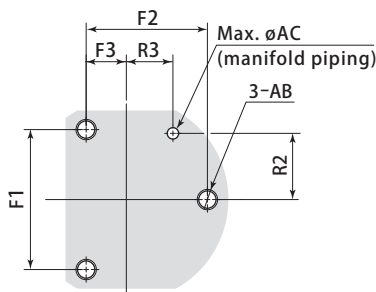

Model	CTV06B- ^L _R ^C	CTV10B- ^L _R ^C
A	137	176.5
B	56	70
C	50.5	64
D	32.5	40
E	18	24
F1	43.3	55
F2	37.5	47.6
F3	12.5	15.9
G	35	46
H	16	22.4
J	90.5	114.5
K	67.5	91.5
L	23	23
M	25.5	32
N1	21	30
N2	21.5	31
Q	2	2.5
R1	13.5	13.5
R2	20.5	26
R3	14.3	18.2
V	16	14
W	7	8.9
X	11	14
Y *1	G1/8	G1/8
Z	2.8	2.8
O-ring *2	P9	P9
AB	M6	M8
AC	7	7
Mass	0.8 kg	1.7 kg

G1/8 (BSPP)

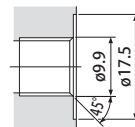

*1: Refer to page → 429 for details on BSPP port piping flareless fitting.
 *2: Material used for O-ring is fluorocarbon (with hardness Hs90).

Note 1. The mounting surface finish must be no rougher than Rz 6.3 (ISO4287:1997) for manifold piping.
 2. Mounting screws are not included.
 3. Air vent must be opened to atmosphere. Provide the piping if there is a risk of coolant or metal chips intrusion.

35MPa clamp & work support

Swing clamp

Swing clamp (ROHMHELD-compatible)

Swing clamp (ENERPAC-compatible)

Link clamp

Clamp cylinder

Work support

Option

Dimensions

CTV¹⁶₂₅B-^L_R-^L_C

(mm)

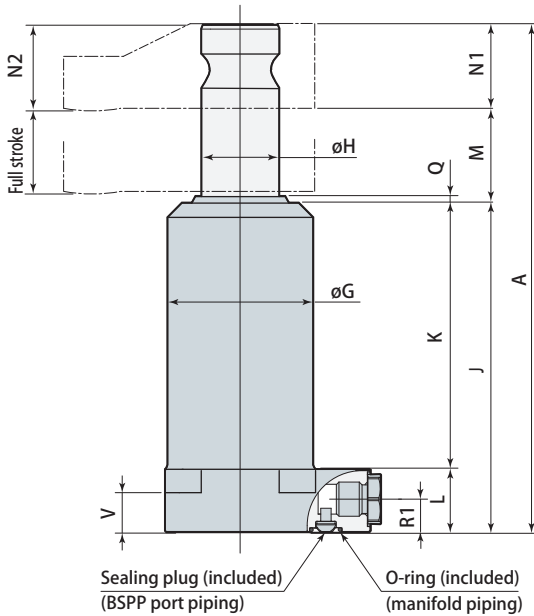
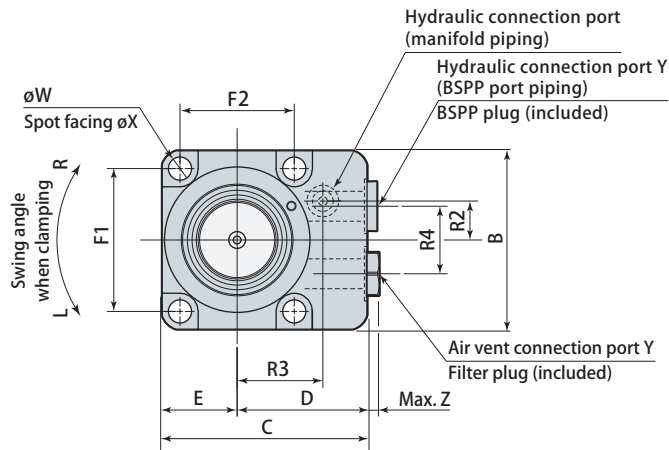

Mounting details

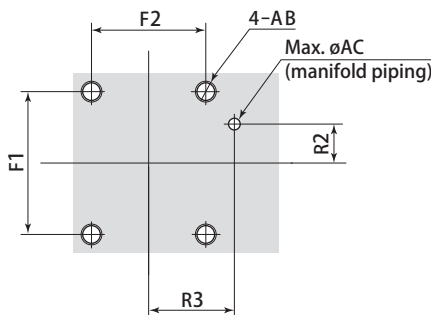

Model	CTV16B- ^L _R - ^L _C	CTV25B- ^L _R - ^L _C
A	195	226
B	69	69
C	79	87.5
D	50	53
E	29	34.5
F1	55	55
F2	44	55
G	56	61.5
H	30	32
J	126.5	147
K	102.5	123
L	24	24
M	36.5	44
N1	32	35
N2	33	36.5
Q	2.5	2
R1	12.5	12.5
R2	15	15
R3	33	36
R4	26	26
V	15	15
W	8.9	8.9
X	14	14
Y *1	G1/4	G1/4
Z	4.3	4.3
O-ring *2	P9	P9
AB	M8	M8
AC	7	7
Mass	2.7 kg	3.5 kg

G1/4 (BSPP)

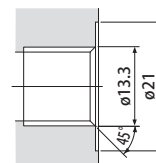

*1: Refer to page → 429 for details on BSPP port piping flareless fitting.
 *2: Material used for O-ring is fluorocarbon (with hardness Hs90).

Note 1. The mounting surface finish must be no rougher than Rz 6.3 (ISO4287:1997) for manifold piping.
 2. Mounting screws are not included.
 3. Air vent must be opened to atmosphere. Provide the piping if there is a risk of coolant or metal chips intrusion.

Dimensions

CTV ⁰⁶₁₀¹⁶₂₅ M-^L_R-^C

(mm)

Model	CTV06M- ^L _R - ^C	CTV10M- ^L _R - ^C	CTV16M- ^L _R - ^C	CTV25M- ^L _R - ^C
A	137	176.5	195	226
B	36	48	57	63.5
C	47	56	69	74
D	29	32	40	42
E	18	24	29	32
G	M35×1.5	M48×1.5	M58×1.5	M65×1.5
H	16	22.4	30	32
J	90.5	114.5	126.5	147
K	66	90	97	117
L	24.5	24.5	29.5	30
M	25.5	32	36.5	44
N1	21	30	32	35
N2	21.5	31	33	36.5
Q	2	2.5	2.5	2
R1	9.5	9.5	11.5	11.5
S	11	14	15	15
Y *1	G1/8	G1/8	G1/4	G1/4
Z	2.5	2.5	3.5	3.5
Mass	0.7 kg	1.5 kg	2.4 kg	3.2 kg

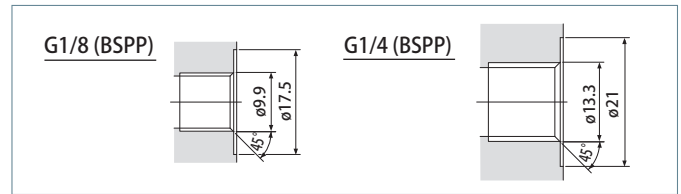
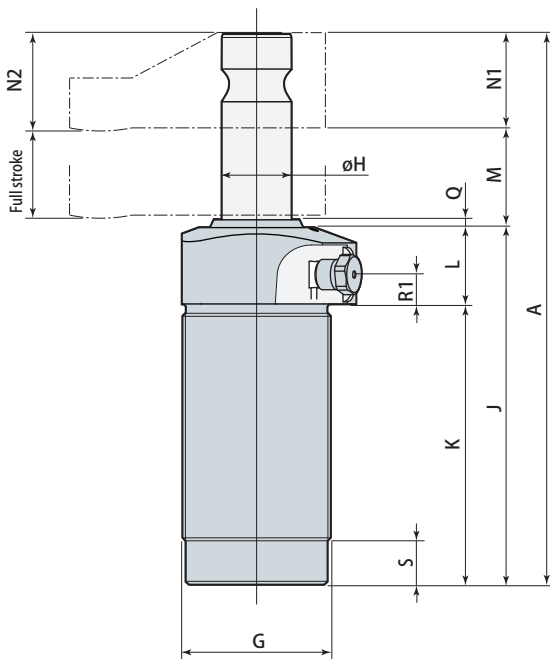
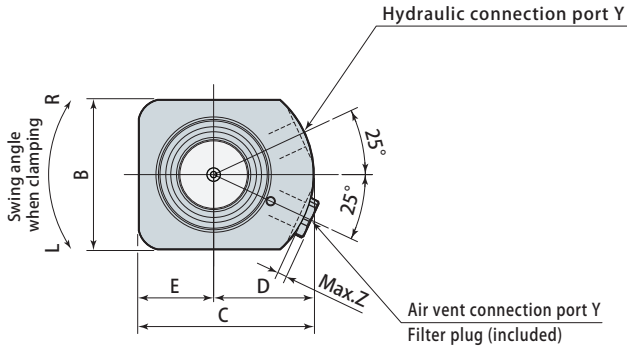

*1: Refer to page → 429 for details on BSPP port piping flareless fitting.
 Note 1. Locknuts are not included.
 2. Air vent must be opened to atmosphere. Provide the piping if there is a risk of coolant or metal chips intrusion.

Locknut (Option)

CTH ⁰⁶₁₀¹⁶₂₅ -VM

(mm)

Locknut models	CTH06-VM	CTH10-VM	CTH16-VM	CTH25-VM
A	M35×1.5	M48×1.5	M58×1.5	M65×1.5
B	8	10	11	12
C	44	56	73	79
D	52	65	80	85
S	5	6	7	7
T	2	2.5	3	3
Clamp models	CTV06M	CTV10M	CTV16M	CTV25M

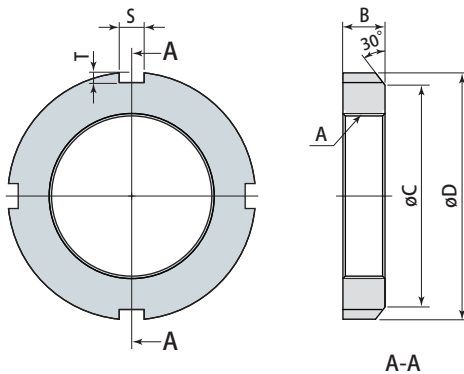

35MPa clamp & work support

Swing clamp

Swing clamp (ROEMHELD-compatible)

Swing clamp (ENERPAC-compatible)

Link clamp

Clamp cylinder

Work support

Option

Dimensions

CTV⁰⁶₁₀U-L^{N30}_R^{N45}^{N60}

CTV¹⁶₂₅U-L^{N30}_R^{N45}^{N60}

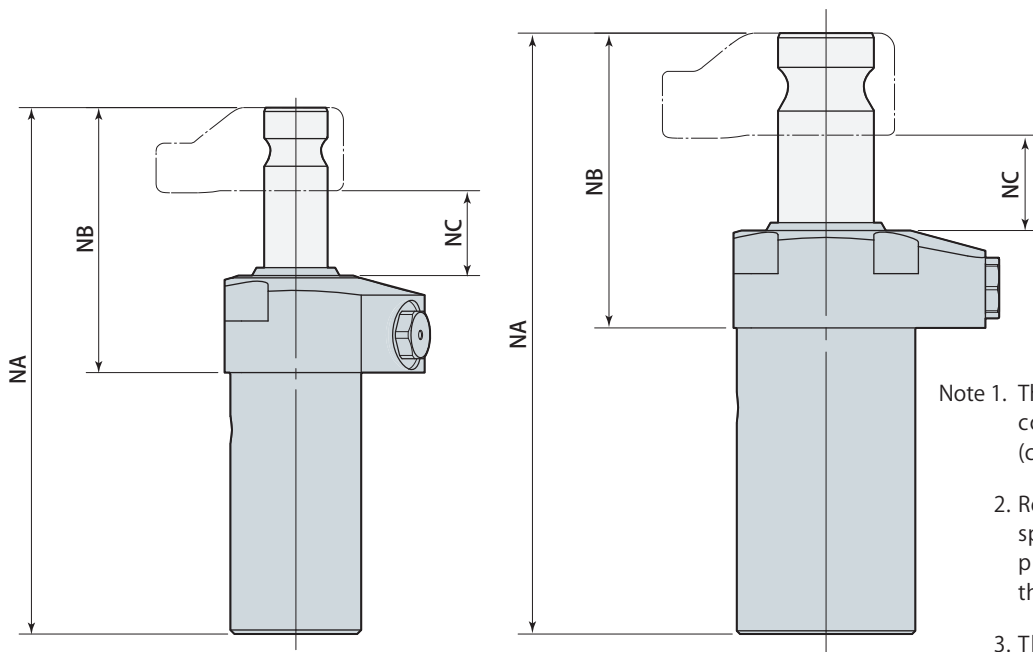
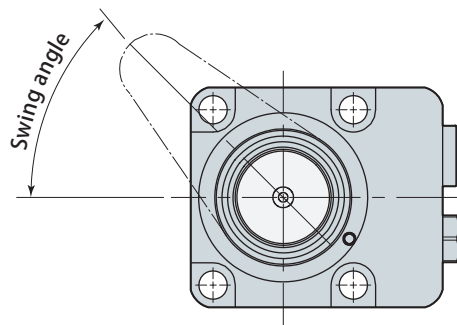
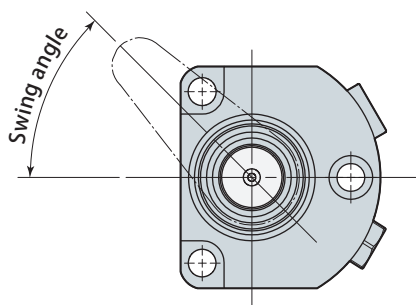

Note 1. This diagram indicates unclamped condition of swing direction L (counter-clockwise).

2. Refer to pages → 379 and 380 for specifications and dimensions of products that are not listed on this page.

3. This product is made to order.

Model	CTV06U-L ^{N30} _R ^{N45} ^{N60}			CTV10U-L ^{N30} _R ^{N45} ^{N60}			CTV16U-L ^{N30} _R ^{N45} ^{N60}			CTV25U-L ^{N30} _R ^{N45} ^{N60}		
	30° ± 5°	45° ± 5°	60° ± 5°	30° ± 5°	45° ± 5°	60° ± 5°	30° ± 5°	45° ± 5°	60° ± 5°	30° ± 5°	45° ± 5°	60° ± 5°
Swing angle												
Full stroke (mm)	16.5	17.9	19.3	20.7	22.5	24.3	23.3	25.5	27.6	28.0	31.0	34.0
Swing stroke (mm)	6.5	7.9	9.3	7.7	9.5	11.3	9.3	11.5	13.6	12.0	15.0	18.0
Clamp stroke (mm)	10			13			14			16		
Cylinder capacity (cm ³)	3.0	3.2	3.5	8.5	9.2	10.0	12.8	14.0	15.2	21.0	23.3	25.5
NA	131.5	132.9	134.3	169.2	171.0	172.8	186.3	188.5	190.6	214.0	217.0	220.0
NB	65.5	66.9	68.3	79.2	81.0	82.8	90.3	92.5	94.6	98.0	101.0	104.0
NC	20.0	21.4	22.8	24.7	26.5	28.3	27.8	30.0	32.1	32.0	35.0	38.0

Dimensions

CTV⁰⁶₁₀B-L^{N30}_R^{N45}_{N60}

CTV¹⁶₂₅B-L^{N30}_R^{N45}_{N60}

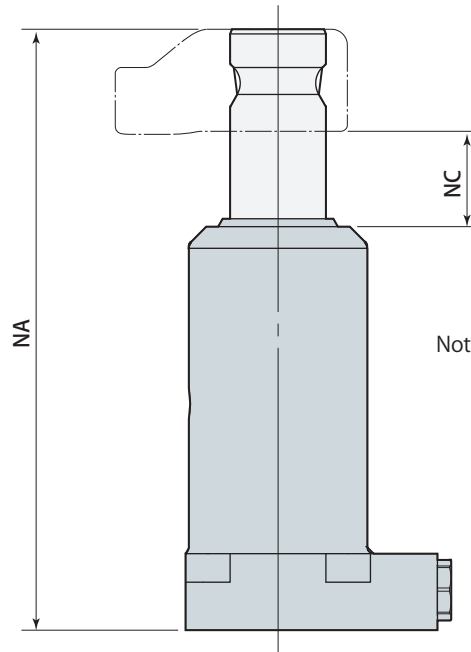
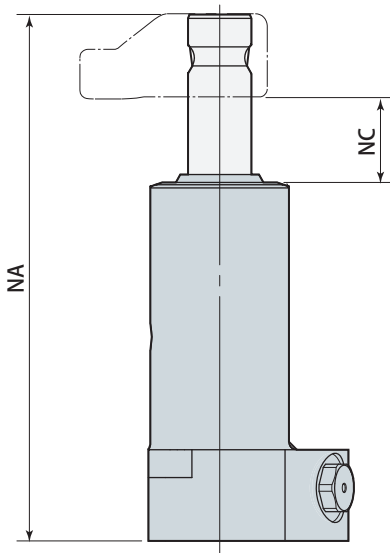
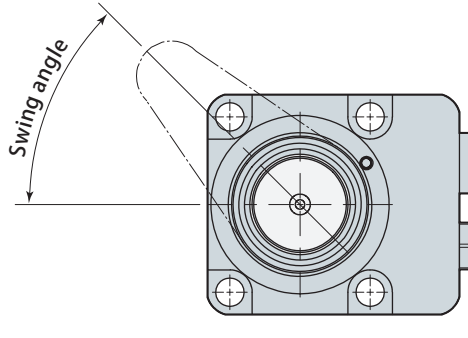
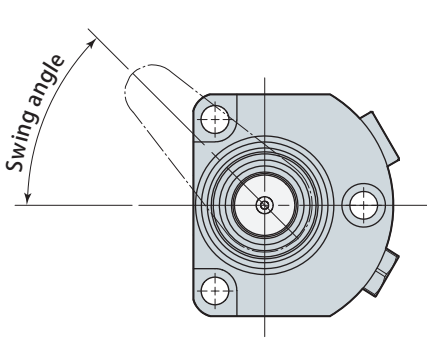

Note 1. This diagram indicates unclamped condition of swing direction L (counter-clockwise).

2. Refer to pages → 381 and 382 for specifications and dimensions of products that are not listed on this page.

3. This product is made to order.

(mm)

Model	CTV06B-L ^{N30} _R ^{N45} _{N60}			CTV10B-L ^{N30} _R ^{N45} _{N60}			CTV16B-L ^{N30} _R ^{N45} _{N60}			CTV25B-L ^{N30} _R ^{N45} _{N60}		
	30° ± 5°	45° ± 5°	60° ± 5°	30° ± 5°	45° ± 5°	60° ± 5°	30° ± 5°	45° ± 5°	60° ± 5°	30° ± 5°	45° ± 5°	60° ± 5°
Swing angle	30° ± 5°	45° ± 5°	60° ± 5°	30° ± 5°	45° ± 5°	60° ± 5°	30° ± 5°	45° ± 5°	60° ± 5°	30° ± 5°	45° ± 5°	60° ± 5°
Full stroke (mm)	16.5	17.9	19.3	20.7	22.5	24.3	23.3	25.5	27.6	28.0	31.0	34.0
Swing stroke (mm)	6.5	7.9	9.3	7.7	9.5	11.3	9.3	11.5	13.6	12.0	15.0	18.0
Clamp stroke (mm)	10			13			14			16		
Cylinder capacity (cm ³)	3.0	3.2	3.5	8.5	9.2	10.0	12.8	14.0	15.2	21.0	23.3	25.5
NA	131.5	132.9	134.3	169.2	171.0	172.8	186.3	188.5	190.6	214.0	217.0	220.0
NC	20.0	21.4	22.8	24.7	26.5	28.3	27.8	30.0	32.1	32.0	35.0	38.0

35MPa clamp & work support

Swing clamp

Swing clamp (ROHMHELD-compatible)

Swing clamp (ENERPAC-compatible)

Link clamp

Clamp cylinder

Work support

Option

Dimensions

CTV⁰⁶₁₀¹⁶₂₅M-L^{N30}_R^{N45}_{N60}

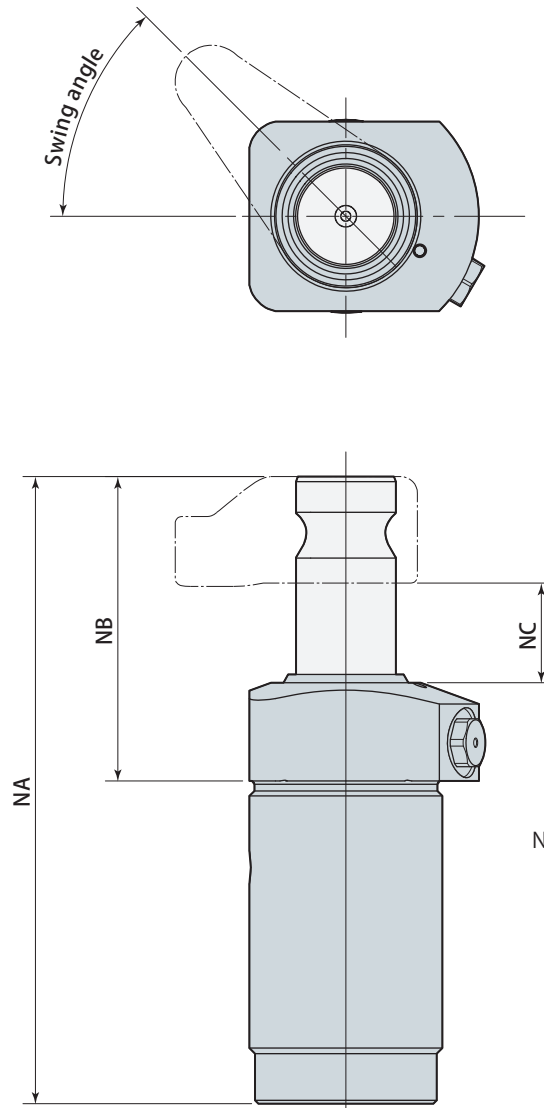

- Note 1. This diagram indicates unclamped condition of swing direction L (counter-clockwise).
2. Refer to page → 383 for specifications and dimensions of products that are not listed on this page.
3. This product is made to order.

Model	CTV06M-L ^{N30} _R ^{N45} _{N60}			CTV10M-L ^{N30} _R ^{N45} _{N60}			CTV16M-L ^{N30} _R ^{N45} _{N60}			CTV25M-L ^{N30} _R ^{N45} _{N60}		
	30° ± 5°	45° ± 5°	60° ± 5°	30° ± 5°	45° ± 5°	60° ± 5°	30° ± 5°	45° ± 5°	60° ± 5°	30° ± 5°	45° ± 5°	60° ± 5°
Swing angle												
Full stroke (mm)	16.5	17.9	19.3	20.7	22.5	24.3	23.3	25.5	27.6	28.0	31.0	34.0
Swing stroke (mm)	6.5	7.9	9.3	7.7	9.5	11.3	9.3	11.5	13.6	12.0	15.0	18.0
Clamp stroke (mm)	10			13			14			16		
Cylinder capacity (cm ³)	3.0	3.2	3.5	8.5	9.2	10.0	12.8	14.0	15.2	21.0	23.3	25.5
NA	131.5	132.9	134.3	169.2	171.0	172.8	186.3	188.5	190.6	214.0	217.0	220.0
NB	65.5	66.9	68.3	79.2	81.0	82.8	90.3	92.5	94.6	98.0	101.0	104.0
NC	20.0	21.4	22.8	24.7	26.5	28.3	27.8	30.0	32.1	32.0	35.0	38.0

W1 Clamp arm

W2 Clamp arm

06
CTH₁₀¹⁶-W1
25

06
CTH₁₀¹⁶-W2
25

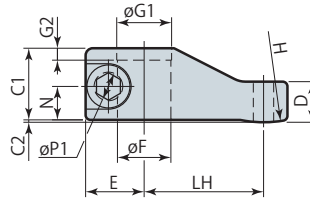
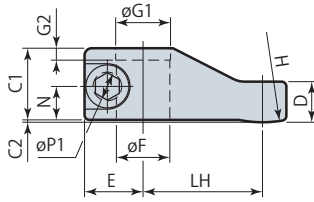
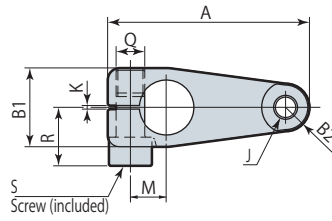
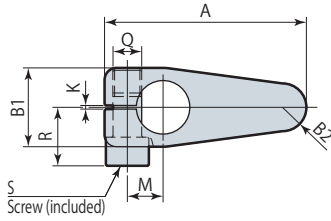

Material: SCM440 (Refining HB285~344)

(mm)

Clamp arm models	CTH06-W1 W2	CTH10-W1 W2	CTH16-W1 W2	CTH25-W1 W2
A	64.5	84.5	98	113
B1	24	33	43	49
B2	7	10	11	15
C1	21	30	32	35
C2	0.5	1	1	1.5
D	12.5	17	21	21.5
E	17.5	24.5	30	33
F	16 ^{+0.003 -0.015}	22.4 ^{+0.004 -0.017}	30 ^{+0.004 -0.017}	32 ^{+0.005 -0.020}
G1	—	23	—	33
G2	—	5	—	6
H	50	50	60	75
J	M8×1.25	M10×1.5	M10×1.5	M12×1.75
K	2	2	2	2
LH	40	50	57	65
M	10.5±0.1	15±0.1	19±0.1	20.5±0.1
N	10	14	15	16
P1	8 ^{+0.015 0}	12 ^{+0.018 0}	14 ^{+0.018 0}	16 ^{+0.018 0}
Q	M8×1.0	M12×1.5	M14×1.5	M16×1.5
R	16.5	24.5	29.5	34.5
S (screw)	CTH06-VB	CTH10-VB	CTH16-VB	CTH25-VB
Mass	0.13 kg	0.33 kg	0.52 kg	0.78 kg
Clamp models	CTW06 CTV06	CTW10 CTV10	CTW16 CTV16	CTW25 CTV25

WL Clamp arm

06
CTH₁₀¹⁶-WL
25

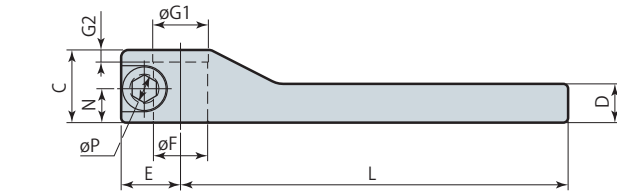
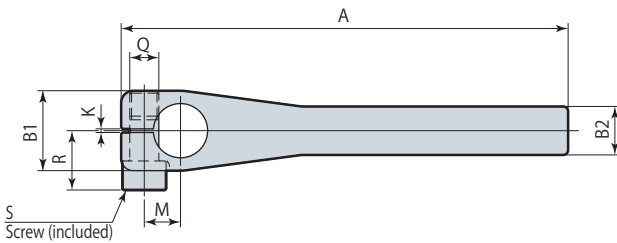

Material: SCM440 (Refining HB285~344)

(mm)

Clamp arm models	CTH06-WL	CTH10-WL	CTH16-WL	CTH25-WL
A	152.5	184.5	200	213
B1	24	33	43	49
B2	14	20	22	30
C	21	30	32	35
D	12	16	20	20
E	17.5	24.5	30	33
F	16 ^{+0.003 -0.015}	22.4 ^{+0.004 -0.017}	30 ^{+0.004 -0.017}	32 ^{+0.005 -0.020}
G1	—	23	—	33
G2	—	5	—	6
K	2	2	2	2
L	135	160	170	180
M	10.5±0.1	15±0.1	19±0.1	20.5±0.1
N	10	14	15	16
P	8 ^{+0.015 0}	12 ^{+0.018 0}	14 ^{+0.018 0}	16 ^{+0.018 0}
Q	M8×1.0	M12×1.5	M14×1.5	M16×1.5
R	16.5	24.5	29.5	34.5
S (screw)	CTH06-VB	CTH10-VB	CTH16-VB	CTH25-VB
Mass	0.24 kg	0.58 kg	0.87 kg	1.25 kg
Clamp models	CTW06 CTV06	CTW10 CTV10	CTW16 CTV16	CTW25 CTV25

Screw

06
CTH₁₀¹⁶-VB
25

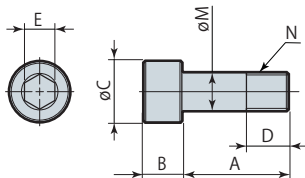

(mm)

Screw models	CTH06-VB	CTH10-VB	CTH16-VB	CTH25-VB
A	20	28	35	41
B	8	12	14	16
C	13	18	21	24
D	9	11	13	15
E	6	10	12	14
M	8 ^{-0.01 -0.05}	12 ^{-0.01 -0.05}	14 ^{-0.01 -0.05}	16 ^{-0.01 -0.05}
N	M8×1.0	M12×1.5	M14×1.5	M16×1.5
Clamp models	CTW06 CTV06	CTW10 CTV10	CTW16 CTV16	CTW25 CTV25

35MPa clamp & work support

Swing clamp

Swing clamp
(ROEMHELD-compatible)

Swing clamp
(ENERPAC-compatible)

Link clamp

Clamp cylinder

Work support

Option

When fabricating clamp arm, refer to diagram shown below for shape and dimensions of mounting portion.

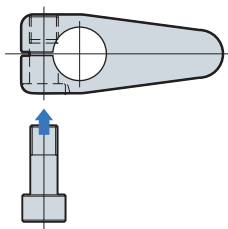
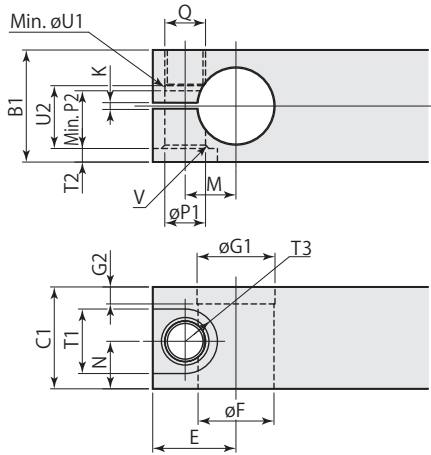

Note 1. Install mounting screws for arm from direction shown in left diagram viewed from top. Installation from the opposite direction can cause loosened screws and resultant broken rod.

(mm)

Clamp models	CTW06 CTV06	CTW10 CTV10	CTW16 CTV16	CTW25 CTV25
B1	24	33	43	49
C1	21	30	32	35
E	17.5	24.5	30	33
F	16 ^{+0.003} _{-0.015}	22.4 ^{+0.004} _{-0.017}	30 ^{+0.004} _{-0.017}	32 ^{+0.005} _{-0.020}
G1	—	23	—	33
G2	—	5	—	6
K	2	2	2	2
M	10.5±0.1	15±0.1	19±0.1	20.5±0.1
N	10	14	15	16
P1	8 ^{+0.015} ₀	12 ^{+0.018} ₀	14 ^{+0.018} ₀	16 ^{+0.018} ₀
P2	11	17	22	26
Q	M8×1.0	M12×1.5	M14×1.5	M16×1.5
T1	14	19	22	25
T2	3.5	4	6	6
T3	7	9.5	11	12.5
U1	7.9	11.9	13.9	15.9
U2	12.5	18.5	23.5	27.5
V	C1	C1	C1.5	C1.5

Caution in use

Mounting & dismounting of clamp arm

Cam mechanism may be damaged if excessive torque is applied to piston rod, since swing clamp structure is intended for swinging clamp arm using cam mechanism with lead grooves.

Loosen screw (CTH □ -VB) before mounting or dismounting clamp arm, or adjusting position of clamp arm, to prevent excessive rotating torque from being applied on piston rod.

Refer to table below for screw tightening torque.

Clamp models	Thread size	Tightening torque
CTW06 / CTV06	M 8	30 N•m
CTW10 / CTV10	M12	100 N•m
CTW16 / CTV16	M14	150 N•m
CTW25 / CTV25	M16	240 N•m

Swing speed adjustment

Too fast swinging speed of clamp arm can cause malfunction. Adjust speed using flow control valve with check valve to set the swing time equal to or higher than the shortest swing time shown in the table below. Clamp stroke (perpendicular descend) time is not included in 90° swing time.

Clamp models	Shortest swing time	Max. flow rate	
		Clamping side	Unclamping side
CTW06 / CTV06	0.3 sec	0.43 ℓ / min	0.91 ℓ / min*
CTW10 / CTV10	0.3 sec	1.23 ℓ / min	2.41 ℓ / min*
CTW16 / CTV16	0.4 sec	1.48 ℓ / min	3.39 ℓ / min*
CTW25 / CTV25	0.4 sec	2.70 ℓ / min	5.60 ℓ / min*

* Only for the double-acting model CTW

Inertial moment for clamp arm

Too large inertial moment for clamp arm can also cause malfunction. When fabricating the clamp arm, determine a proper shape which provides inertial moment smaller than the maximum inertial moment shown in the table below.

Clamp models	Max. inertial moment
CTW06 / CTV06	1.6 × 10 ⁻³ kg•m ²
CTW10 / CTV10	5.1 × 10 ⁻³ kg•m ²
CTW16 / CTV16	8.5 × 10 ⁻³ kg•m ²
CTW25 / CTV25	1.4 × 10 ⁻² kg•m ²

Inertial moment for option clamp arm (reference)

Clamp arm models		Inertial moment
Standard type	CTH06-W1 / CTH06-W2	6.1 × 10 ⁻⁵ kg•m ²
	CTH10-W1 / CTH10-W2	2.6 × 10 ⁻⁴ kg•m ²
	CTH16-W1 / CTH16-W2	5.5 × 10 ⁻⁴ kg•m ²
	CTH25-W1 / CTH25-W2	1.14 × 10 ⁻³ kg•m ²
Long type	CTH06-WL	1.1 × 10 ⁻³ kg•m ²
	CTH10-WL	3.5 × 10 ⁻³ kg•m ²
	CTH16-WL	5.8 × 10 ⁻³ kg•m ²
	CTH25-WL	9.5 × 10 ⁻³ kg•m ²

Mounting of clamp and work support

Use screws with strength class of 12.9 for mounting clamp and work support and be sure to apply specified torque for tightening, by referring to recommended tightening torque of mounting screws indicated below.

Recommended tightening torque of mounting screws (strength class 12.9)

Mounting screw size	Tightening torque
M4 × 0.7	2.8 N·m
M5 × 0.8	7 N·m
M6 × 1	11 N·m
M8 × 1.25	25 N·m
M10 × 1.5	49 N·m
M12 × 1.75	60 N·m

Caution in use of equipment

1. Clamp and work supports have been developed for the purpose of clamping workpiece for machine tools. Do not use them for other purposes.
2. Always protect them with a cover to ensure sliding surfaces are not exposed to weld slags when using them as fixture for welding.
3. Clean sliding surfaces and top part of clamp body with air blowing periodically to ensure smooth operations.

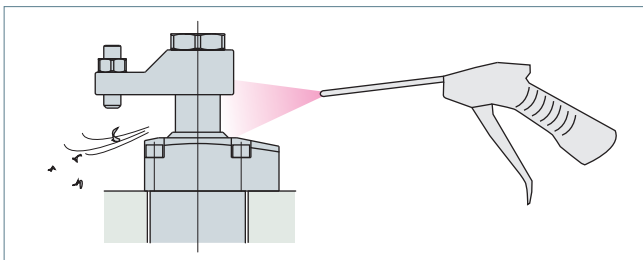

Mounting & dismounting of optional parts

1. When mounting or dismounting a flow control valve or air bleeding valve, be sure to set pressure within hydraulic circuit to 0 MPa before starting.
2. When mounting a flow control valve or air bleeding valve, be sure to tighten it with the specified tightening torque (refer to pages → 359 and 360 for recommended tightening torque).
3. When mounting a coolant cap (resin : POM), firmly press the body of cover. If it is not mounting properly, use a plastic mallet to tap it into place.
4. When dismounting a coolant cap, use a sharp-pointed tool such as a precision screw driver by hooking the notched portion.

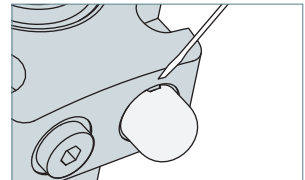

Caution for hydraulic piping

1. Most problems that occur with hydraulic equipment are caused by foreign substances such as metal chips and dust that enter into hydraulic circuits. Refer to "Piping Hydraulic & Pneumatic Equipment-Practical Notes" provided with the product for mounting and hydraulic piping of the product.
2. After performing hydraulic piping, always be sure to bleed out air in the hydraulic circuit. Insufficient bleeding can lead to malfunction.
3. When using multiple clamps, operating speeds and timings vary due to variance in pipe resistance and internal resistance of clamps. Adjust operating speeds and timings using flow control valve.
4. The special scraper has superior scraping capability to remove oil film on the surface of the rod, there are cases where grease and working fluids (oil films) inside the clamp are scraped and expelled to the outside. This may result in accumulation of oil in the external perimeters of piston rod on the upper part of the scraper, but this does not indicate an oil leak.

BSPB port sealing method

1. "Sealing method for flange surfaces" has been adopted as standard means for this product. Use fittings and connectors of bonded seal or elastic body seal. Do not use fittings of "Sealing method for tapered surfaces" (O-ring seal method).
2. Seal tapes and liquid packing are not necessary. Seal fittings with included with packing.
3. When mounting, clean metal chips and dust off surfaces that will come into contact with packing.

Sealing method for flange surfaces

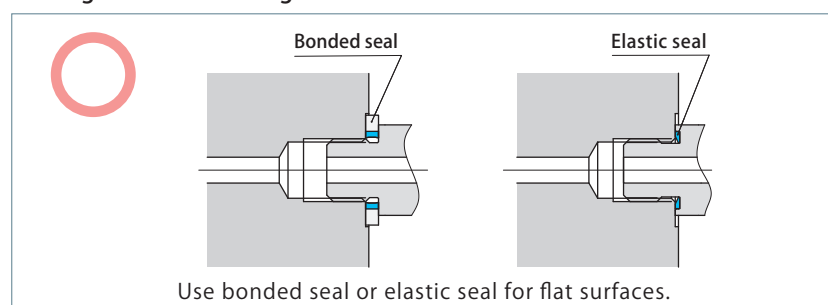

Sealing method for tapered surfaces

