

Double acting clamp is controlled and operated with control unit HCD□-W and coupling valve model VCB.



Control unit model **HCD₄-W**
page → 217



Coupling valve model **VCB**
pages → 203 and 204

Control unit (HCD4-W) converts air pressure (about 0.3MPa) to hydraulic pressure (6MPa) by actuation of air driven Pascal pump. Once circuit pressure is attained to the set pressure, it stops pumping then keeps the hydraulic pressure.

Coupling valve (VCB) is placed between a control unit and double acting clamps, and it allows to disconnect the control unit from the valve by means of hydraulic coupler. Built-in check valve in coupling valve can positively seal the pressure.

Clamping operation

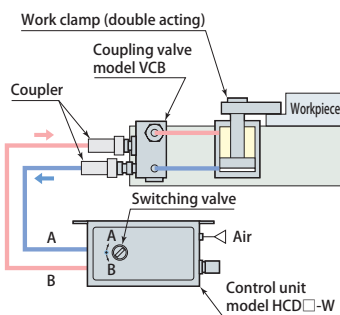

After coupler is connected, workpiece is clamped by aligning switching valve of control unit to B hydraulic connection port (clamping circuit).

Hydraulic pressure source disengagement (during processing)

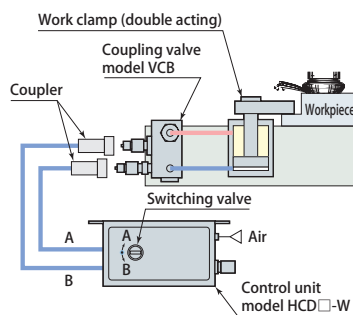

Coupler is released by aligning switching valve of control unit to center position after workpiece clamping is completed.

Unclamping operation

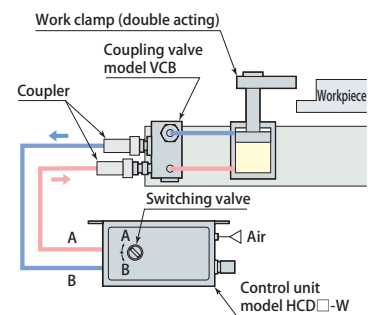

After coupler is connected, workpiece is taken out by unclamping, which is made possible by aligning switching valve of control unit to A hydraulic connection port (unclamping circuit).

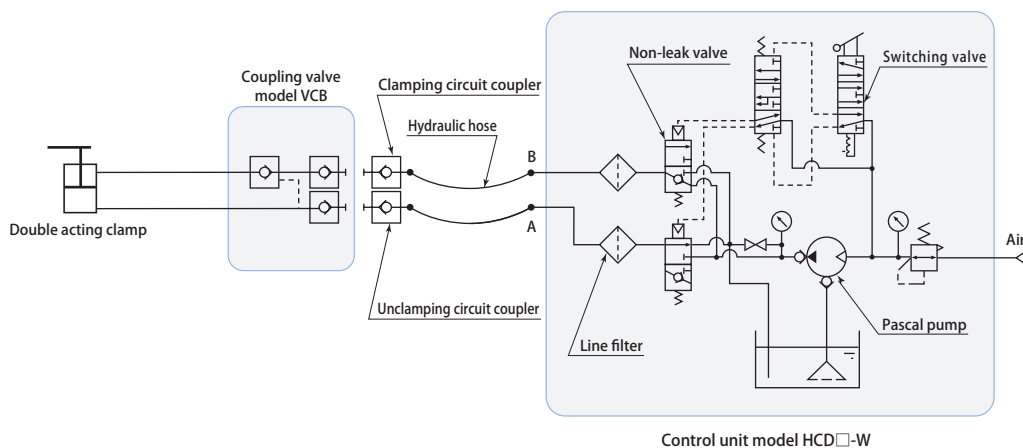

Control unit model HCD□-W

* Since Pascal pump does not raise oil temperature like electrical pumps, it does not trigger pressure drop (reduction in clamping force) after clamping due to difference between ambient temperature and oil temperature. Fluctuation of pressure due to changes in ambient temperature, however, does occur. (This fluctuation presents minimal problems with ordinary cutting processes. Inquire for details.)



Patented

Reducing valve model **VRG**
pages → 207 and 208

Internal hydraulic pressure of circuit can be partially reduced.
(Example) For work support 7 MPa (primary pressure)
pressure of work clamp is reduced to 3.5 MPa.

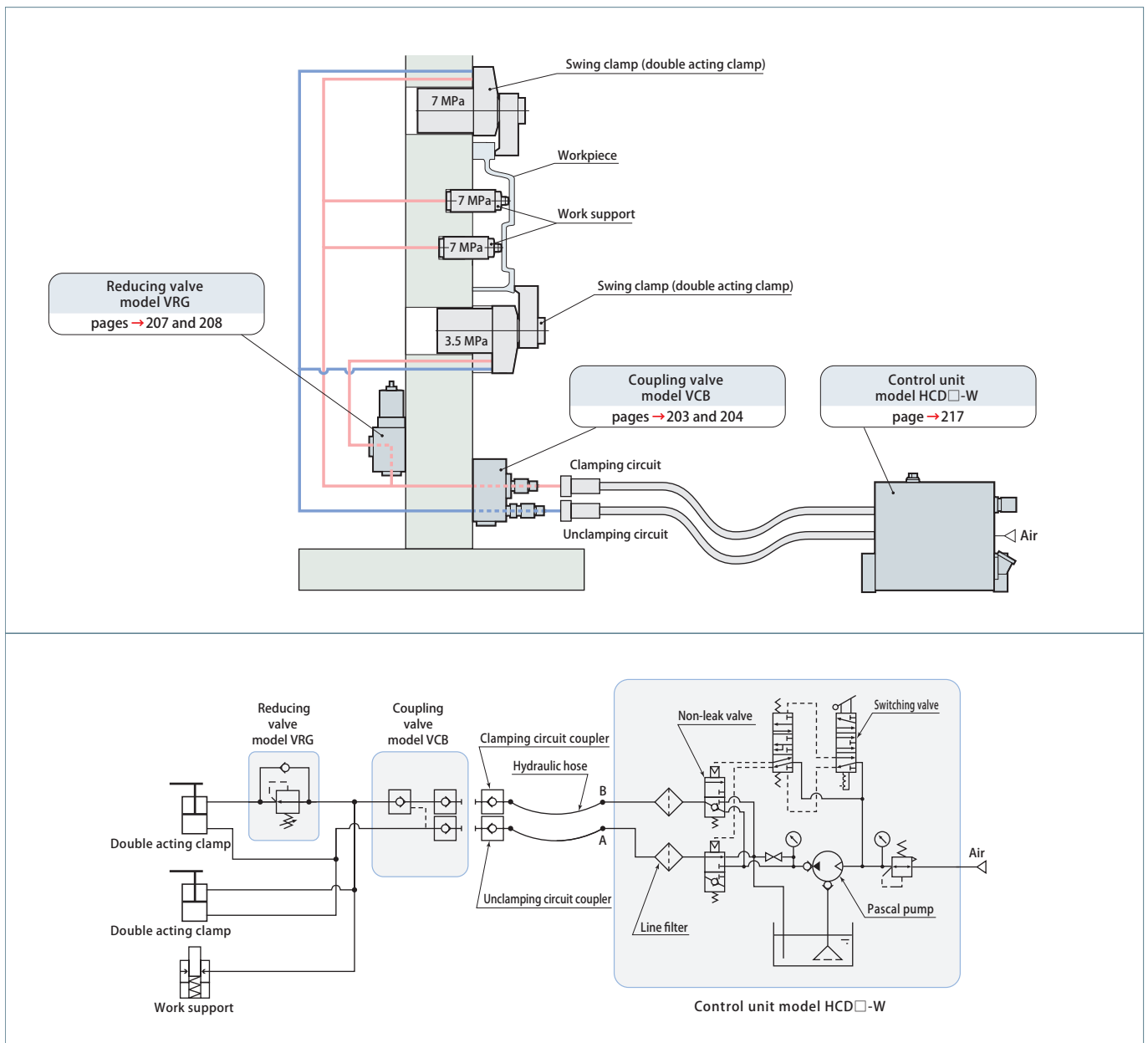

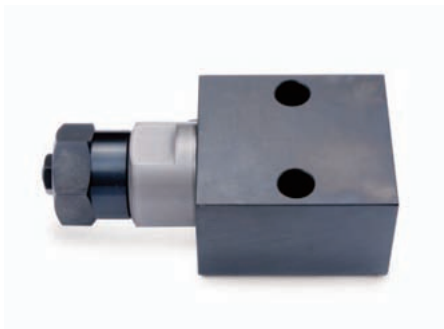

Sequence valve model **VED**
pages → 209 and 210

Work clamp and work support are sequentially operated through same circuit.

- (Example) ① After operating work support lock
② Work clamp operation performed.

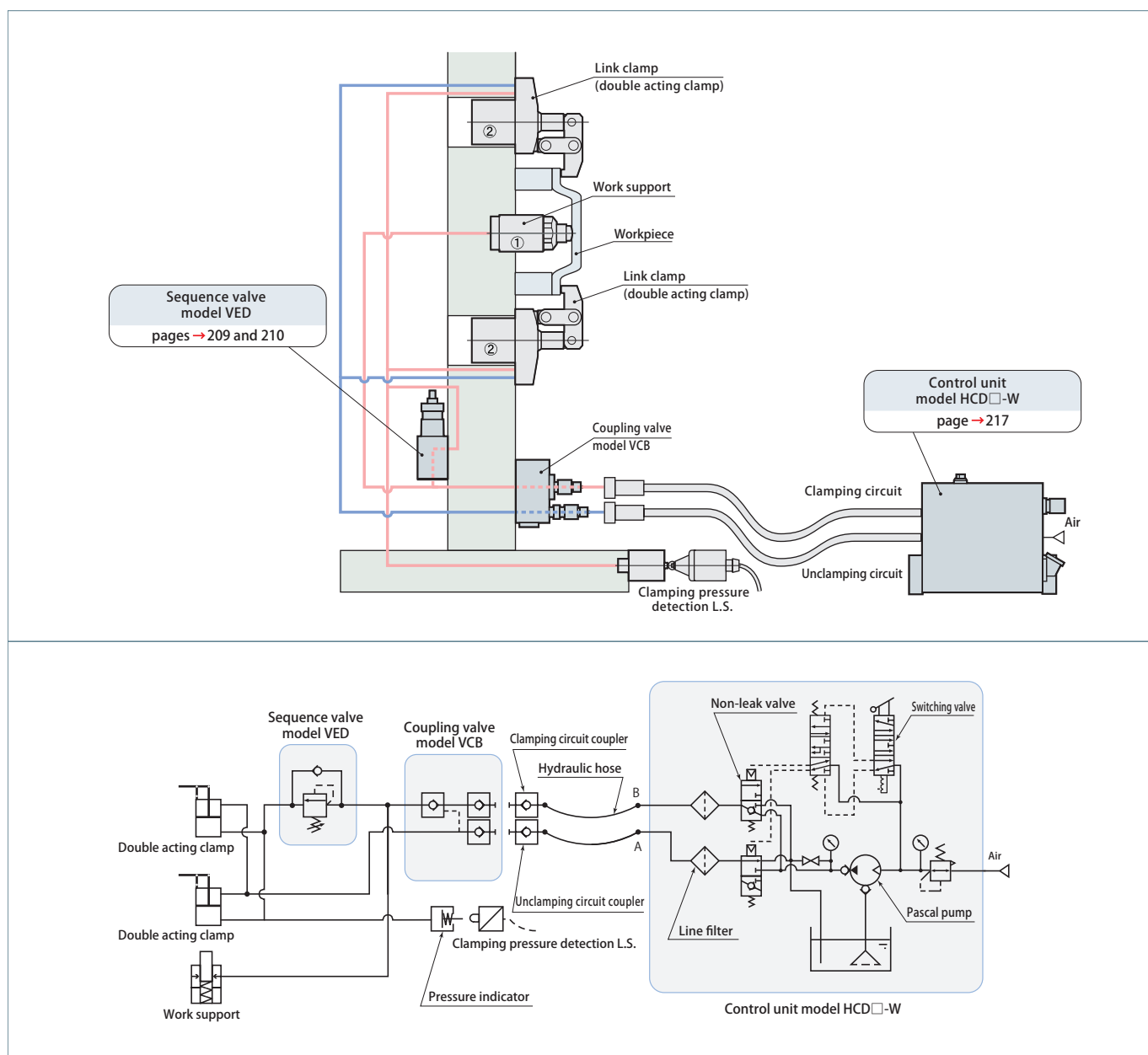

Accumulator model **WPB • WPC**

pages → 211 to 216

After hydraulic pressure source has been disengaged, circuit pressure fluctuation due to temperature changes is suppressed.

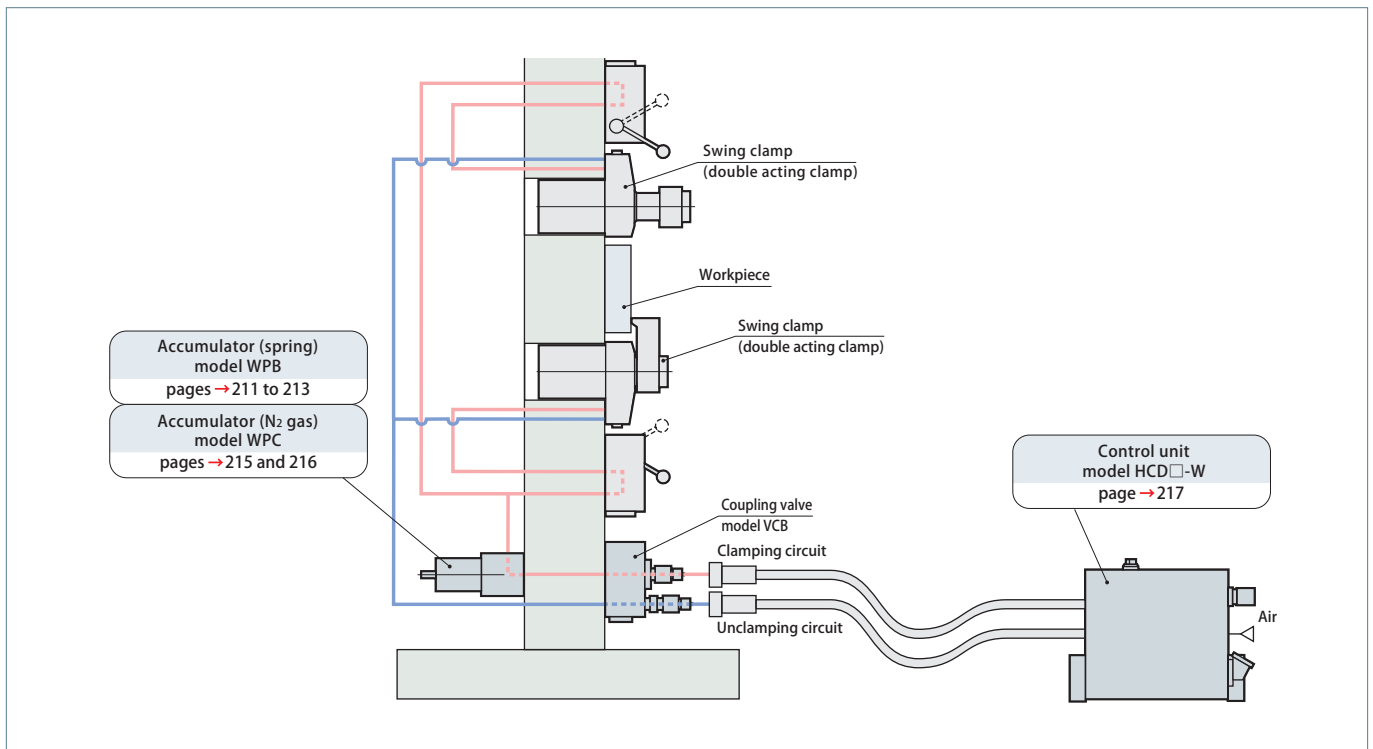

⚠ Cautions

When using double acting swing clamps, be sure to perform unclamping operation on all clamps at the same time.

Exerting hydraulic pressure to unclamping side while keeping clamping circuit of some clamps closed with two-way valve results in exertion of abnormal pressure on clamping side, which causes malfunction. Clamping operation can be performed for each individual clamp.

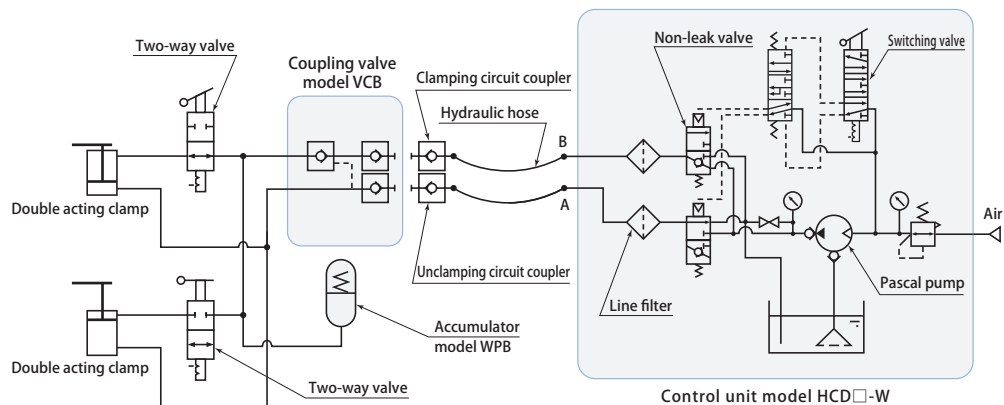

Single acting clamp is controlled and operated with control unit model HCD□-S and coupling valve model VHD.



Control unit model **HCD₄-S**
page → 218



Coupling valve model **VHD**
pages → 205 and 206

Control unit (HCD4-S) converts air pressure (about 0.3MPa) to hydraulic pressure (6MPa) by actuation of air driven Pascal pump. Once circuit pressure is attained to the set pressure, it stops pumping then keeps the hydraulic pressure.

Coupling valve (VHD) is placed between a control unit and single acting clamps, and it allows to disconnect the control unit from the valve by means of hydraulic coupler. Built-in check valve in coupling valve can positively seal the pressure.

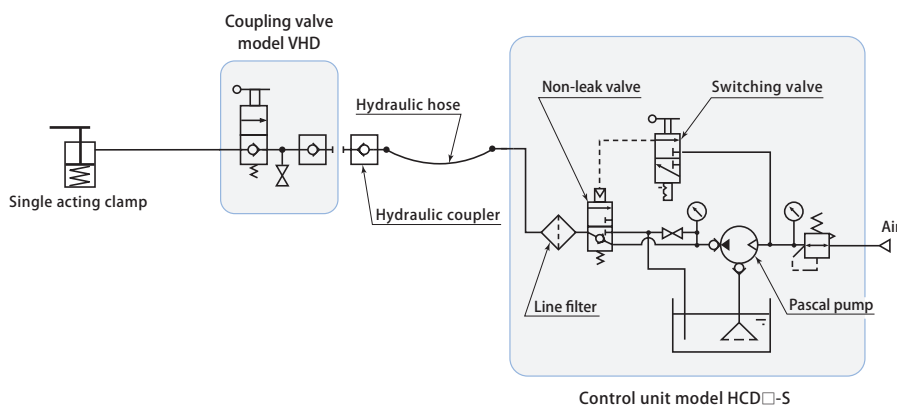
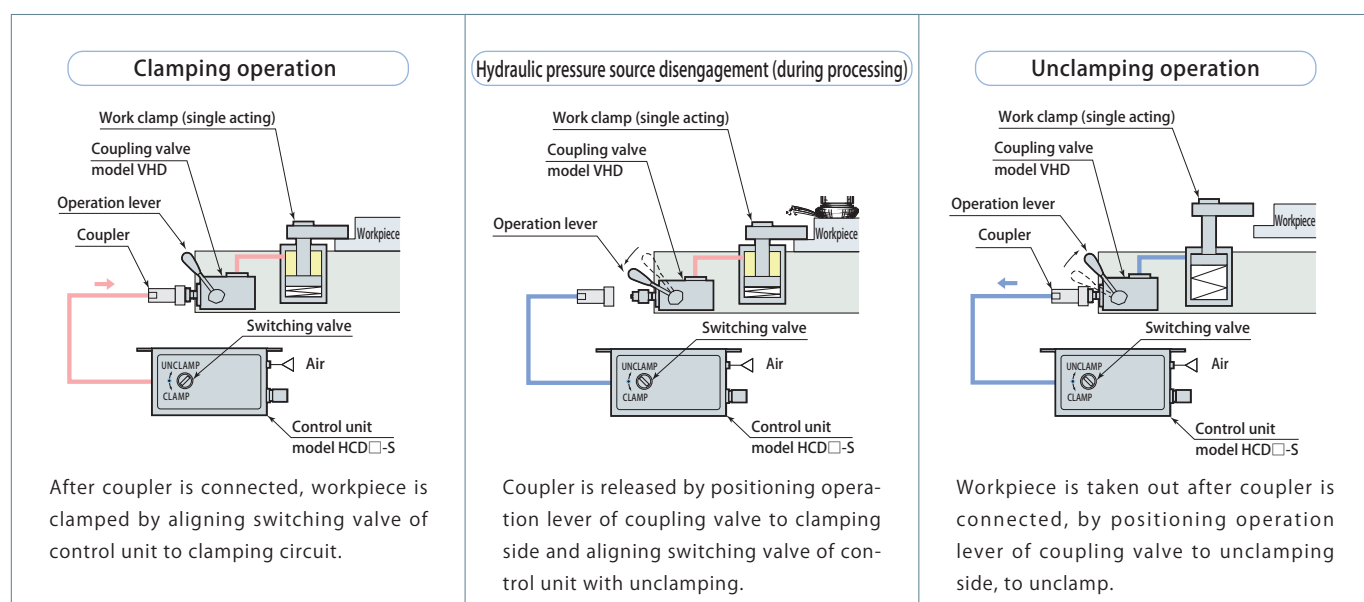

* Since Pascal pump does not raise oil temperature like electrical pumps, it does not trigger pressure drop (reduction in clamping force) after clamping due to difference between ambient temperature and oil temperature. Fluctuation of pressure due to changes in ambient temperature, however, does occur. (This fluctuation presents minimal problems with ordinary cutting processes. Inquire for details.)



Control unit model **HCT**
page → 219



Reducing valve model **VRG**
pages → 207 and 208

Patented

Compact hydraulic control unit for air drive and manual operations. Control unit (HCT-4) converts air pressure (about 0.3MPa) to hydraulic pressure (6MPa) by actuation of air driven Pascal pump. Once circuit pressure is attained to the set pressure, it stops pumping then keeps the hydraulic pressure.

Internal hydraulic pressure of circuit can be partially reduced. (Example) For work support 7 MPa (primary pressure) pressure of work clamp is reduced to 3.5 MPa.

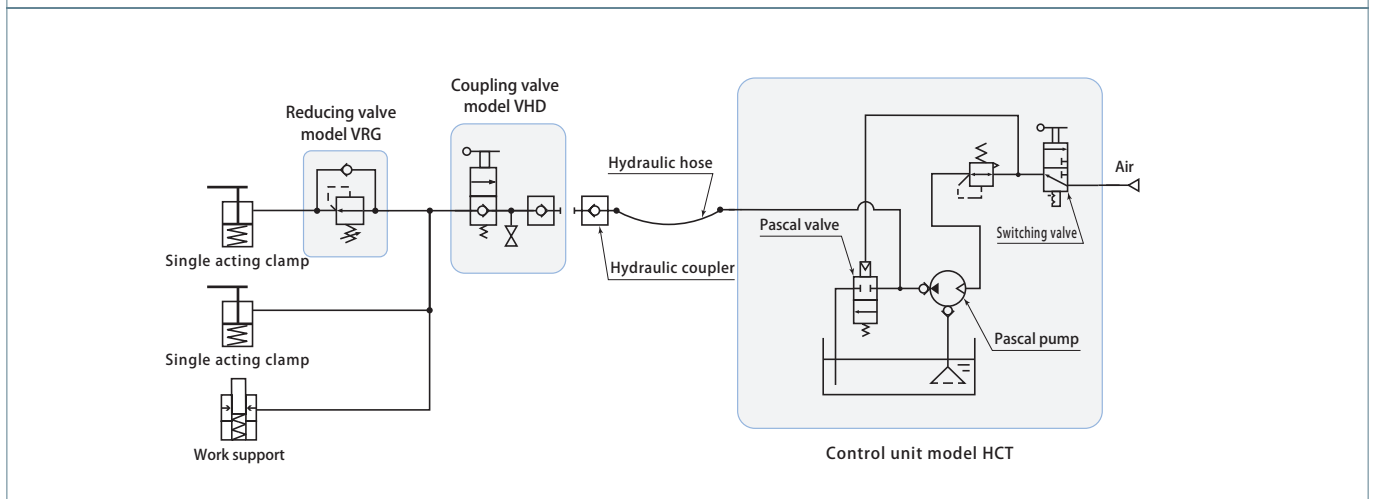
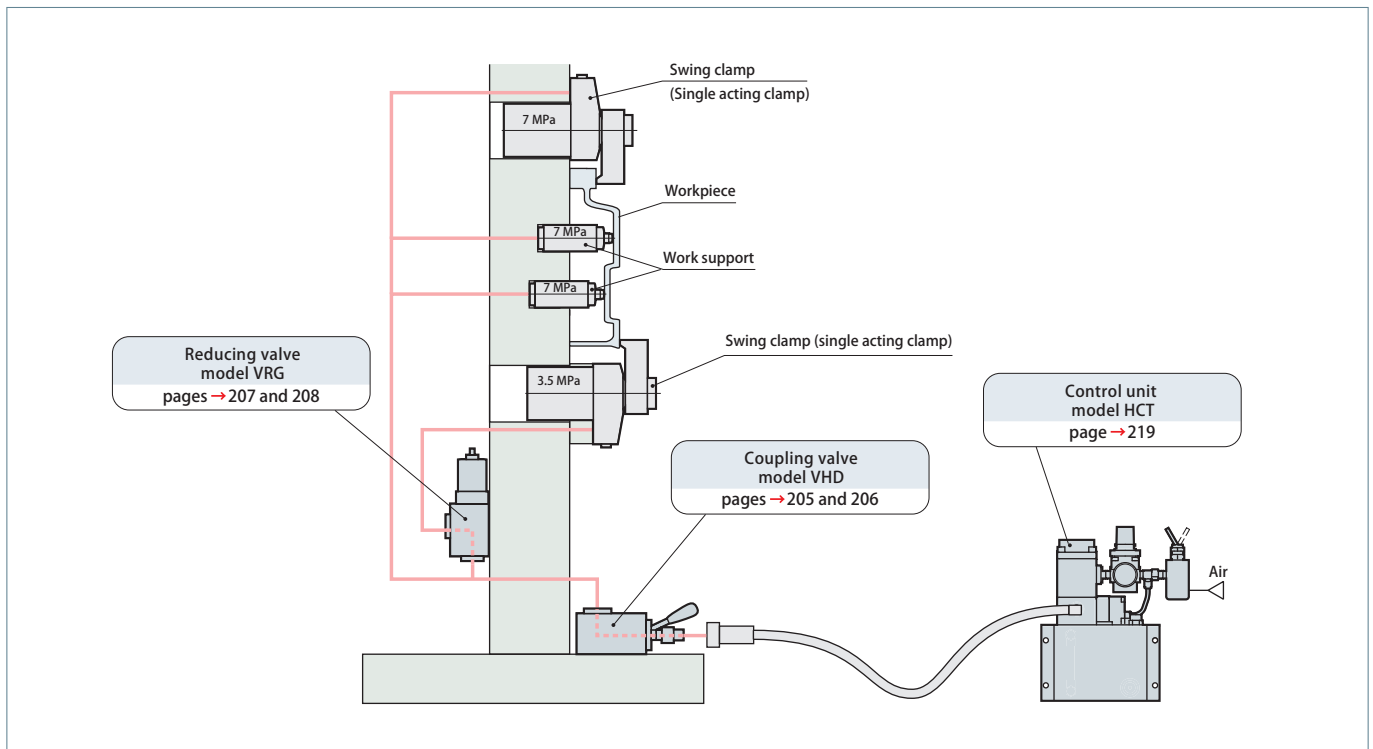



Sequence valve model **VED**
pages → 209 and 210

Work clamp and work support are sequentially operated through same circuit.

(Example) ① After operating work support lock

② Work clamp operation performed.

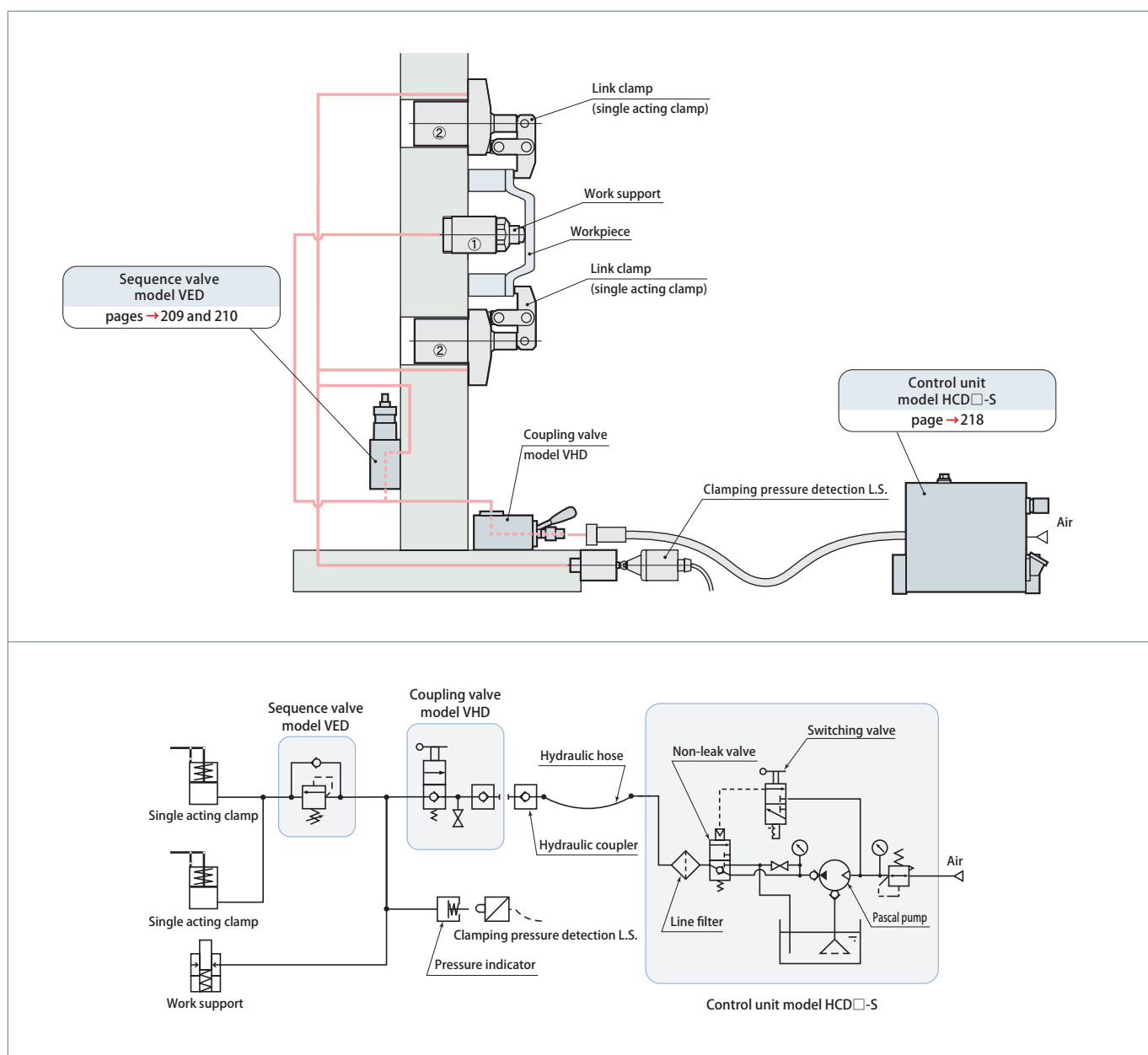

Accumulator model **WPB • WPC**

pages → 211 to 216

After hydraulic pressure source has been disengaged, circuit pressure fluctuation due to temperature changes is suppressed.

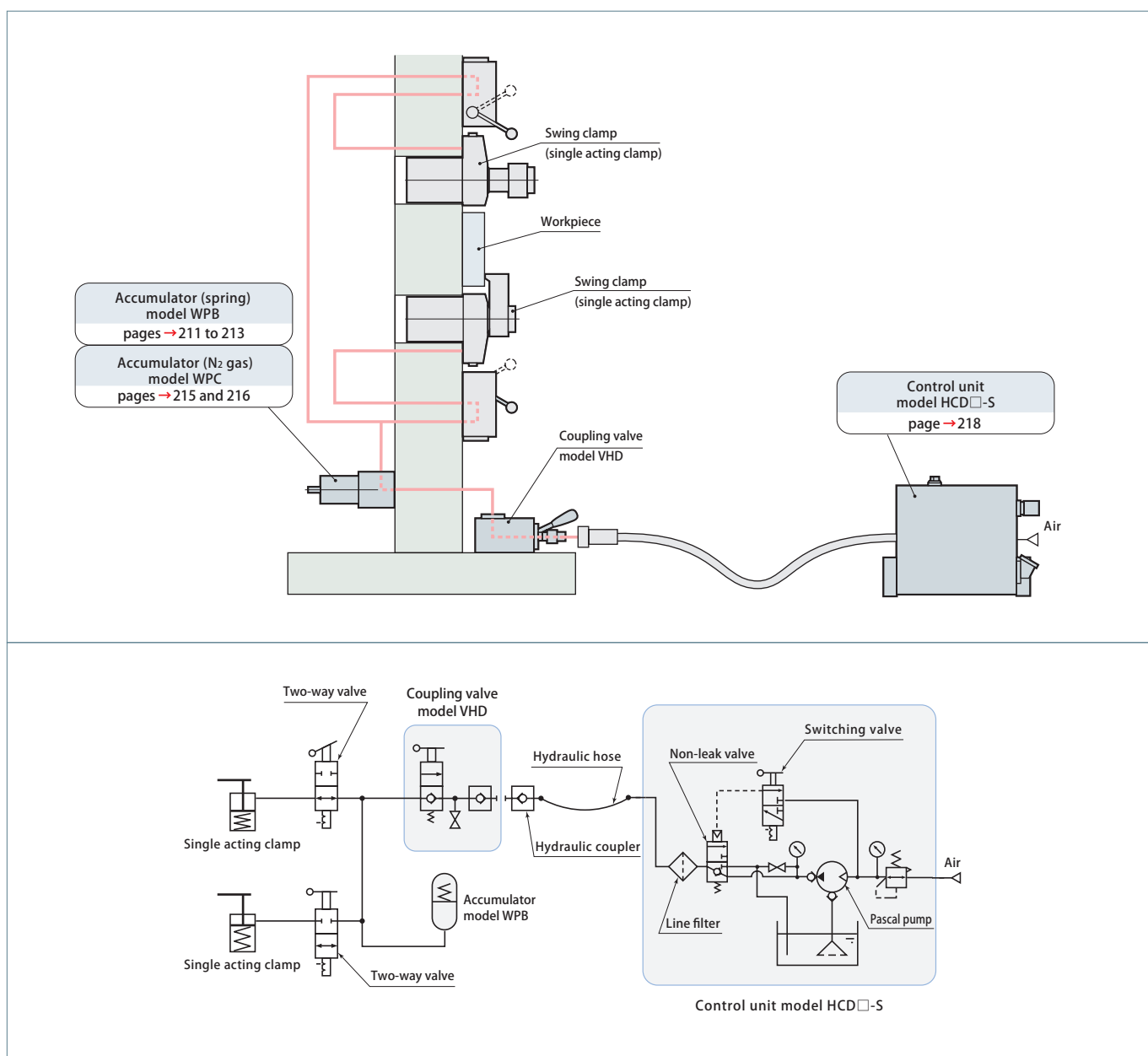



Coupling valve model **VCB**

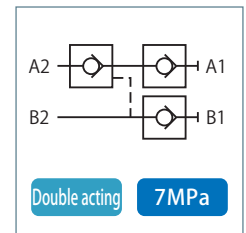
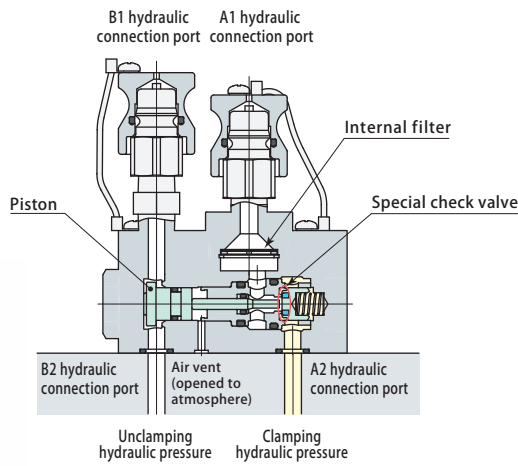

This is a non-leak valve, with which coupling of double acting clamp can be performed easily and clamping circuit pressure can be retained over a long period of time after disengagement of hydraulic pressure source.

Specifications

Model	VCB-LGB	VCB-LGS	VCB-LT
Mounting/piping methods	Manifold, Bottom mounting	Manifold, Side mounting	Piping mounting
Working pressure range (MPa)	2 ~ 7		
Proof pressure (MPa)	10.5		
Min. pilot pressure (open valve) (MPa)	0.3 + 0.23 × secondary side pressure		
Orifice area (mm ²)	14.2		
Operating temperature (°C)	0 ~ 70		
Fluid used	General mineral based hydraulic oil (ISO-VG32 equivalent)		
Mass (kg)	1.4		

There is also a type that adopts fluorocarbon for seal sections where cutting fluid is applied, as a measure for the use of chlorine-based cutting fluid (this is not thermal resistant specification. Model designation VCB-□□□-V).

Dimensions

VCB-LGB Manifold, Bottom mounting * With internal filter (A1 hydraulic connection port)

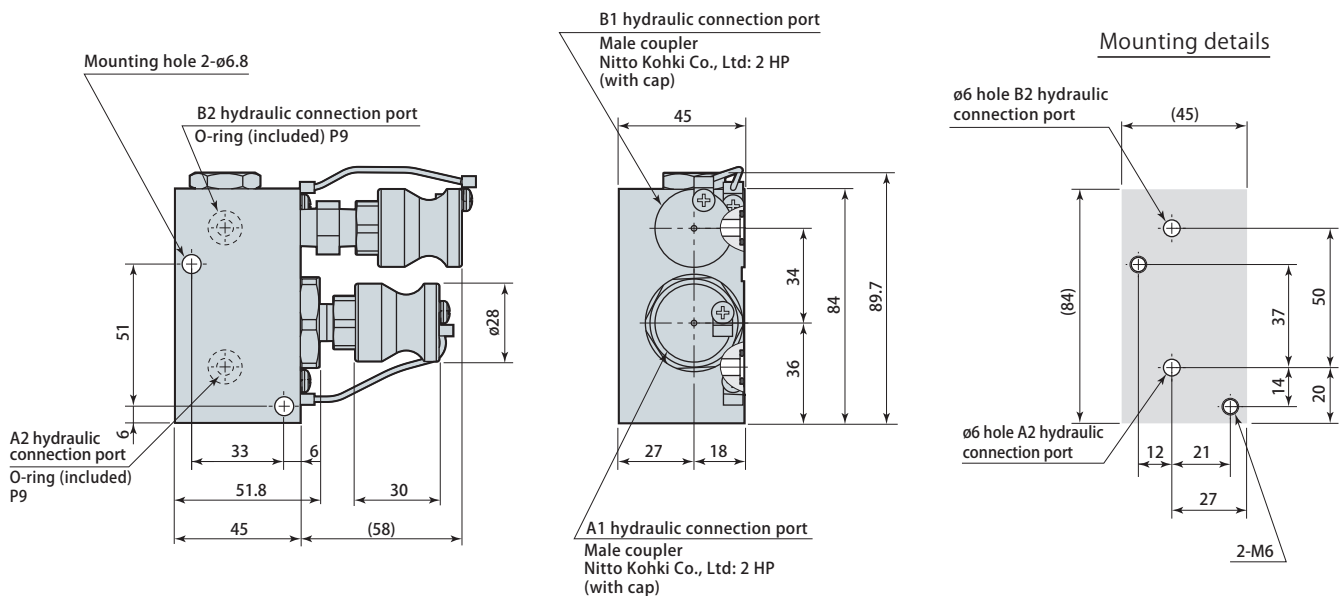

For the purpose of manifold piping, the mounting surface finish must be no rougher than Rz 6.3 (ISO4287:1997).

Dimensions

VCB-LGS Manifold, Side mounting * With internal filter (A1 hydraulic connection port)

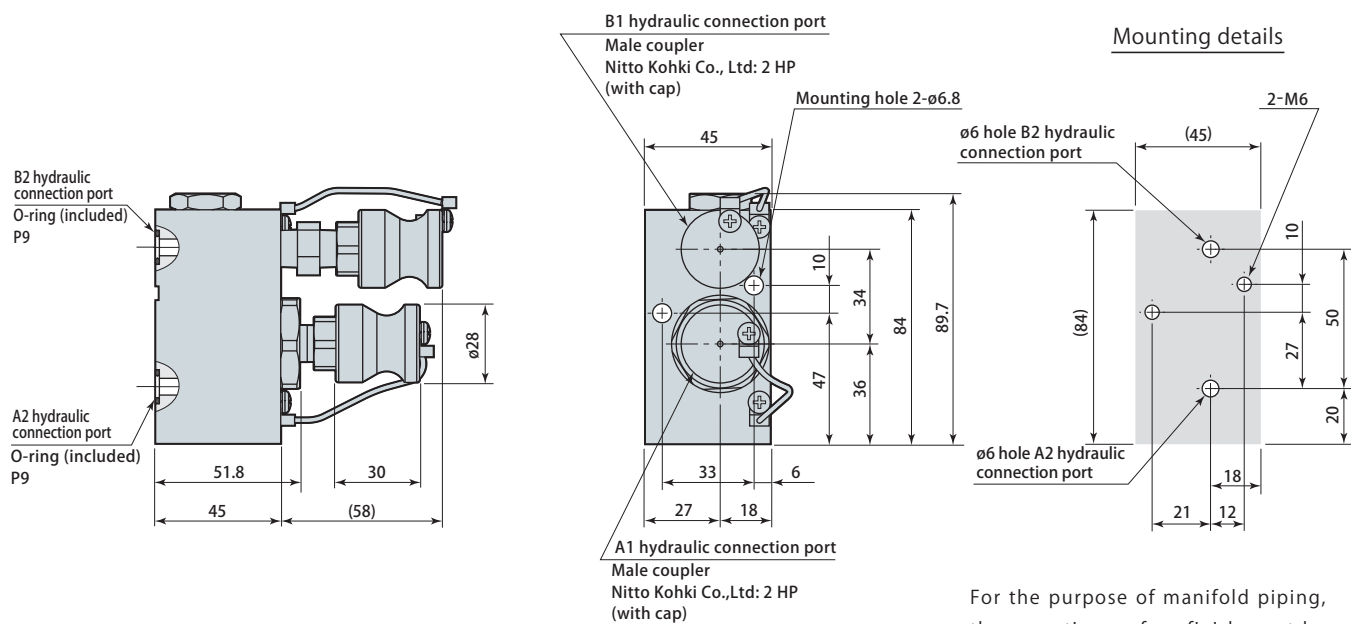

For the purpose of manifold piping, the mounting surface finish must be no rougher than Rz 6.3 (ISO4287:1997).

VCB-LT Piping mounting * With internal filter (A1 & A2 hydraulic connection ports)

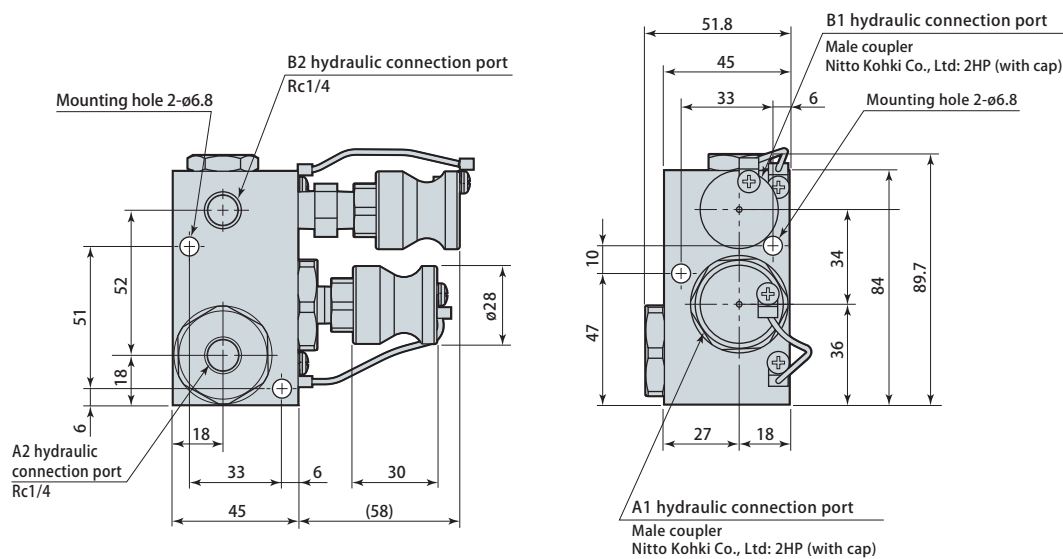

Female coupler and mounting screws are not included.

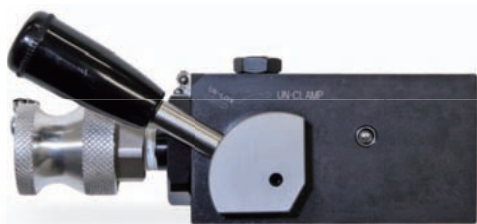

Coupling valve model **VHD**

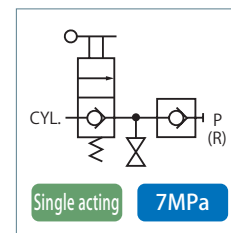
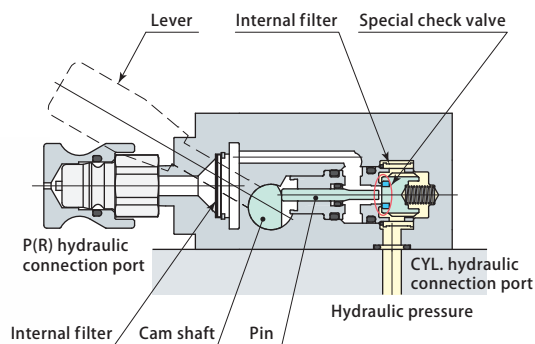

This is a non-leak valve, with which coupling of single acting clamp can be performed easily and clamping circuit pressure can be retained over a long period of time after disengagement of hydraulic pressure source.

Specifications

Model	VHD-LGB	VHD-LGS	VHD-LT
Mounting/piping methods	Manifold, Bottom mounting	Manifold, Side mounting	Piping mounting
Working pressure range (MPa)	2 ~ 7		
Proof pressure (MPa)	10.5		
Cracking pressure (MPa)	0.017		
Orifice area (mm ²)	21.2		
Operating temperature (°C)	0 ~ 70		
Fluid used	General mineral based hydraulic oil (ISO-VG32 equivalent)		
Mass (kg)	1.4		

There is also a type that adopts fluorocarbon for seal sections where cutting fluid is applied, as a measure for the use of chlorine-based cutting fluid (this is not thermal resistant specification. Model designation VHD-□□□-V).

Dimensions

VHD-LGB

Manifold, Bottom mounting

* With internal filter (P & CYL. hydraulic connection ports)

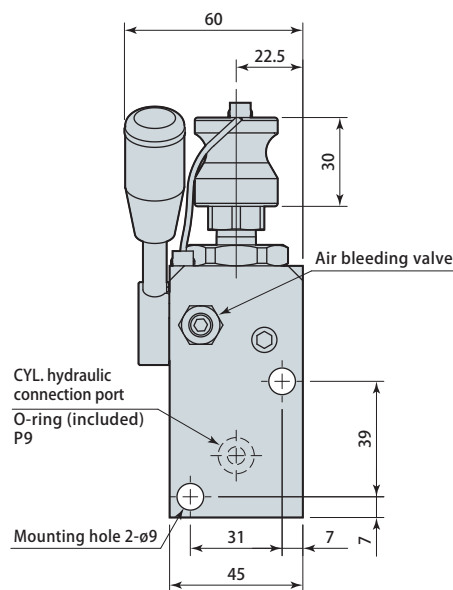
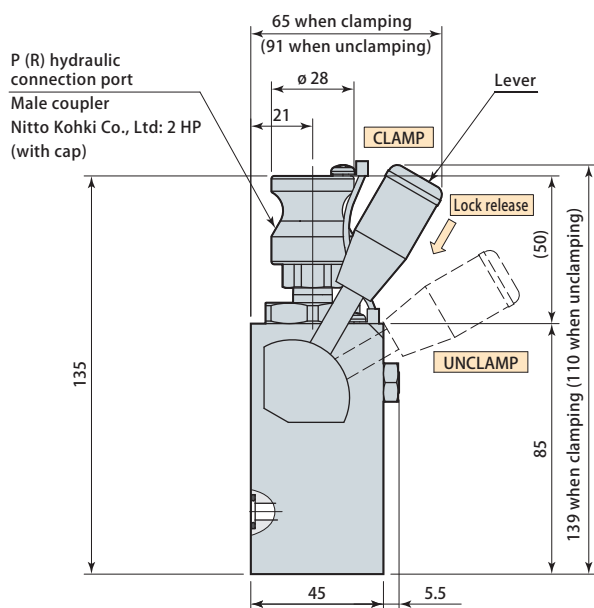

Mounting details

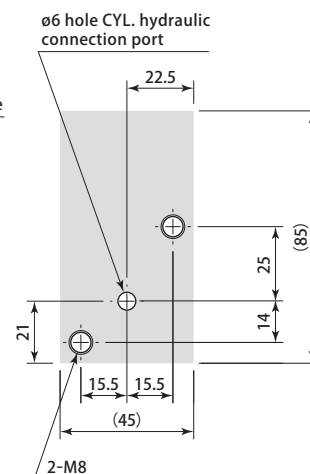

UNCLAMP operation

1. Press in lever to release lock.
2. Pull lever while pressed to UNCLAMP.
3. Release lever and it will return to CLAMP position.

For the purpose of manifold piping, the mounting surface finish must be no rougher than Rz6.3 (ISO4287:1997).

Dimensions

VHD-LGS Manifold, Side mounting

* With internal filter (P & CYL. hydraulic connection ports)

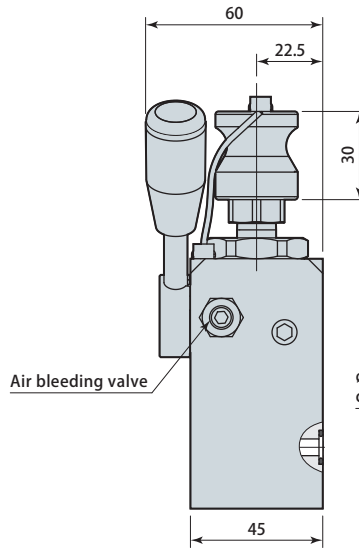
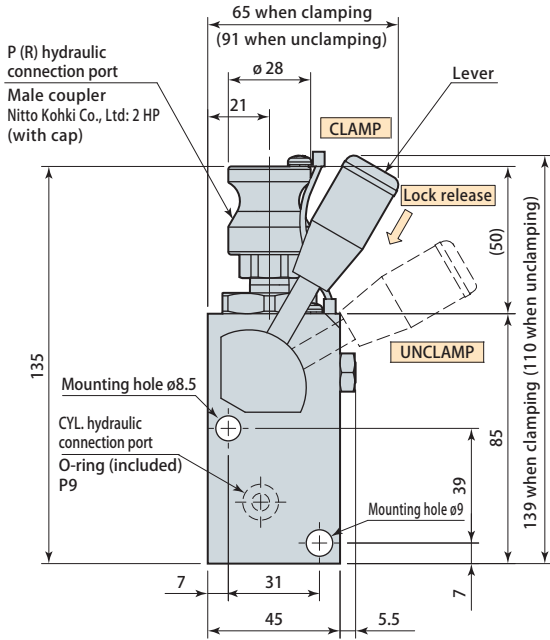

Mounting details

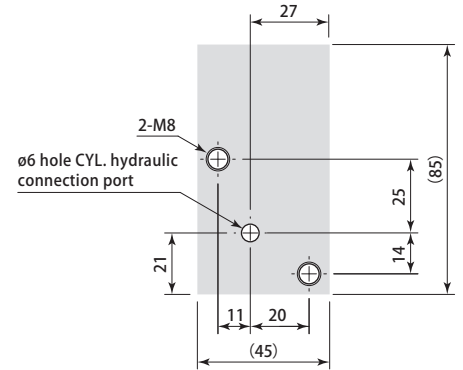

UNCLAMP operation

1. Press in lever to release lock.
2. Pull lever while pressed to UNCLAMP.
3. Release lever and it will return to CLAMP position.

For the purpose of manifold piping, the mounting surface finish must be no rougher than Rz6.3 (ISO4287:1997).

VHD-LT Piping mounting

* With internal filter (P & CYL. hydraulic connection ports)

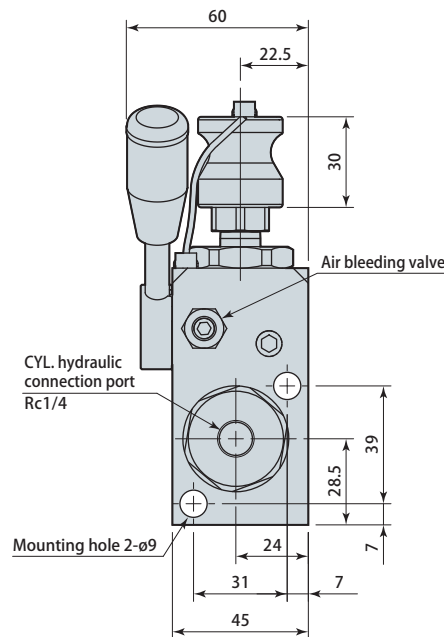
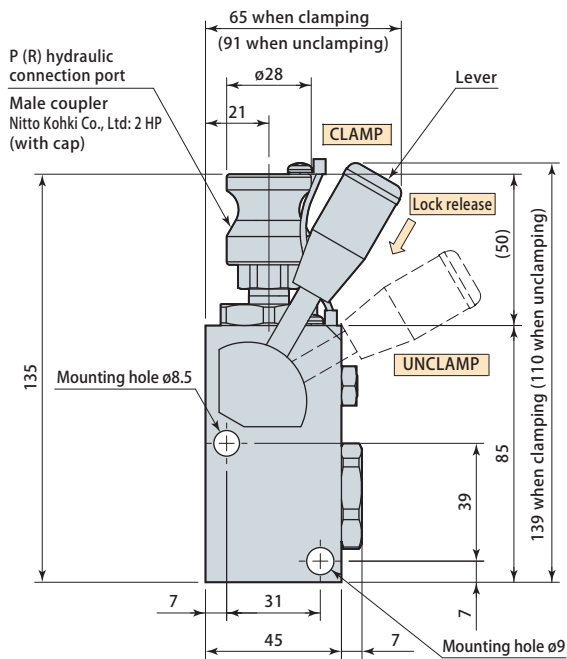

UNCLAMP operation

1. Press in lever to release lock.
2. Pull lever while pressed to UNCLAMP.
3. Release lever and it will return to CLAMP position.

Female coupler and mounting screws are not included.

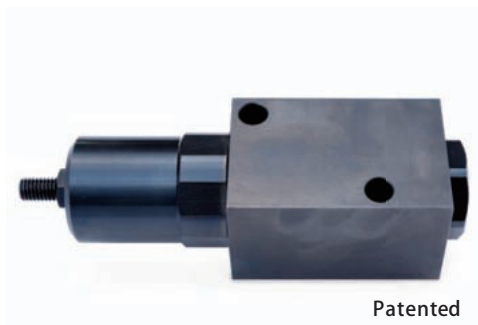

Patented

Reducing valve model **VRG**

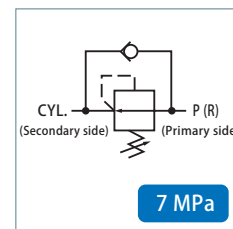
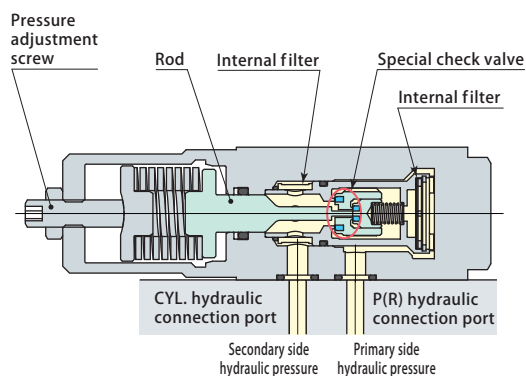

Internal hydraulic pressure of circuit can be partially reduced. This is a non-leak type that requires no drain.

Specifications

Model	VRG-LG	VRG-LT	VRG-LS
Mounting/piping methods	Manifold mounting	Piping mounting	VHD linking
Primary side hydraulic pressure range (MPa)		2 ~ 7	
Secondary side hydraulic pressure range (MPa)		1 ~ 6	
Allowable min. differential pressure* (MPa)		1	
Proof pressure (MPa)		10.5	
Pressure change per revolution (MPa/rev)		0.5	
Orifice area (mm ²)		28.1	
Operating temperature (°C)		0 ~ 70	
Fluid used	General mineral based hydraulic oil (ISO-VG32 equivalent)		
Mass (kg)	0.9	1.0	1.0

Fluorocarbon has been adopted for seal sections where cutting fluid is applied, as a measure for the use of chlorine-based cutting fluid (this is not thermal resistant specification).

*: The setting should be performed so that the differential pressure between primary side hydraulic pressure and secondary side hydraulic pressure may exceed 1 MPa. (Example: If primary side hydraulic pressure is 5 MPa, secondary side hydraulic pressure should be from 1 ~ 4 MPa.)

Dimensions

VRG-LG Manifold mounting * With internal filter (P & CYL. hydraulic connection ports)

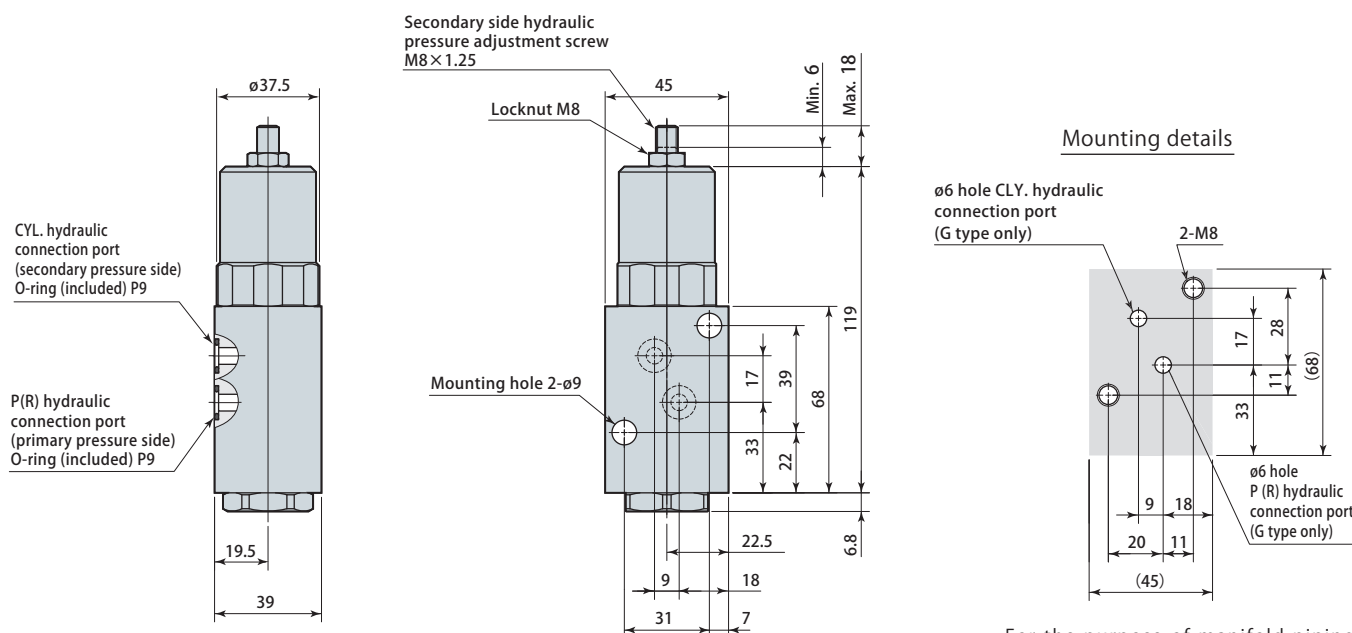

For the purpose of manifold piping, the mounting surface finish must be no rougher than Rz 6.3 (ISO4287:1997).

Dimensions

VRG-LT Piping mounting * With internal filter (P & CYL. hydraulic connection ports)

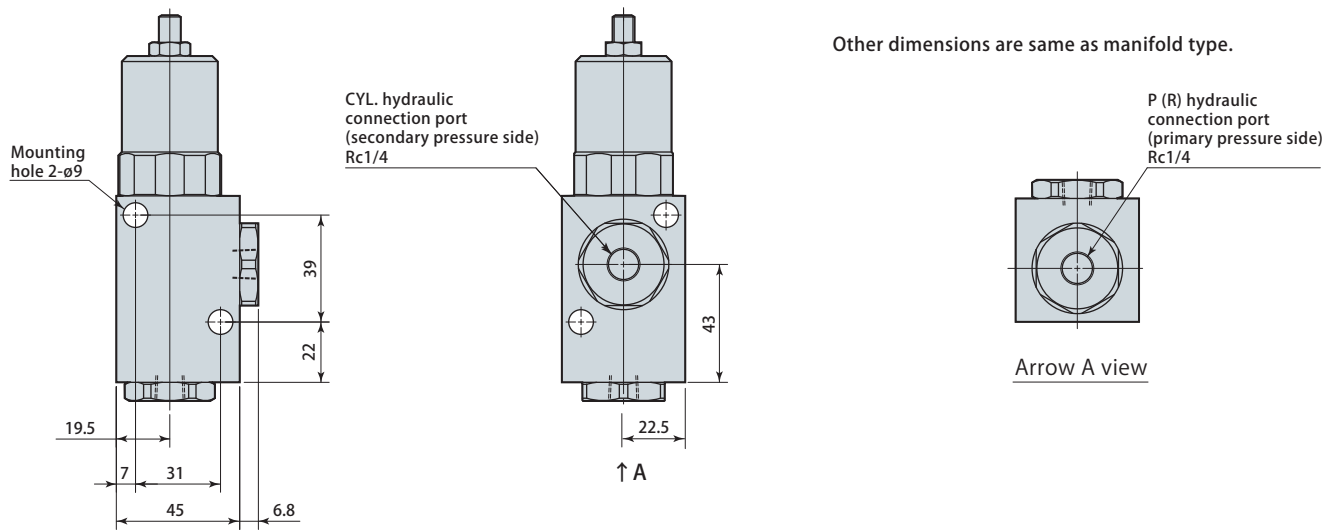

VRG-LS VHD linking * With internal filter (P & CYL. hydraulic connection ports)

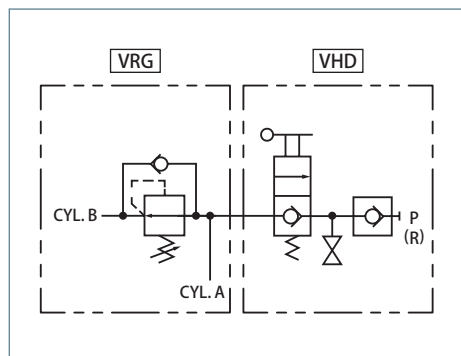
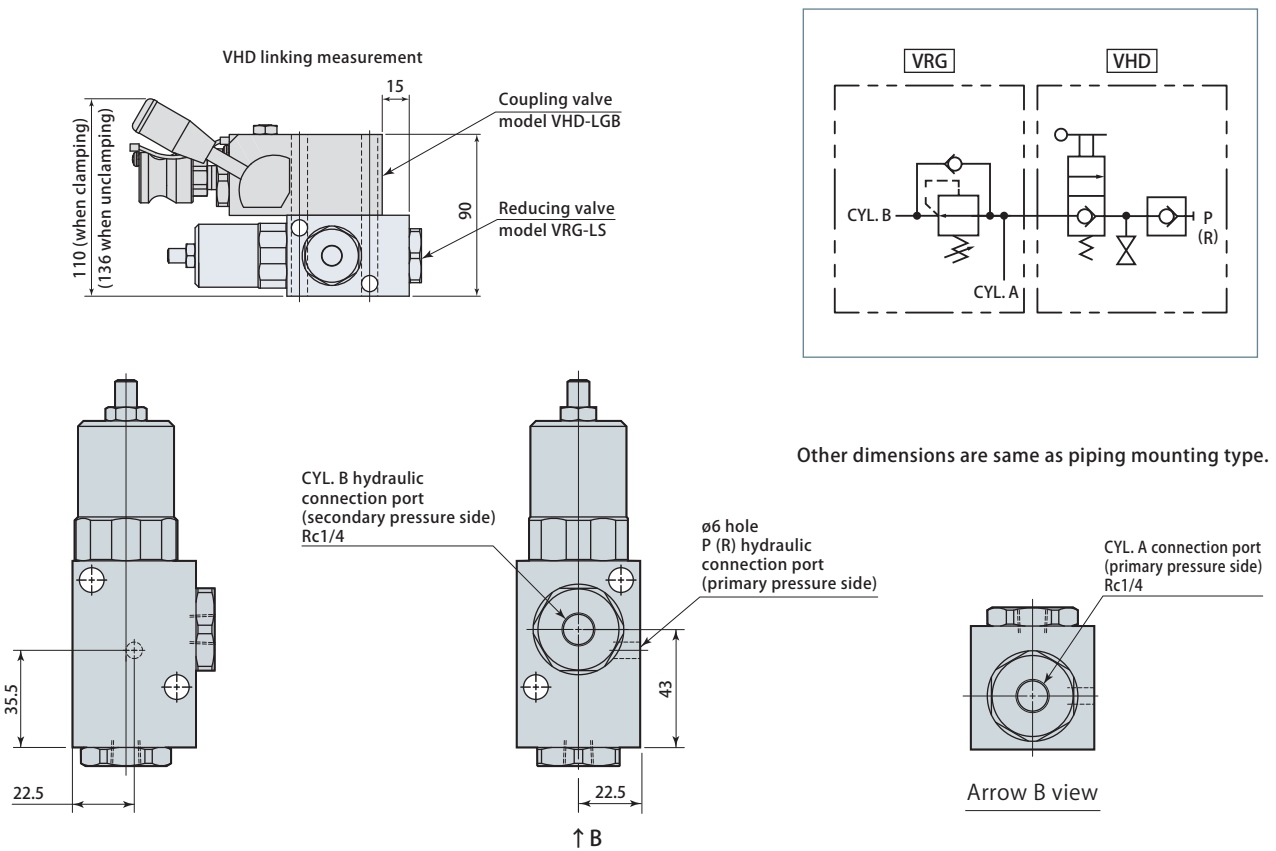

Note 1. Structure is such that when pressure on secondary side (low pressure side) drops due to temperature change or oil leak, flow channel to primary side (high pressure side) is opened to replenish oil until pressure reaches set pressure.

2. Pressure is not supplemented when primary side is separated from hydraulic pressure source.

Note 3. Mounting screws are not included.



Sequence valve model **VED**

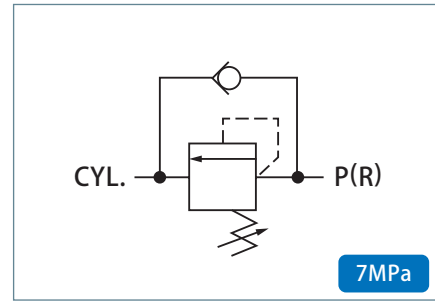

Work clamp and work support are sequentially operated through same circuit.

Specifications

Model	VED-LG	VED-LT	VED-LA	VED-LB
Mounting/piping methods	Manifold mounting	Piping mounting	VHD linking, Manifold mounting	VHD linking, Piping mounting
Working pressure range (MPa)	2 ~ 30			
Allowable min. differential pressure* (MPa)	1			
Set hydraulic pressure range (MPa)	1 ~ 6			
Cracking pressure (MPa)	0.015			
Pressure change per revolution (MPa/rev)	1			
Orifice area (mm ²)	28.3			
Mass (kg)	0.6		0.9	

Proof pressure: 37.5 MPa Operating temperature: 0 ~ 70°C Fluid used: General mineral based hydraulic oil (ISO-VG32 equivalent)
 There is also a type that adopts fluorocarbon for seal sections where cutting fluid is applied, as a measure for the use of chlorine-based cutting fluid (this is not thermal resistant specification. Model designation VED-□□-V).

*:The setting should be performed so that the differential pressure between working pressure and set hydraulic pressure may exceed 1 MPa. (Example: If working pressure is 5 MPa, set hydraulic pressure should be from 1 ~ 4 MPa.)

Dimensions

VED-LG Manifold mounting * With internal filter (P & CYL. hydraulic connection ports)

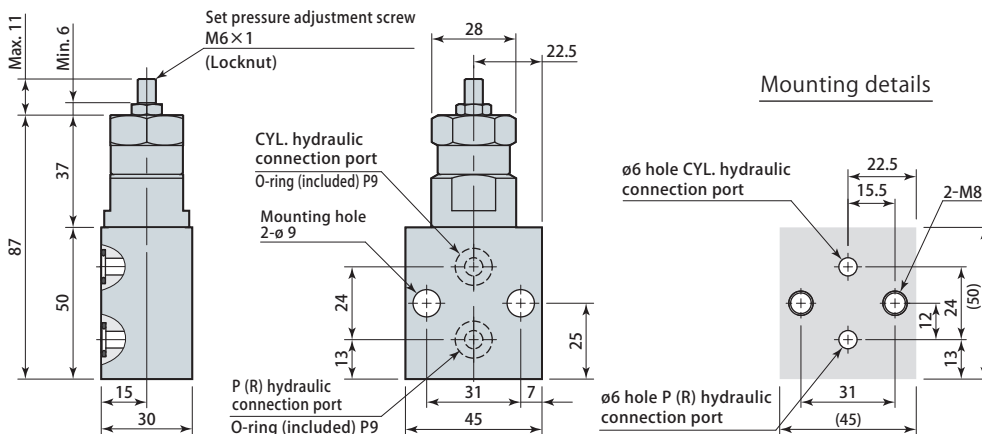

For the purpose of manifold piping, the mounting surface finish must be no rougher than Rz6.3 (ISO4287:1997).

VED-LT Piping mounting * With internal filter (P & CYL. hydraulic connection ports)

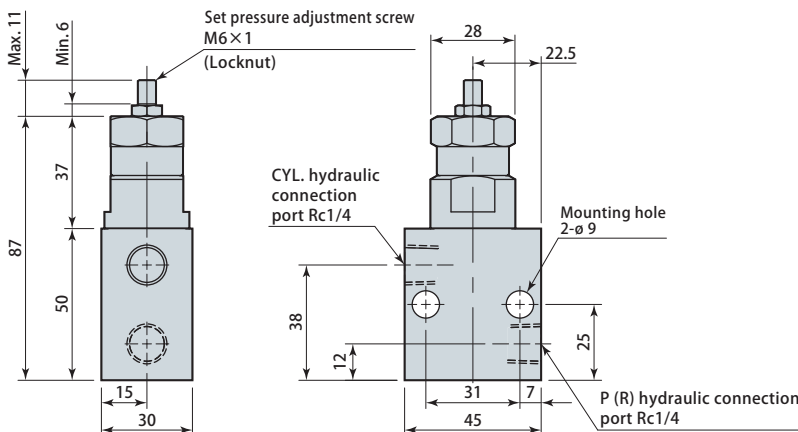

Dimensions

VED-LA VHD linking, Manifold mounting

* With internal filter (P & CYL. hydraulic connection ports)

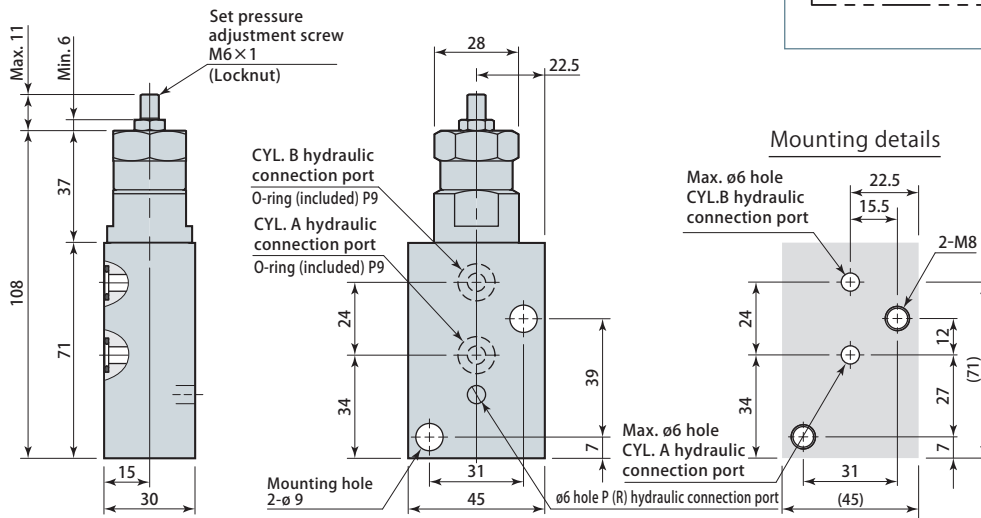
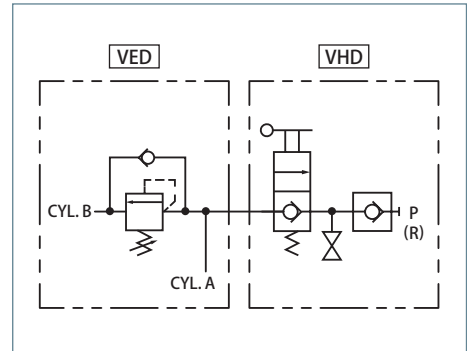
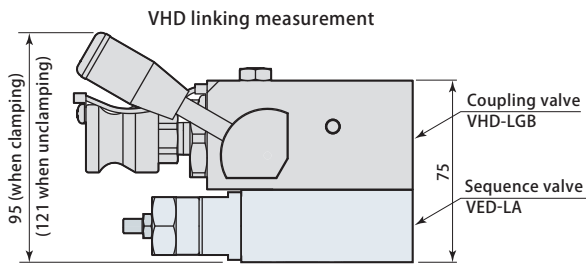

For the purpose of manifold piping, the mounting surface finish must be no rougher than Rz6.3 (ISO4287:1997).

VED-LB VHD linking, Piping mounting

* With internal filter (P & CYL. hydraulic connection ports)

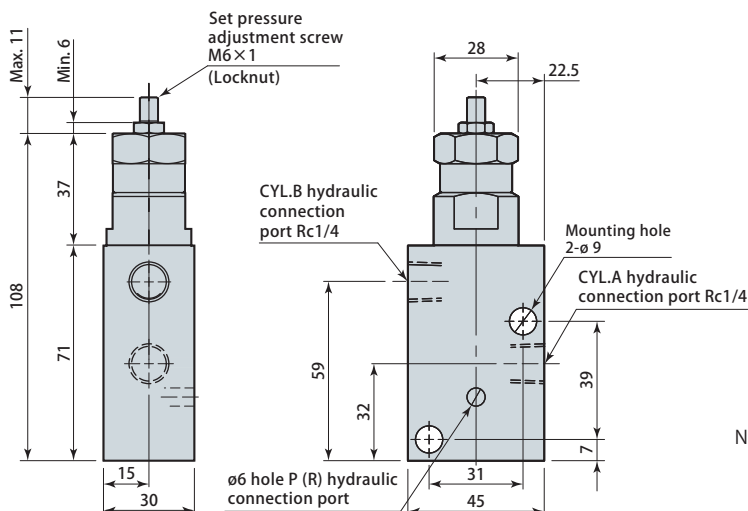
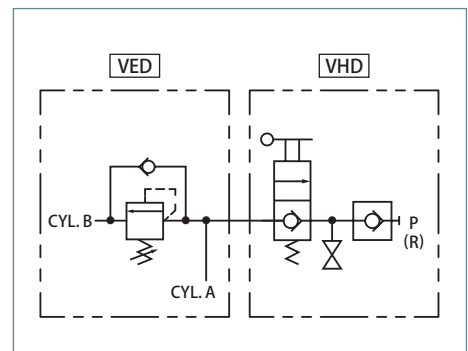
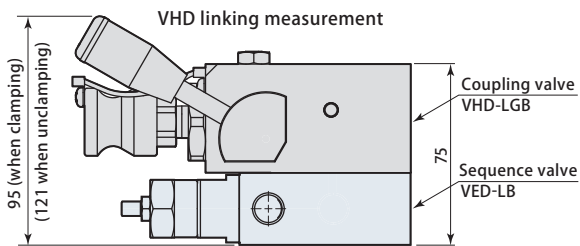

Note 1. Mounting screws are not included.

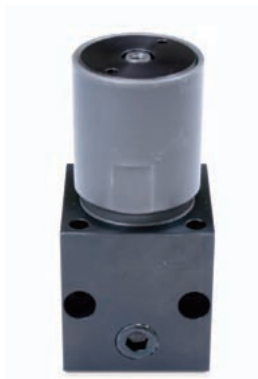

Accumulator model **WPB**

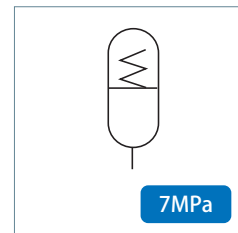
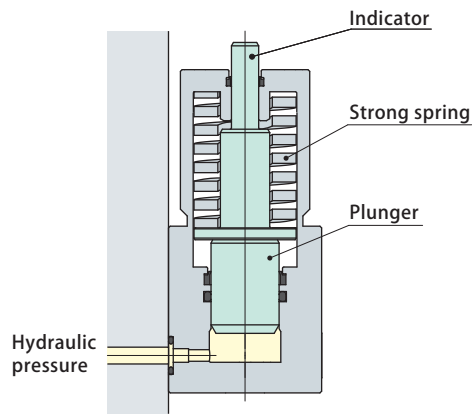

Spring pressure type accumulator.
Pressure fluctuation that occurs due to temperature change after disengaging hydraulic pressure source is suppressed.

Model designation

WPB ①-②③-④ (Example : WPB3-2GB-V)

① Symbol (refer to specification table)

② Oil discharge/absorption amount

③ Mounting method

④ Variation code

WPB	2	-	1 : 3.3 cm ³ 2 : 6.6 cm ³ 3 : 13 cm ³	GS : Manifold, Side mounting GB : Manifold, Bottom mounting T : Piping mounting	-	(Nil) : Scraper seal NBR (standard) V* : Scraper seal Fluorocarbon *: Fluorocarbon has been adopted for seal sections where cutting fluid is applied, as a measure for the use of chlorine-based cutting fluid (this is not thermal resistant specification).
	3					
	4					
	5					
	6					
	7					

Specifications

Model	WPB2-1	WPB2-2	WPB2-3	WPB3-1	WPB3-2	WPB3-3	WPB4-1	WPB4-2	WPB4-3
Working hydraulic pressure (MPa)	Refer to page → 213 for characteristic line diagram.								
Oil capacity (cm ³)	3.3	6.6	13.0	3.3	6.6	13.0	3.3	6.6	13.0
Pressure fluctuation per 1 cm ³ (MPa)	0.55	0.38	0.19	0.50	0.33	0.17	0.43	0.29	0.14
Mass (kg)	0.9	1.2	1.8	0.9	1.2	1.8	0.9	1.2	1.8

Model	WPB5-1	WPB5-2	WPB5-3	WPB6-1	WPB6-2	WPB6-3	WPB7-1	WPB7-2	WPB7-3
Working hydraulic pressure (MPa)	Refer to page → 213 for characteristic line diagram.								
Oil capacity (cm ³)	3.3	6.6	13.0	3.3	6.6	13.0	3.3	6.6	13.0
Pressure fluctuation per 1 cm ³ (MPa)	0.41	0.27	0.16	0.90	0.61	0.36	0.84	0.59	0.34
Mass (kg)	1.3	1.7	2.4	1.3	1.7	2.4	1.3	1.7	2.4

Proof pressure: 7 MPa (WPB2·3·4), 15 MPa (WPB5·6·7)

Operating temperature: 0 ~ 70°C

Fluid used: General mineral based working fluid (ISO-VG32 or equivalent)

Dimensions

WPB₂³₄-₁²₃ GS
 * No internal filter

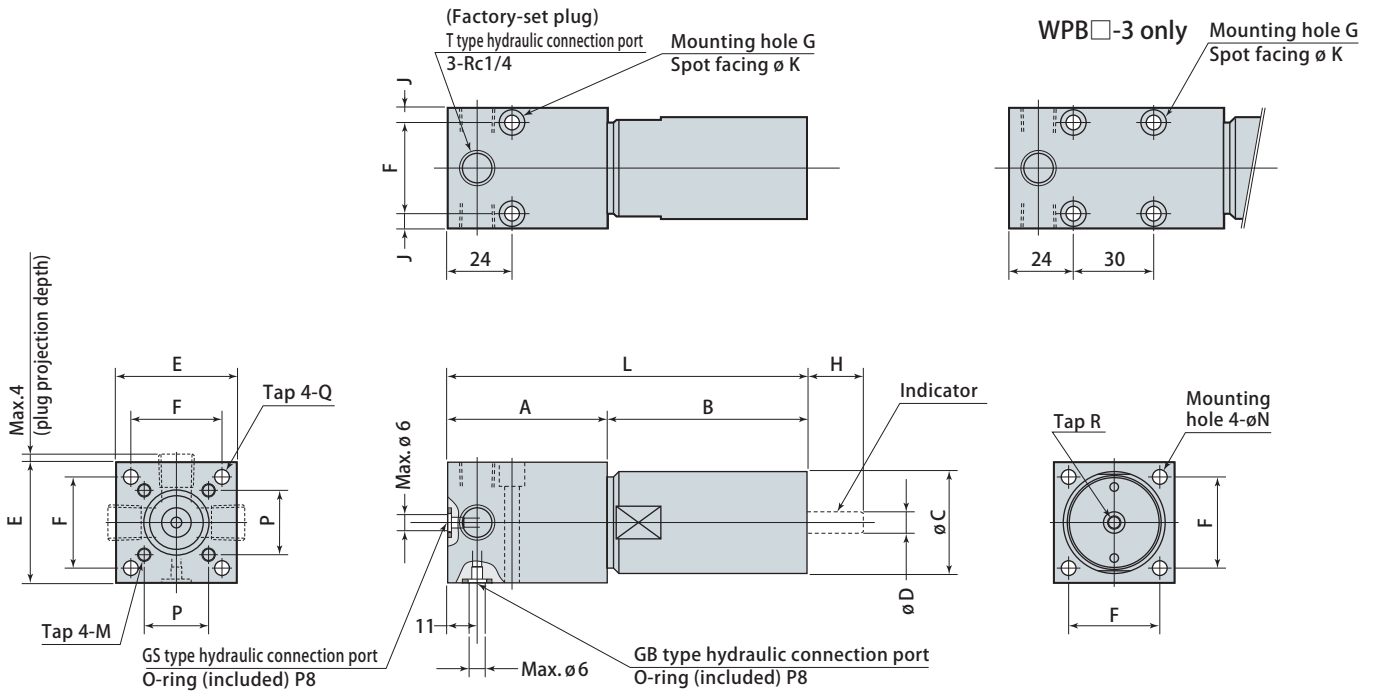

Mounting details
 Manifold, Bottom mounting (GB)

Mounting details
 Manifold, Side mounting (GS)

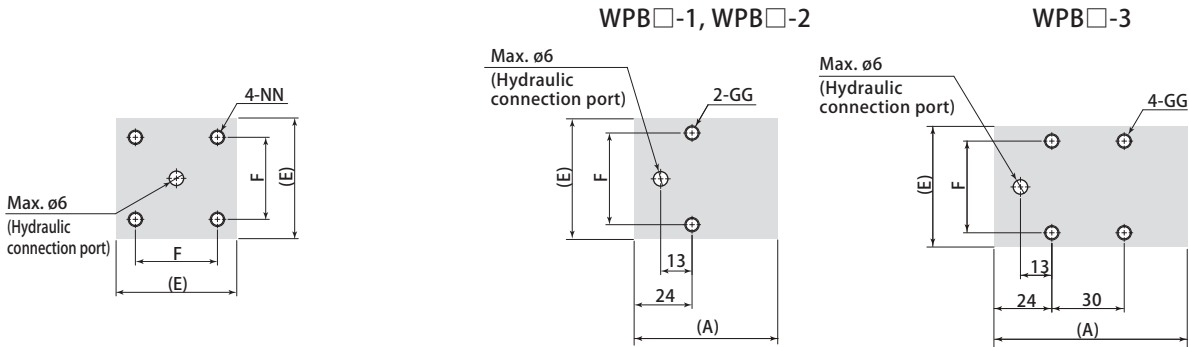

The mounting surface finish must be no rougher than Rz 6.3 (ISO4287:1997) for manifold piping.

Model		A	B	C	D	E	F	G	GG	Max. H	J	K	L	M	N	NN	P	Q	R
WPB ₂ ³ ₄	-1	49	46	38	8	45	34	2-ø5.5	M5	10.5	5.5	9.5 depth 9	95	M5×0.8 depth 10	5.5	M5	24	—	M5×0.8 depth 9
	-2	59.5	74.5					2-ø5.5		21			134						
	-3	80	151					4-ø5.5		41.5			231						
WPB ₅ ⁶ ₇	-1	49	70	42.7	10	50	38	2-ø6.8	M6	10.5	6	11 depth 11	119	—	6.8	M6	—	M8×1.25 depth 16	M6×1 depth 11
	-2	59.5	105					2-ø6.8		21			164.5						
	-3	80	186					4-ø6.8		41.5			266						

Included plug T type: 2 pieces, GS & GB type: 3 pieces. Mounting screws are not included.

Characteristic line diagram

WPB□-1

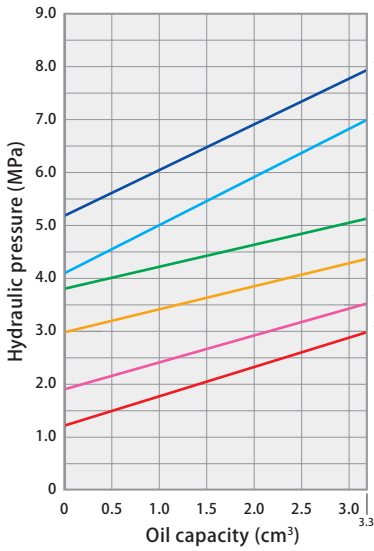

WPB□-2

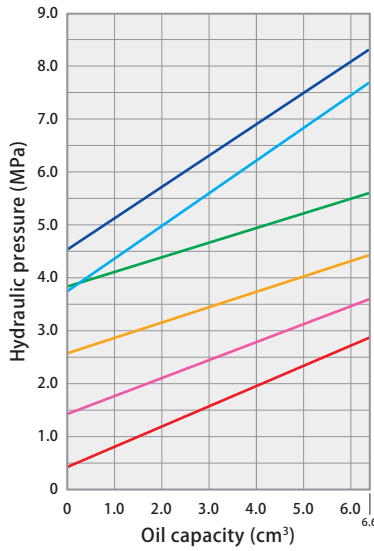

WPB□-3

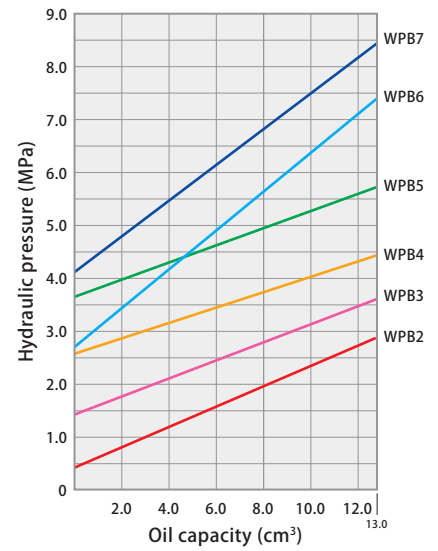

Note: This characteristic line diagram represents theoretical values.

Model selection example

Temperature condition (estimated temperature drop: 20°C)

Working clamp	CLU06×4 pieces	Piping	Inner diameter ø 6×0.6m×4 pieces
Working hydraulic pressure: P	3.5 MPa	Valve & hydraulic pressure equipment	VCB: 1 piece, VRG: 2 pieces

Selection procedure

1. Calculation of circuit capacity

Clamping capacity: $9.6 \times 2.6 \times 4 = 100 \text{ cm}^3$
Pressure bearing area Stroke Qty

Piping capacity: $0.28 \times 60 \times 4 = 67 \text{ cm}^3$

Valve & hydraulic pressure equipment capacity: $8 \times 3 = 24 \text{ cm}^3$

(Perform calculation with capacity of 8 cm³ for each of valves and hydraulic pressure equipment in hydraulic pressure circuit, when using Pascal product.)

Circuit capacity: $100 + 67 + 24 = 191 \text{ cm}^3$

2. Selection of oil capacity

Select the equipment having oil capacity capable of keeping volumetric change. Volumetric change is obtained by using formula shown below.

$\Delta V = V \times \Delta T \times \alpha$ ΔV : Volumetric change (cm³) V : Circuit capacity (cm³)
 ΔT : Temperature change (°C) α : Thermal expansion coefficient (7.8×10^{-4})

$\Delta V = 191 \times 20 \times 7.8 \times 10^{-4} = 3.0 \text{ cm}^3$

Here, WPB□-2 is selected as an example (*1).

3. Selection of WPB working pressure

Select the pressure whose oil discharge amount (*2) under working hydraulic pressure satisfies ΔV calculated in step 2. Read off characteristic line diagram.

If the working hydraulic pressure is 3.5 MPa, select WPB3-2 or WPB4-2.

4. Verification of hydraulic pressure and residual discharge amount (*2) after temperature change

Select the one whose hydraulic pressure drop after temperature change is low and residual discharge amount (*2) satisfies the marginal oil amount (*3). Read off characteristic line diagram. Hydraulic pressure drops to 2.5 MPa with WPB3-2 (P3) and to 2.6 MPa with WPB4-2 (P4) after temperature change. Residual discharge amount (*2) becomes 3.3 cm³ with WPB3-2 (V3) and 0.3 cm³ with WPB4-2 (V4). In this case, select WPB3-2□ with the marginal amount retained.

5. Select piping method.

- *1: WPB□-1 and WPB□-3 are also selectable. Likewise, select appropriate one in consideration of steps 3 and 4.
- *2: When the temperature decreases. If the temperature increases, check the absorption amount.
- *3: Allow adequate margin for residual discharge amount after temperature change, as there may be margin of error with spring force of internal spring. Marginal oil amount: WPB□-1: About 0.5 cm³, WPB□-2: About 1.0 cm³, WPB□-3: About 1.5 cm³

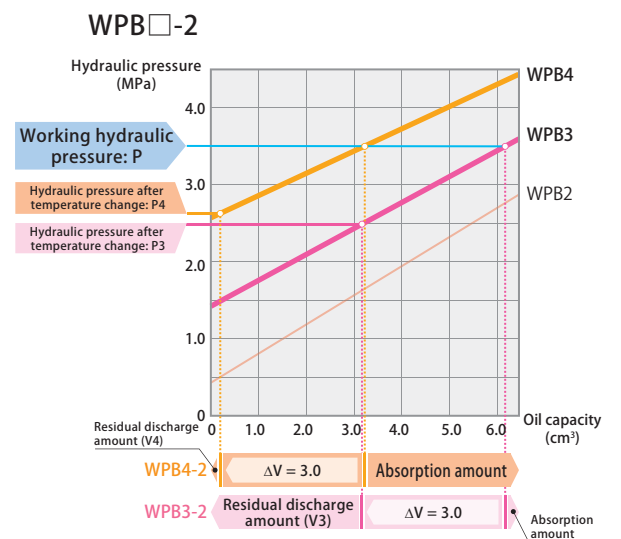
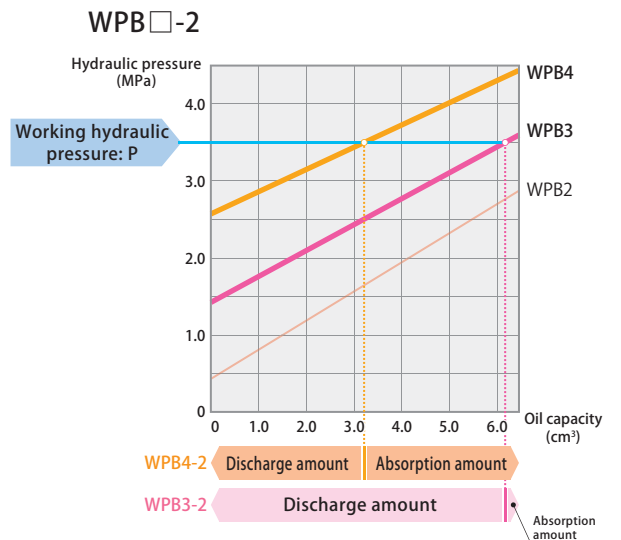



Accumulator model **WPC**

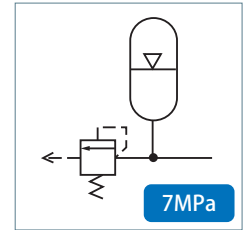
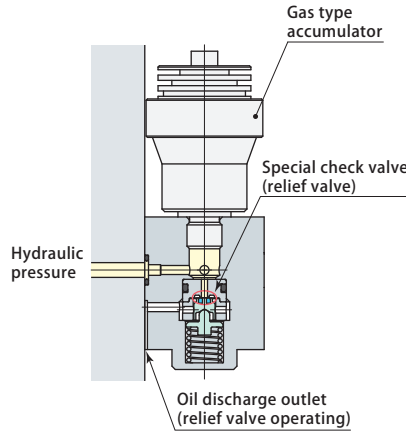

N₂ pressure type accumulator. Equipped with a relief valve for preventing breakdown of device in case of problems with circuit pressure (high pressure).

Specifications

Model	WPC13L-T <small>Gas pressure *</small>	WPC13L-G <small>Gas pressure *</small>	WPC40L-T <small>Gas pressure *</small>	WPC40L-G <small>Gas pressure *</small>
Mounting/piping methods	Piping mounting	Manifold	Piping mounting	Manifold
Working pressure range (MPa)	Refer to page → 216 for characteristic line diagram.			
Gas capacity (cm ³)		13		40
Oil discharge/absorption amount (cm ³)		10		30
Mass (kg)		1.1		1.6

Proof pressure : 10.5 MPa Operating temperature: 0 ~ 60°C Fluid used: General mineral based hydraulic oil (ISO-VG32 equivalent)

* Initially filled gas pressure can be set in range of 1 MPa to 6 MPa with 0.5 MPa increment. Specify gas pressure when ordering. Example : WPC13L-T3.0 (gas pressure 3 MPa)
There is also a type that adopts fluorocarbon for seal sections where cutting fluid is applied, as a measure for the use of chlorine-based cutting fluid (this is not thermal resistant specification. Model designation WPC□L-□□-V).

Dimensions

WPC13L-G□ * No internal filter

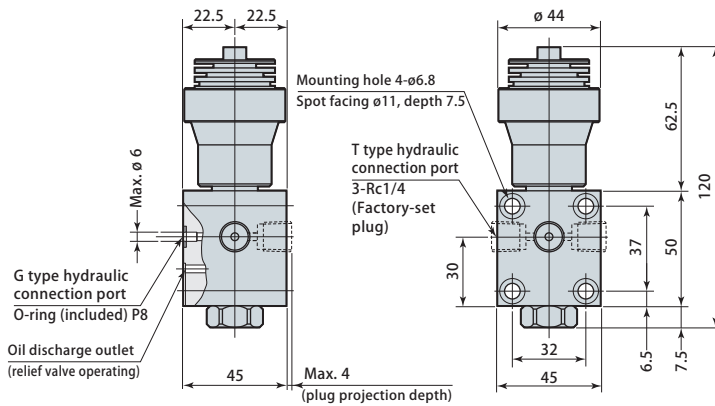

Mounting details

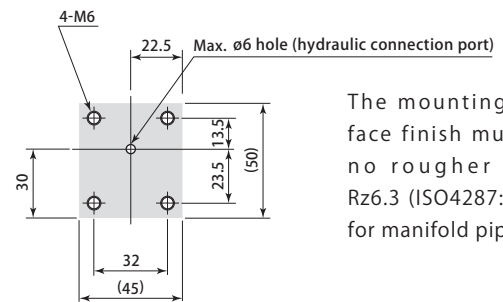

The mounting surface finish must be no rougher than Rz6.3 (ISO4287:1997) for manifold piping.

WPC40L-G□ * No internal filter

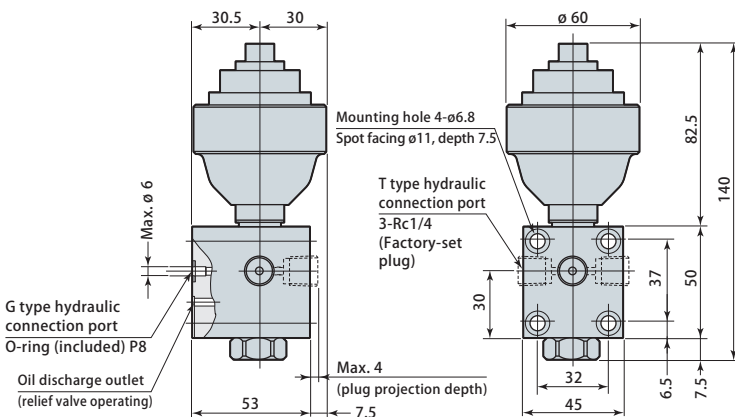

Mounting details

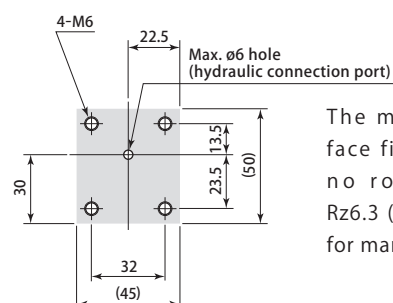

The mounting surface finish must be no rougher than Rz6.3 (ISO4287:1997) for manifold piping.

Mounting screws are not included.

Characteristic line diagram

WPC13L

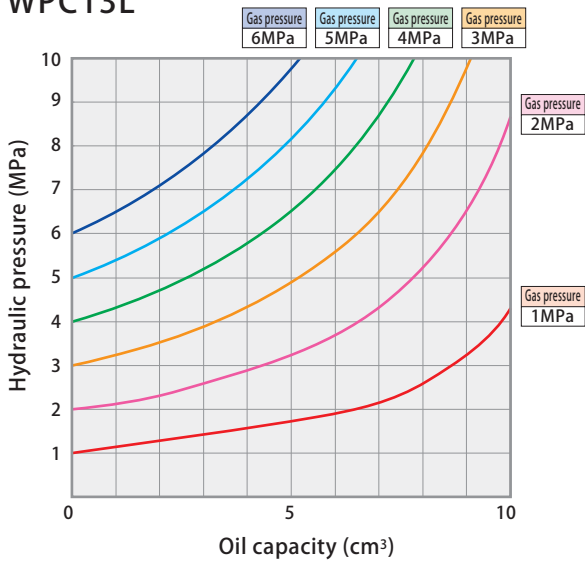

WPC40L

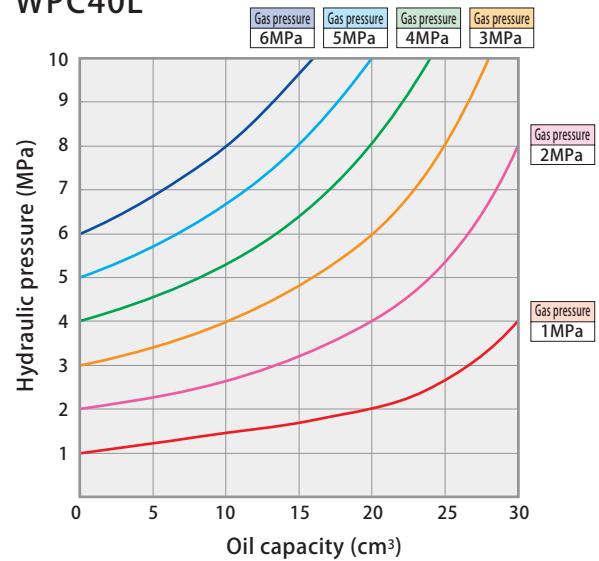

Note: This characteristic line diagram represents theoretical values.

Model selection example

Condition (estimated temperature drop: 20°C)

Working clamp	CTU06×8 pieces	Piping	Inner diameter ø6×0.8 m×8 pieces
Working hydraulic pressure: P	6 MPa	Valve & hydraulic pressure equipment	VCB: 1 piece, VRG: 2 pieces

Selection procedure

1. Calculation of circuit capacity

Clamping capacity: $8.9 \times 2.35 \times 8 = 167 \text{ cm}^3$
Pressure bearing area Stroke Qty

Piping capacity: $0.28 \times 80 \times 8 = 179 \text{ cm}^3$

Valve & hydraulic pressure equipment capacity: $8 \times 3 = 24 \text{ cm}^3$

(Perform calculation with capacity of 8 cm³ for each of valves and hydraulic pressure equipment in hydraulic pressure circuit, when using Pascal product.)

Circuit capacity: $167 + 179 + 24 = 370 \text{ cm}^3$

2. Selection of oil capacity

Select the equipment having oil capacity capable of keeping volumetric change.

Volumetric change is obtained by using formula shown below.

$$\Delta V = V \times \Delta T \times \alpha$$

ΔV : Volumetric change (cm³) V : Circuit capacity (cm³)
 ΔT : Temperature change (°C) α : Thermal expansion coefficient (7.8×10^{-4})

$$\Delta V = 370 \times 20 \times 7.8 \times 10^{-4} = 5.8 \text{ cm}^3$$

Here, WPC40L is selected as an example (*1).

3. Selection of gas pressure

Select the pressure whose oil discharge amount (*2) under working hydraulic pressure satisfies ΔV calculated in step 2.

Read off characteristic line diagram.

If the working hydraulic pressure of the clamping circuit is 6 MPa, select the gas pressure 2 MPa, 3 MPa, or 4 MPa.

4. Verification of hydraulic pressure and residual discharge amount (*2) after temperature change

Select the one whose hydraulic pressure drop after temperature change is low and residual discharge amount (*2) satisfies the marginal oil amount (*3). Read off characteristic line diagram.

The hydraulic pressure after temperature change drops to 4.2 MPa with 2 MPa gas pressure (P2), to 4.7 MPa with 3 MPa gas pressure (P3), and to 4.9 MPa with 4 MPa gas pressure (P4), respectively.

The residual discharge amount (*2) is 20.9 cm³ for 2 MPa gas pressure (V2), 14.2 cm³ for 3 MPa (V3), and 7.5 cm³ for 4 MPa (V4), respectively.

Here, select WPC40L-□4 whose pressure drop is low.

5. Select piping method.

*1: WPC13L is also available. Likewise, select appropriate one in consideration of steps 3 and 4.

*2: For when the temperature decreases. If the temperature increases, check the absorption amount.

*3: Allow adequate margin for residual discharge amount after temperature change, as there may be margin of error with gas filling pressure. Marginal oil amount: About 2.0 cm³

WPC40L

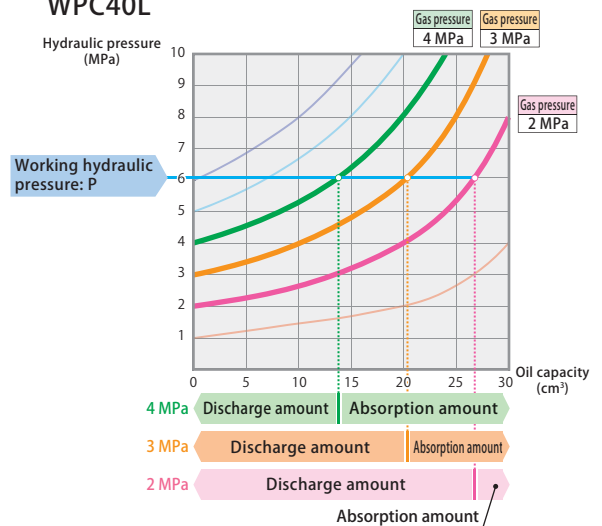

WPC40L

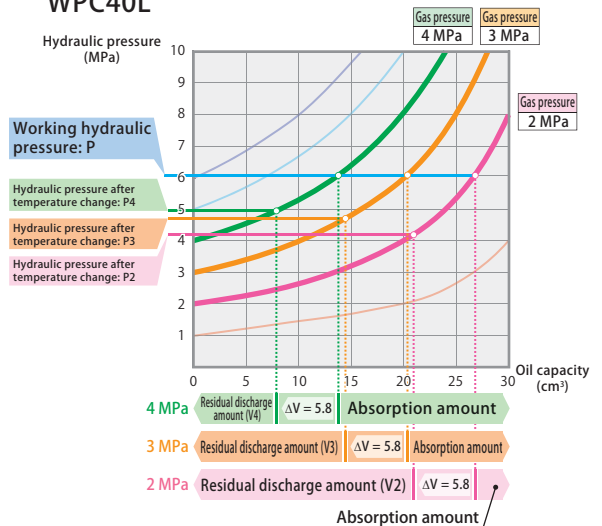

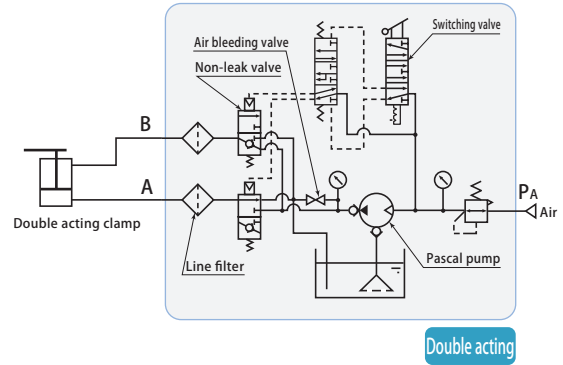

Control unit model **HCD₅-W**

This is a hydraulic control unit that is air driven and manually operated, combining non-leak valve with non-leak feature (zero oil leaks), which is essential for hydraulic clamps, and Pascal pump. Since two hydraulic circuits can be operated and controlled alternately, it is the best suited hydraulic pressure source for double acting clamps.

Pascal pump stops pumping once circuit pressure has been attained and retains the pressure. Furthermore, since there is hardly any temperature fluctuation of working fluid, there is no need for any auxiliary pressure equipment (mount accumulator WPB or WPC in clamping circuit when storing for long time after disconnecting hydraulic pressure source or where ambient temperature change is significant).

Model	HCD4-W	HCD5-W
Pascal pump models	HPX6312P-D	HPX6316P-D
Discharge oil pressure *1 (MPa)	3.6 ~ 10.8	2.25 ~ 6.75
Set air pressure (MPa)	0.2 ~ 0.5	
Unloaded oil discharge amount (ℓ/min)	Refer to page → 220 for pump performance diagram.	
Tank capacity (ℓ)	3	
Operating temperature (°C)	5 ~ 60	
Fluid used	General mineral based hydraulic oil (ISO-VG32 equivalent)	
Mass (kg)	24	

*1 : Ask for consultation on specifications that exceed discharge oil pressure range.

Dimensions

HCD₅-W Double acting circuit control unit

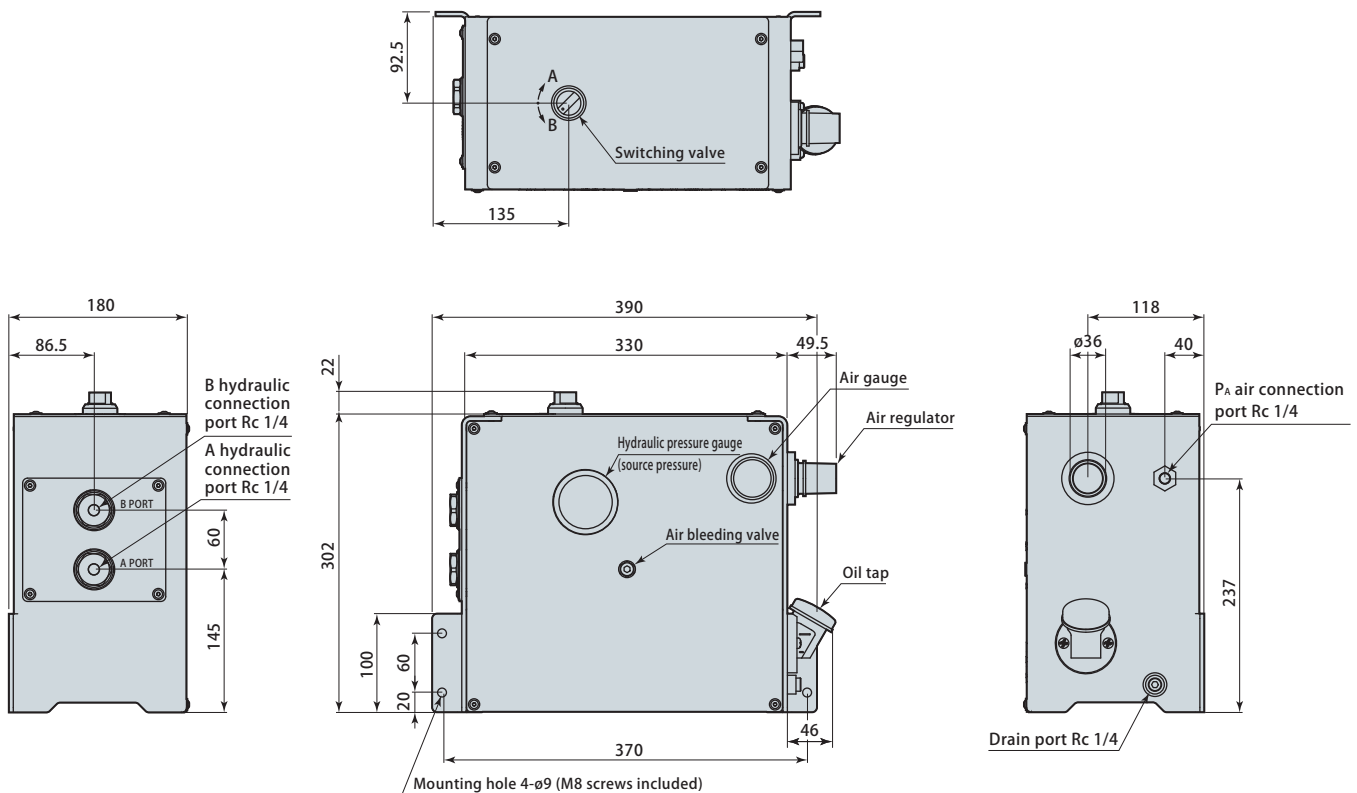

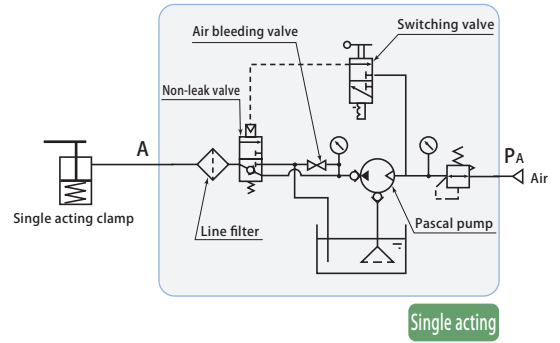

Control unit model **HCD⁴₅-S**

This is a hydraulic control unit that is air driven and manually operated, combining non-leak valve with non-leak feature (zero oil leaks), which is essential for hydraulic clamps, and Pascal pump. Pascal pump stops pumping once circuit pressure has been attained and retains the pressure. Furthermore, since there is hardly any temperature fluctuation of working fluid, there is no need for any auxiliary pressure equipment (mount accumulator WPB or WPC in clamping circuit when storing for long time after disconnecting hydraulic pressure source or where ambient temperature change is significant).

Model	HCD4-S	HCD5-S
Pascal pump models	HPX6312P-D	HPX6316P-D
Discharge oil pressure *1 (MPa)	3.6 ~ 10.8	2.25 ~ 6.75
Set air pressure (MPa)	0.2 ~ 0.5	
Unloaded oil discharge amount (ℓ/min)	Refer to page → 220 for pump performance diagram.	
Tank capacity (ℓ)	3	
Operating temperature (°C)	5 ~ 60	
Fluid used	General mineral based hydraulic oil (ISO-VG32 equivalent)	
Mass (kg)	22	

*1 : Ask for consultation on specifications that exceed discharge oil pressure range.

Dimensions

HCD⁴₅-S Single acting circuit control unit

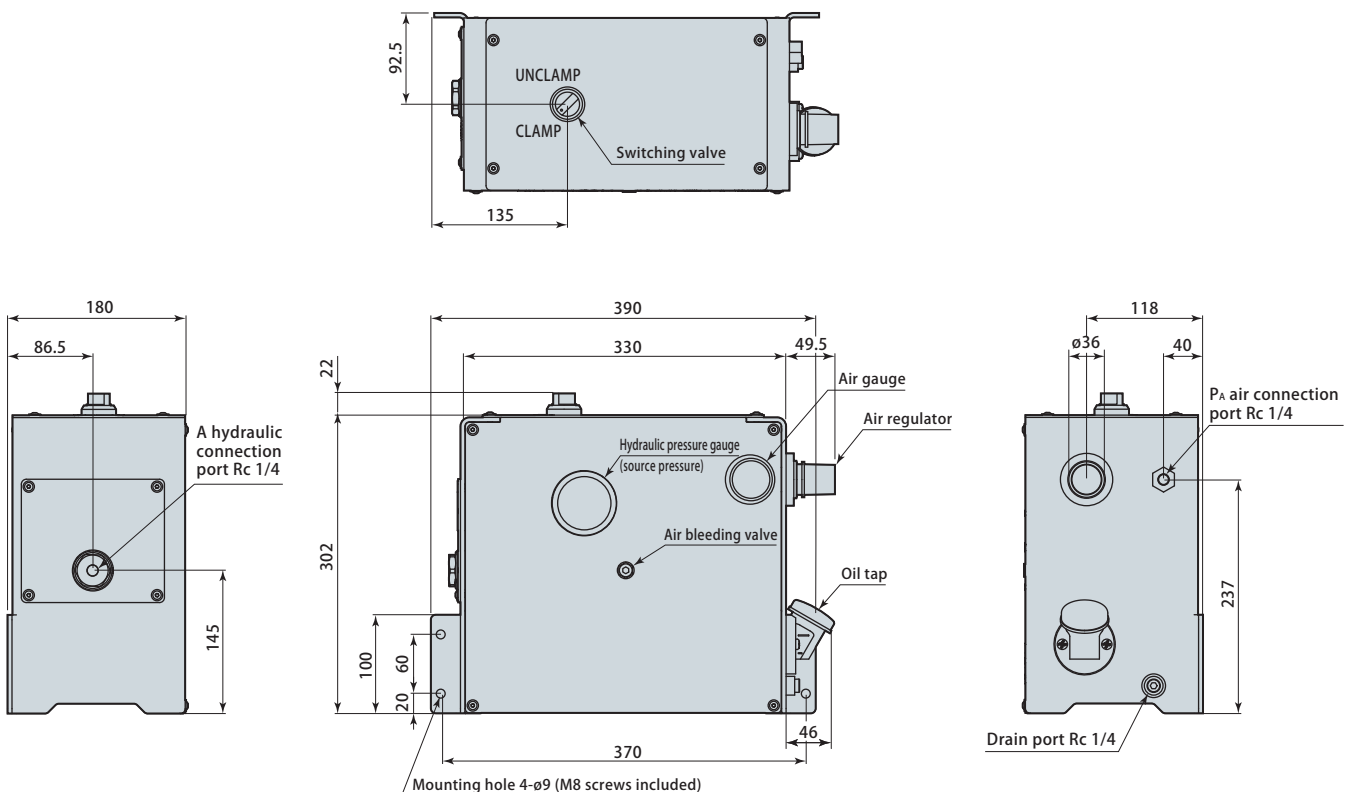



Control unit model **HCT**

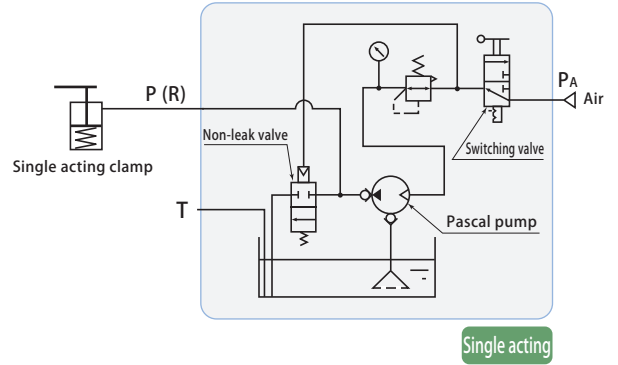

Single acting

Compact hydraulic control unit for air drive and manual operations. Pascal pump stops pumping once circuit pressure has been attained and retains the pressure. Furthermore, since there is hardly any temperature fluctuation of working fluid, there is no need for any auxiliary pressure equipment (mount accumulator WPB or WPC in clamping circuit when storing for long time after disconnecting hydraulic pressure source or where ambient temperature change is significant).

Model	HCT-4	HCT-5
Pascal pump models	HPX6312-HCK-C	HPX6316-HCK-C
Discharge oil pressure *1 (MPa)	3.6 ~ 10.8	2.25 ~ 6.75
Set air pressure (MPa)	0.2 ~ 0.5	
Unloaded oil discharge amount (ℓ/min)	Refer to page → 220 for performance diagram.	
Tank capacity (ℓ)	1.5	
Operating temperature (°C)	5 ~ 60	
Fluid used	General mineral based hydraulic oil (ISO-VG32 equivalent)	
Mass (kg)	8.3	

*1 : Ask for consultation on specifications that exceed discharge oil pressure range.

Dimensions

HCT-⁴/₅ Single acting circuit hydraulic control unit

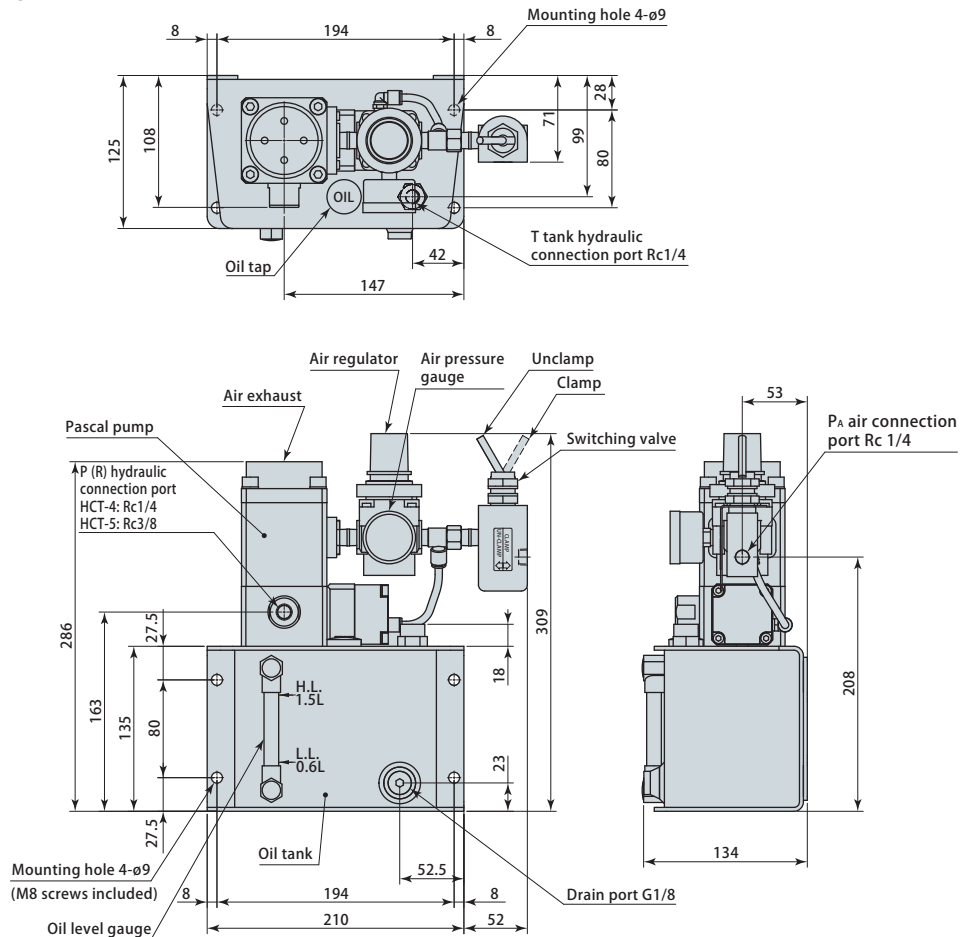

Control system



Pascal pump model **HPX**

- Air-driven, compact, high performance hydraulic pump.
- Pascal pump is a compact but reliable hydraulic pump, which converts a compressed air force into high-pressure hydraulic power.
- Secure and high speed reciprocation of air and hydraulic piston generates a repetitive suction and discharge of air and oil. As the hydraulic pressure becomes close to the designated level, the reciprocation becomes slower. At the designated hydraulic pressure, the driving air force and hydraulic force become balanced to maintain the pressure.
- At the balanced condition, there is no air consumption so that there is no power loss or temperature rise compared to an electric pump. In the event of an air supply failure, the hydraulic pressure can be kept by the built-in check valve on the discharge side.
- If there is a decrease in the downstream holding pressure, the pump immediately reacts to start reciprocating to recover the pressure loss.

Model	HPX6312	HPX6316	Air pressure range	0.2 ~ 0.7 MPa
Boosting ratio	24	15	Air consumption	0.5 Nm ³ /min
Mass	2.6 kg		Operating noise	78±1 db (A)
			Operating temperature	0 ~ 70 °C (No frozen)

Performance diagram [Measured with operating oil ISO VG32 at 20°C]

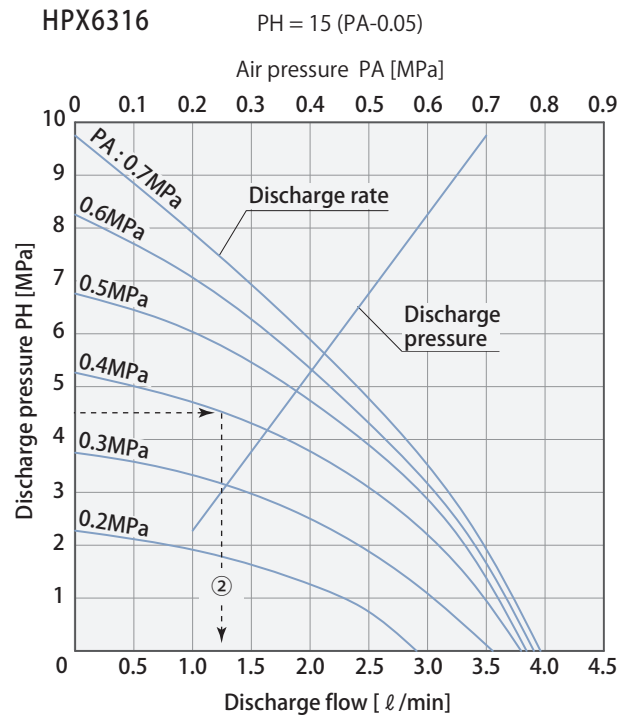
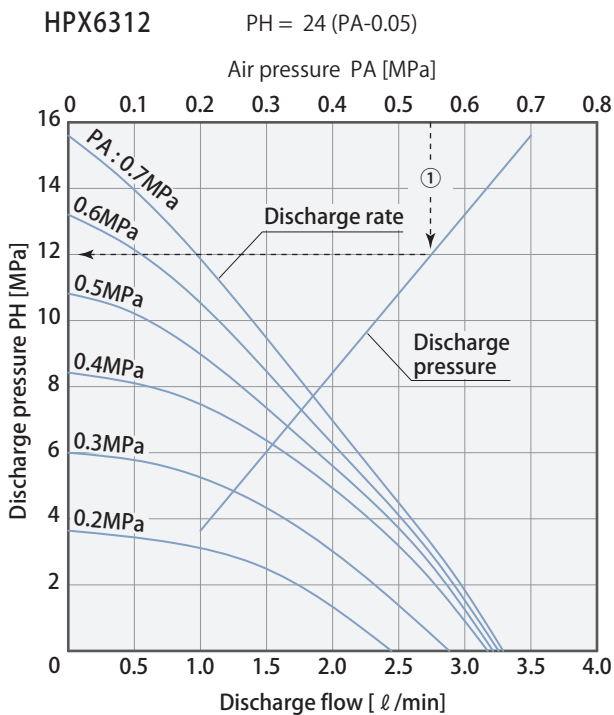

How to read the graph

1. To find discharge pressure PH [ex : HPX6312]
 At air pressure PA=0.55MPa, see above broken line ① showing PH=12MPa
 Calculation : PH=24 x (0.55 - 0.05)=12MPa

2. To find discharge flow [ex:HPX6316]
 At air pressure PA=0.4MPa and discharge pressure PH = 4.5MPa, see above broken line ② showing 1.25 l /min