

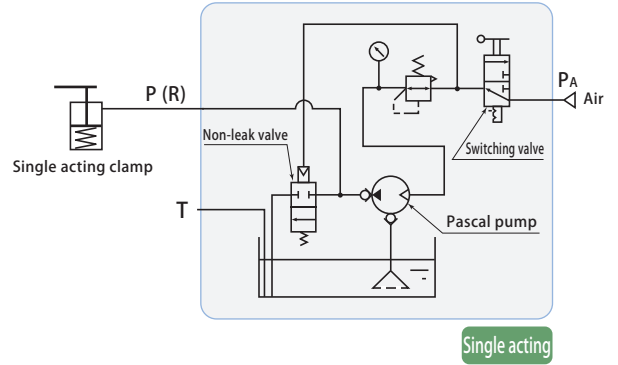

Control unit model **HCT**



Single acting

Compact hydraulic control unit for air drive and manual operations. Pascal pump stops pumping once circuit pressure has been attained and retains the pressure. Furthermore, since there is hardly any temperature fluctuation of working fluid, there is no need for any auxiliary pressure equipment (mount accumulator WPB or WPC in clamping circuit when storing for long time after disconnecting hydraulic pressure source or where ambient temperature change is significant).

Model	HCT-4	HCT-5
Pascal pump models	HPX6312-HCK-C	HPX6316-HCK-C
Discharge oil pressure *1 (MPa)	3.6 ~ 10.8	2.25 ~ 6.75
Set air pressure (MPa)	0.2 ~ 0.5	
Unloaded oil discharge amount (ℓ/min)	Refer to page → 220 for performance diagram.	
Tank capacity (ℓ)	1.5	
Operating temperature (°C)	5 ~ 60	
Fluid used	General mineral based hydraulic oil (ISO-VG32 equivalent)	
Mass (kg)	8.3	

*1 : Ask for consultation on specifications that exceed discharge oil pressure range.

Dimensions

HCT-4/5 Single acting circuit hydraulic control unit

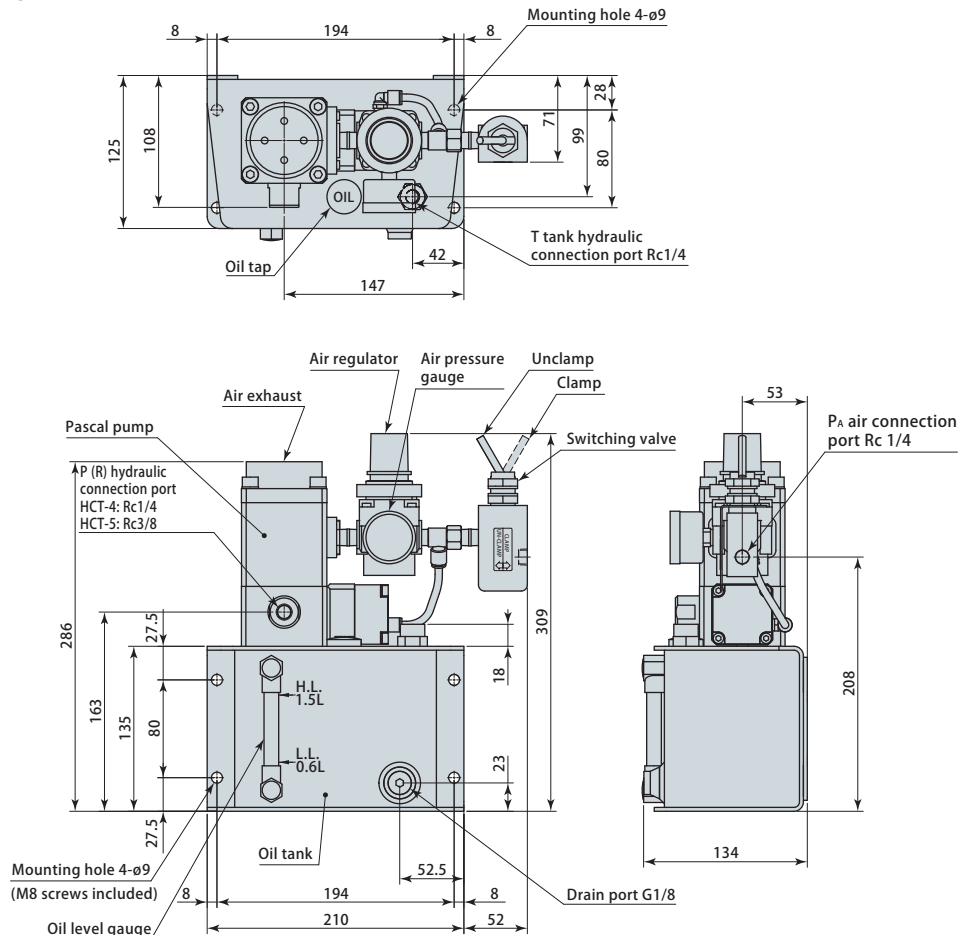

Control system



Pascal pump model **HPX**

- Air-driven, compact, high performance hydraulic pump.
- Pascal pump is a compact but reliable hydraulic pump, which converts a compressed air force into high-pressure hydraulic power.
- Secure and high speed reciprocation of air and hydraulic piston generates a repetitive suction and discharge of air and oil. As the hydraulic pressure becomes close to the designated level, the reciprocation becomes slower. At the designated hydraulic pressure, the driving air force and hydraulic force become balanced to maintain the pressure.
- At the balanced condition, there is no air consumption so that there is no power loss or temperature rise compared to an electric pump. In the event of an air supply failure, the hydraulic pressure can be kept by the built-in check valve on the discharge side.
- If there is a decrease in the downstream holding pressure, the pump immediately reacts to start reciprocating to recover the pressure loss.

Model	HPX6312	HPX6316	Air pressure range	0.2 ~ 0.7 MPa
Boosting ratio	24	15	Air consumption	0.5 Nm ³ /min
Mass	2.6 kg		Operating noise	78±1 db (A)
			Operating temperature	0 ~ 70 °C (No frozen)

Performance diagram [Measured with operating oil ISO VG32 at 20°C]

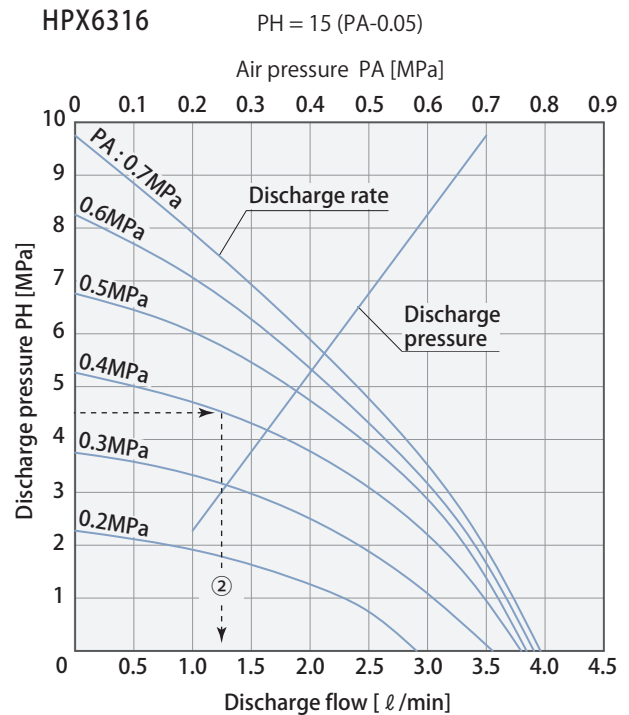
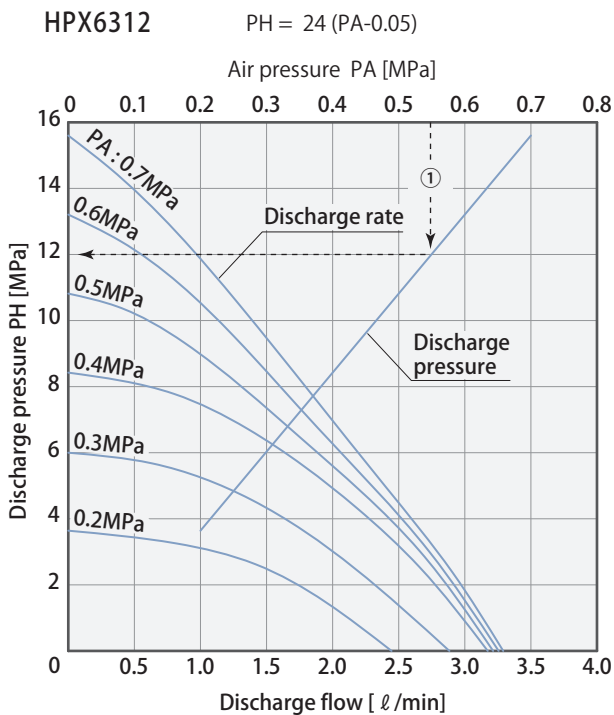

How to read the graph

1. To find discharge pressure PH [ex : HPX6312]
 At air pressure PA=0.55MPa, see above broken line ① showing PH=12MPa
 Calculation : PH=24 x (0.55 - 0.05)=12MPa

2. To find discharge flow [ex:HPX6316]
 At air pressure PA=0.4MPa and discharge pressure PH = 4.5MPa, see above broken line ② showing 1.25 l /min