

Double acting clamp is controlled and operated with control unit model HCD□-W and coupling valve model VCB.



Control unit model **HCD₃-W**
page → 457



Coupling valve model **VCB**
pages → 447 and 448

Control unit (HCD2-W) converts air pressure (about 0.5 MPa) to hydraulic pressure (25 MPa) by actuation of air driven Pascal pump. Once circuit pressure is attained to the set pressure, it stops pumping then keeps the hydraulic pressure.

Coupling valve (VCB) is placed between a control unit and double acting clamps, and it allows to disconnect the control unit from the valve by means of hydraulic coupler. Built-in check valve in coupling valve can positively seal the pressure.

Clamping operation

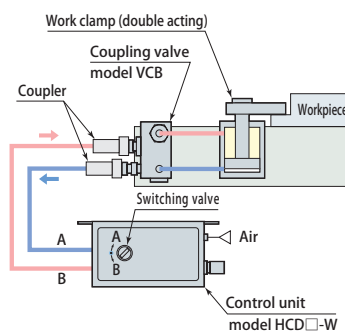

After coupler is connected, workpiece is clamped by aligning switching valve of control unit to B hydraulic connection port (clamping circuit).

Hydraulic pressure source disengagement (during processing)

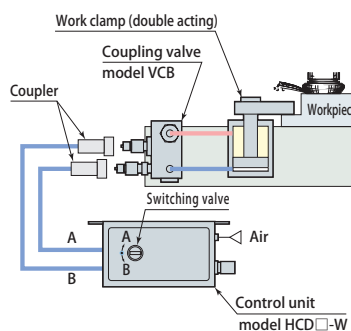

Coupler is released by aligning switching valve of control unit to center position after workpiece clamping is completed.

Unclamping operation

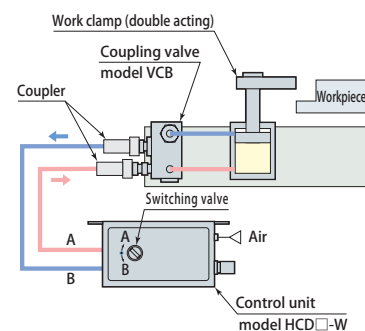

After coupler is connected, workpiece is taken out by unclamping, which is made possible by aligning switching valve of control unit to A hydraulic connection port (unclamping circuit).

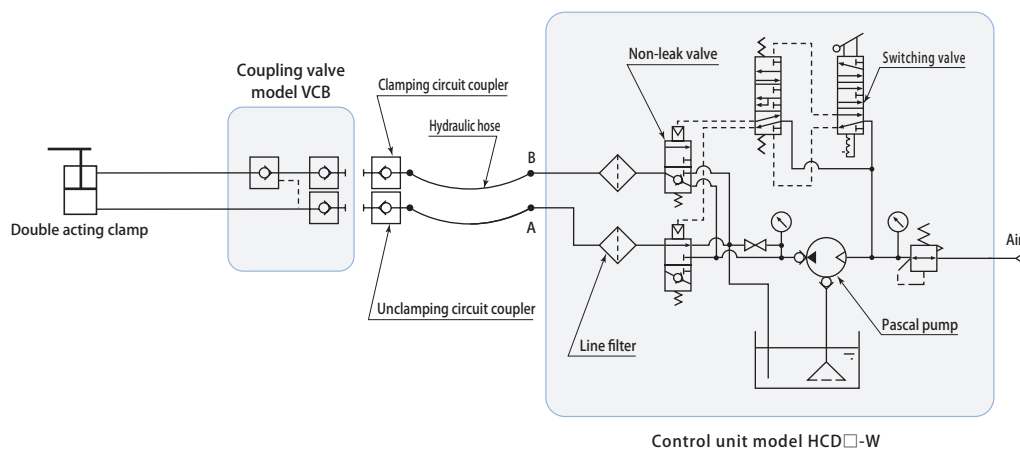

* Since Pascal pump does not raise oil temperature like electrical pumps, it does not trigger pressure drop (reduction in clamping force) after clamping due to difference between ambient temperature and oil temperature. Fluctuation of pressure due to changes in ambient temperature, however, does occur. (This fluctuation presents minimal problems with ordinary cutting processes. Inquire for details.)



Internal hydraulic pressure of circuit can be partially reduced.
(Example) For work support 25 MPa (primary pressure)
pressure of work clamp is reduced to 10 MPa.

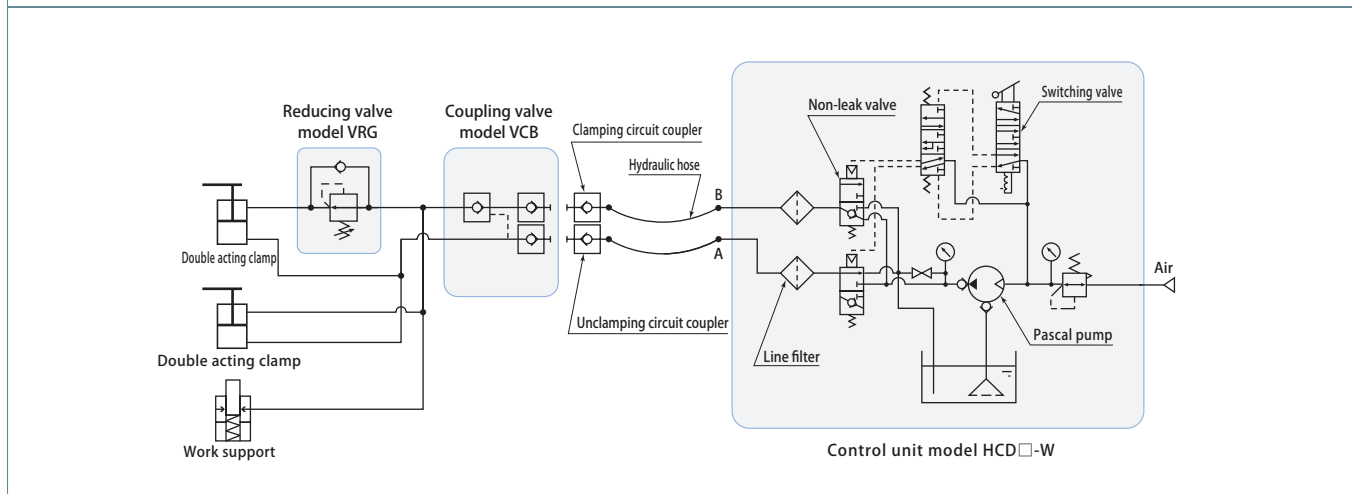
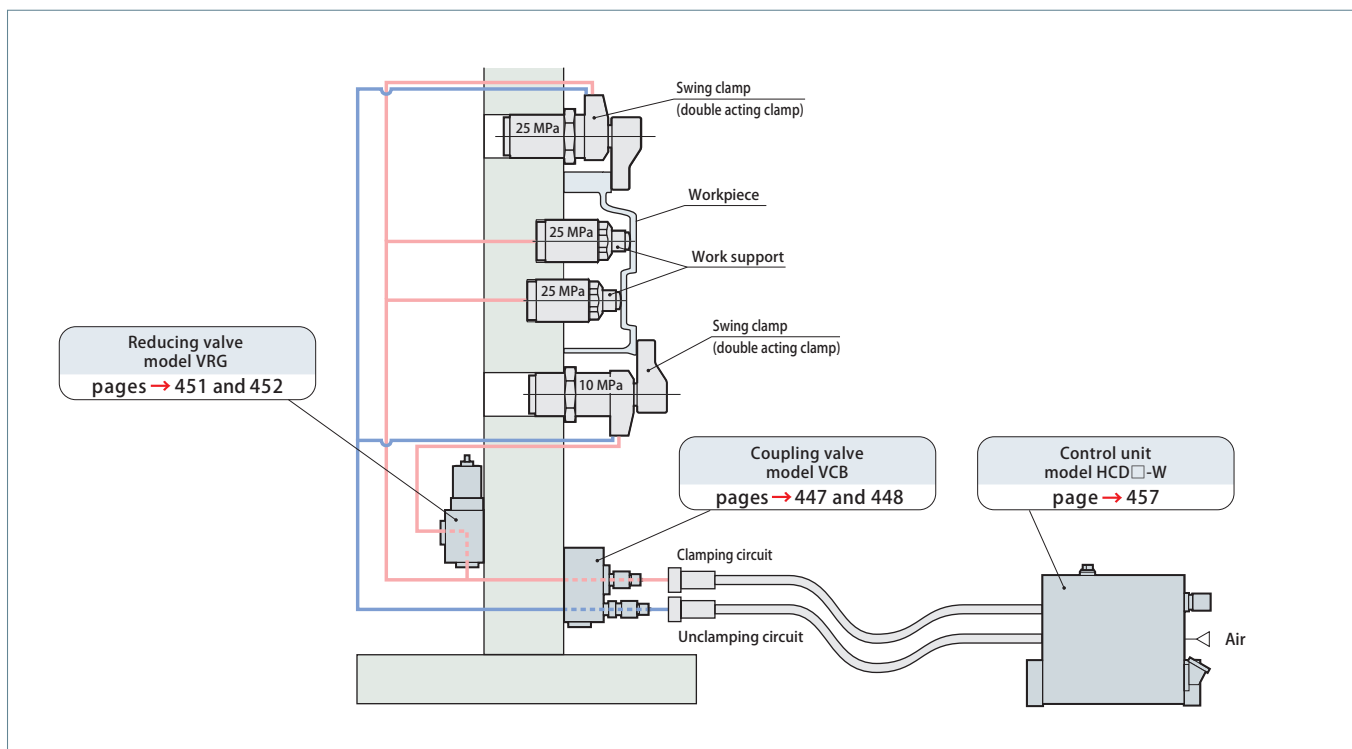



Sequence valve model **VED**
pages → 453 and 454

Work clamp and work support are sequentially operated through same circuit.

(Example) ① After operating work support lock

② Work clamp operation performed.

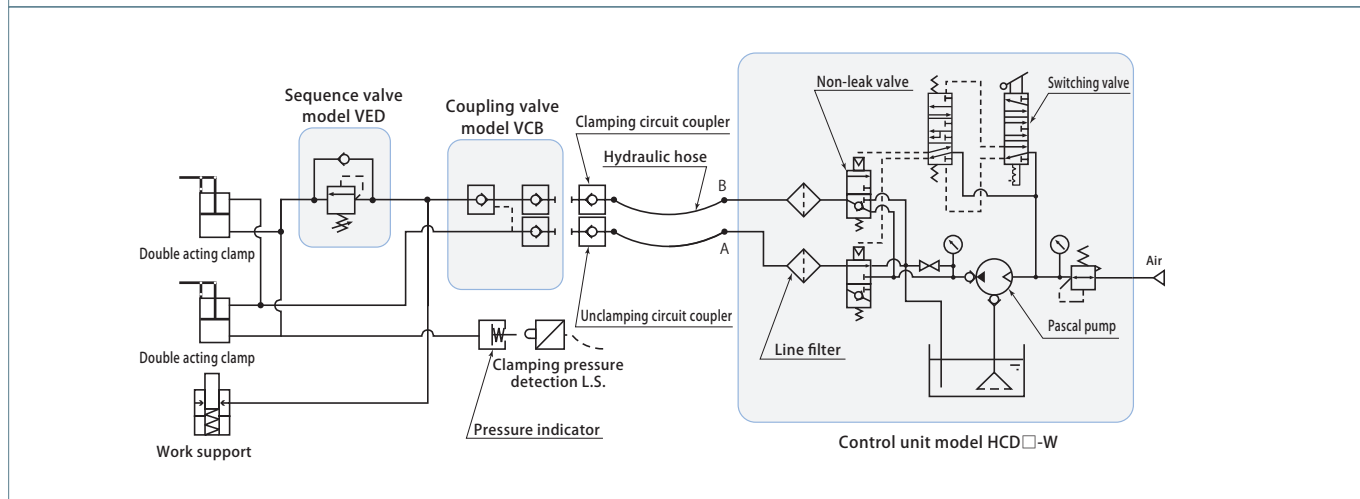
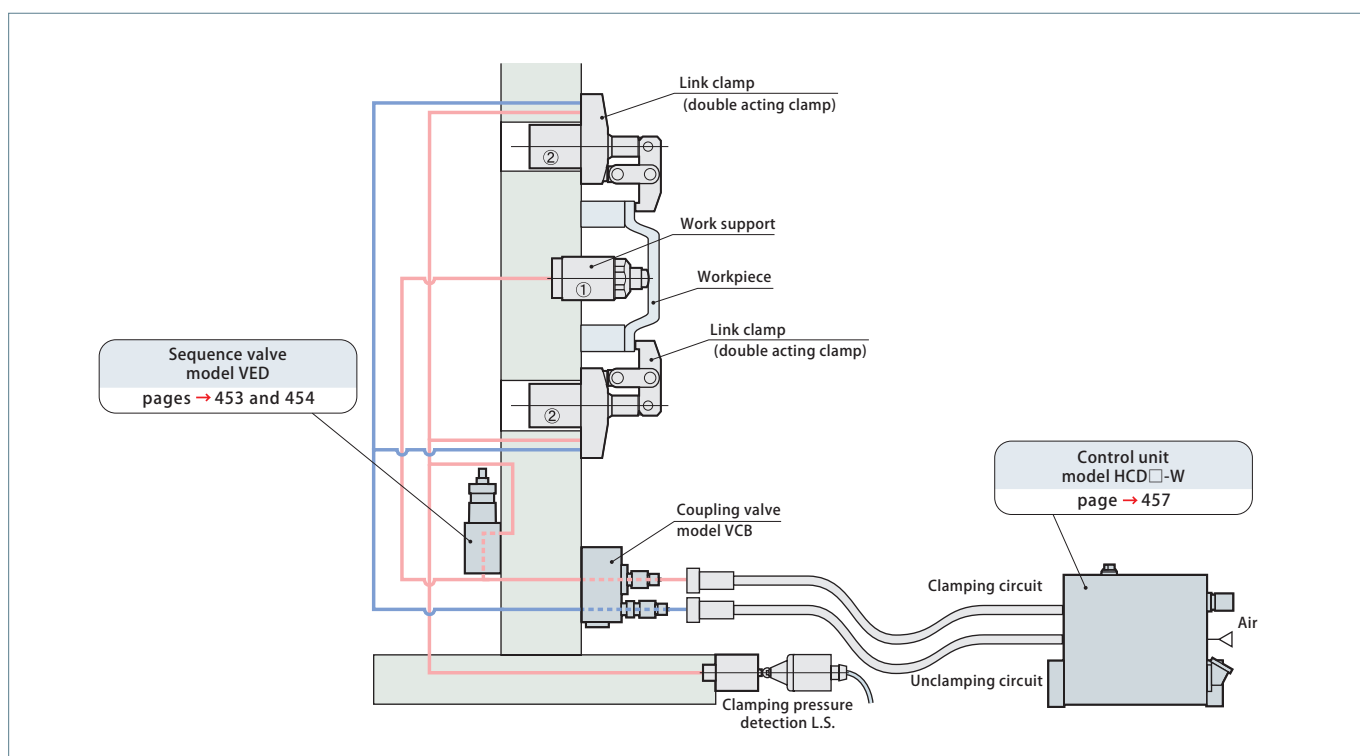



Accumulator model **WPC**
pages → 455 and 456

After hydraulic pressure source has been disengaged, circuit pressure fluctuation due to temperature changes is suppressed.

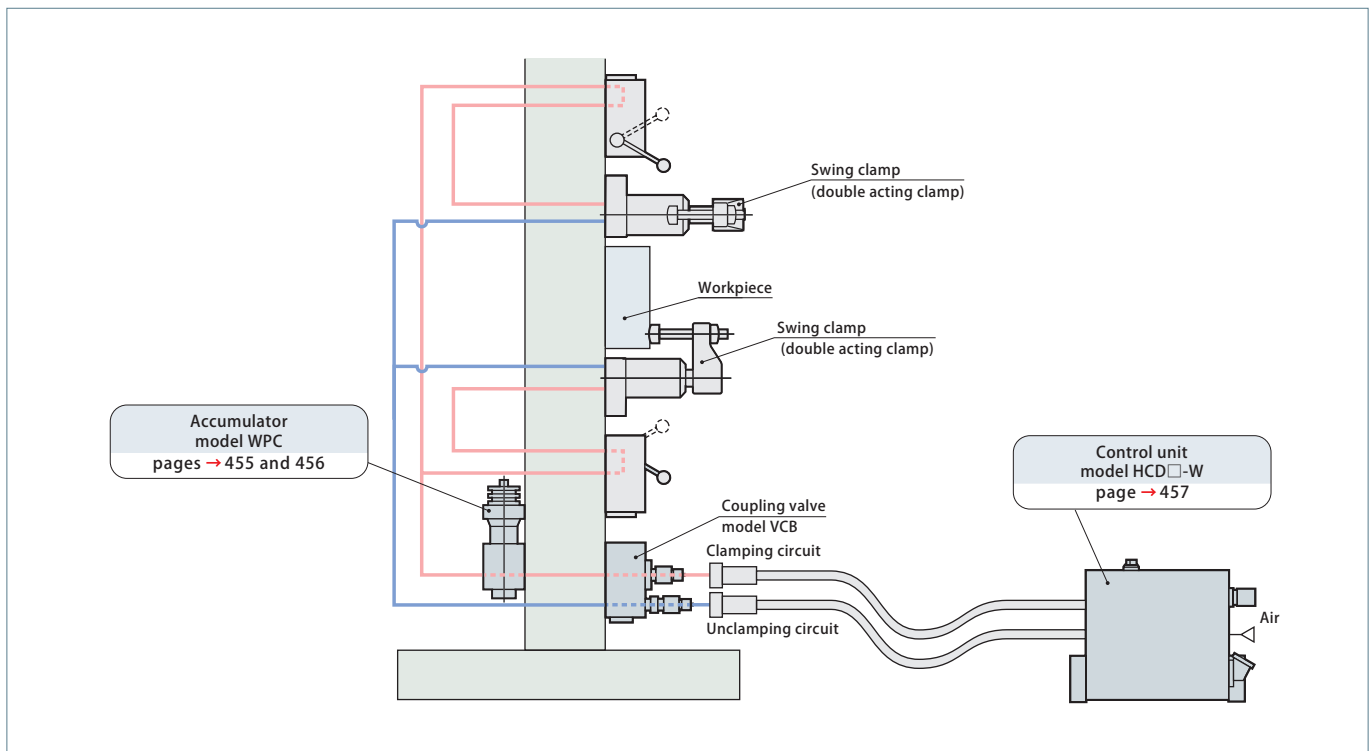

⚠ Cautions

When using double acting swing clamps, be sure to perform unclamping operation on all clamps at the same time.

Exerting hydraulic pressure to unclamping side while keeping clamping circuit of some clamps closed with two-way valve results in exertion of abnormal pressure on clamping side, which causes malfunction.

Clamping operation can be performed for each individual clamp.

