

Specifications

Model	VCE01	VCE02	VCE03
Recommended tightening torque (N·m)	10	30	35
Working pressure range (MPa)	1 ~ 50		
Operating temperature (°C)	0 ~ 70		
Fluid used	General mineral based hydraulic oil (ISO-VG32 equivalent)		

Model designation

VCE ①

(Example: VCE02)

① BSPP size

VCE

01 : G1/8

02 : G1/4

03 : G3/8



Dimensions

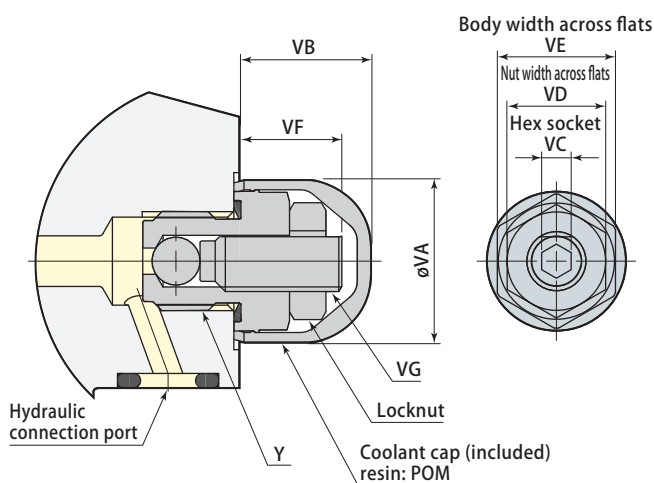

Mounting details

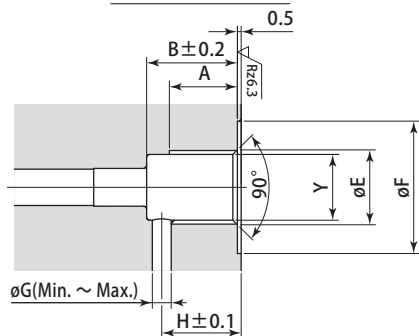

Rz: ISO4287(1997)

(mm)

Model	VCE01	VCE02	VCE03
A	9	13	13
B	13	18	19
E	9.9	13.3	16.8
F	17.5	21.5	24.5
G	2.5 ~ 3	3.5 ~ 5	5 ~ 6
H	10	15	15.5
Y	G1/8	G1/4	G3/8
VA	16	21	24
VB	13	13	14
VC	3	3	3
VD	10	10	10
VE	12	17	19
VF	10.5	10.5	11.5
VG	M6×1	M6×1	M6×1

Note 1. Use a closed wrench or socket wrench for mounting and dismounting.

2. Air bleeding valve can be mounted on hydraulic connection port (BSPP part) when manifold piping.

Mounting correspondence table

Model	VCE01	VCE02	VCE03
Swing clamp (double acting)	CTU01-02-04-06 BTU02-04-06	CTU10-16 BTU10-16	CTU25 BTU25
Swing clamp (single acting)	CTT01-02-04-06	CTT10-16	CTT25
Link clamp (double acting)	CLU02-04-06 BLU02-04-06	CLU10-16 BLU10-16	CLU25 BLU25
Link clamp (single acting)	CLT02-04-06	CLT10-16	CLT25
Push/pull cylinder	CNA02-04-06	CNA10-16	CNA25
Work support	CSU CST CSP-D(CSY-CSN-CSK)	—	—