

- Do not use a mold with the plate that is deformed or warped. Clamp force decreases due to the gap between the mold plate and clamp plate.
- Be sure to use mag clamp by keeping the contact surfaces of mold plate and clamp plate always clean. Water or oil on the mag clamp may not cause a decrease of clamp force however dusts or foreign substances being attracted by a magnet may create a gap between the mold plate and clamp plate.
- In case that there are some dents on the contact surfaces of mold plate and clamp plate, remove the convex part using the oilstone.

Check the below to improve the safety

- Mag clamp generates a powerful magnetism. The person who is wearing a cardiac pacemaker is strictly prohibited to approach. Projecting height of magnetic flux above the clamp plate towards forward (to mold side) is just around 20 mm. However, be sure not to bring mobile phone, magnetic card or compact disc, etc. that are susceptible to magnetism close to the clamp plate to avoid a damage.
- Do not bring any magnetic substance such as ferrous metal close to the adherence surface when mag clamp is at clamping (magnetized). Due to the power of magnet, it may be adhered to the clamp surface, which may cause injury of fingers or hands.

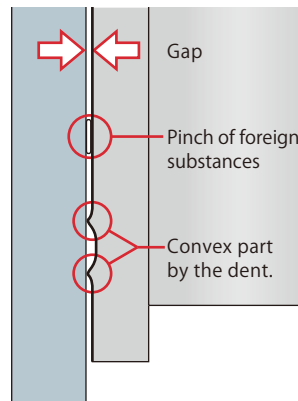

- Be sure to use an mold plate of which thickness is 25 mm or more. Although the projecting height of magnetic flux is around 20 mm, the following cautions should be considered when a mold plate is thinner than 25 mm.
 - ① The clamping force may become decreased.
 - ② The sensor which is easy to be influenced by magnetism has a possibility of malfunction.
 - ③ In case a moving parts is located within 25 mm above the mold displacement detection core, it may cause a malfunction of the mold displacement detection sensor.

Setting error of the ejector

Ejector setting error is a critical cause of the mold fall. A caution plate is provided for machine operators so that the operators can check the mounted position of ejector pin, stroke and displacement of pin hole.

- Caution plate

Pascal mag clamp

Check the following points to avoid the mold to fall.

- If ejector pin is incorrectly positioned, the mold may be pushed to fall.
- When confirming, lift the mold and move the ejector pin manually.

① Wrong Position

Is the position of ejector pin CORRECT?

② Over-stroke

Isn't the length of ejector pin TOO LONG?

③ Displacement of Pin Hole

Does the mold mount PROPERLY?

Recommended Ejector Setting Value

Ejector force should be less than 1/3 against magnetic clamping force on movable platen side.

Ejector speed should be less than 50 mm/sec.

Pascal

PA-236E (付)-1 2012.12

In case of using the heat insulating plate

Mount position	Between the platen and clamp plate	Between the mold and mold plate	Between the mold plate and clamp plate
Availability	○	○	Not available
Specifications of clamp plate	Heat proof type	* 0 ~ 80°C→Standard specifications 0 ~ 150°C→Heat proof type 0 ~ 180°C→Heat proof type	

* : It indicates the temperature transmitted to the mold plate.

Available
Between machine platen and clamp plate

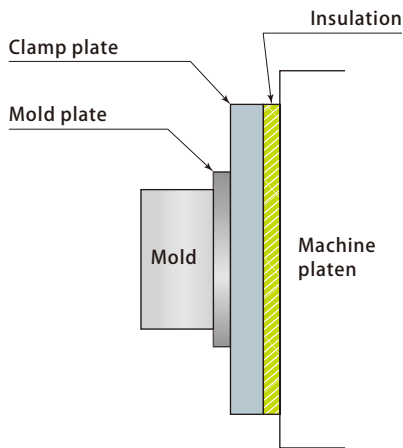

Available
Between mold and mold plate

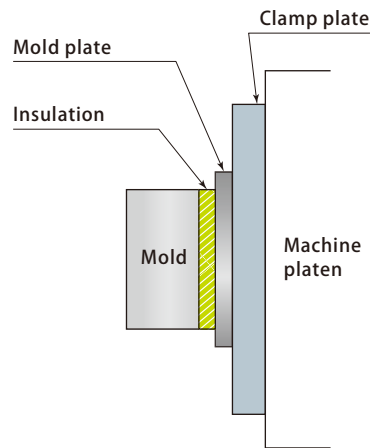

Not available
Between mold plate and clamp plate

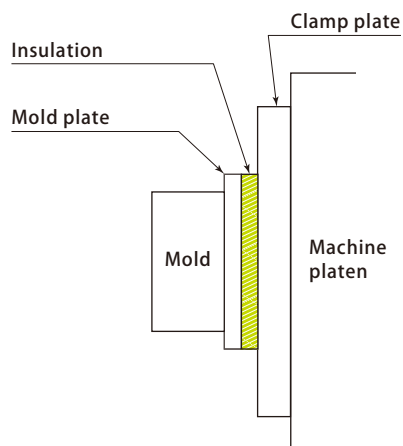

Calculation of rated clamping force

The clamping force of Mag clamp (the adhering force of magnetic clamp) varies according to the area size (number of magnet core) where the mold plate and clamp plate contact. When loading a small mold of which mold plate does not contact all the magnet cores, the rated clamping force is obtainable by the calculation formula shown below. Refer to the following calculation example.

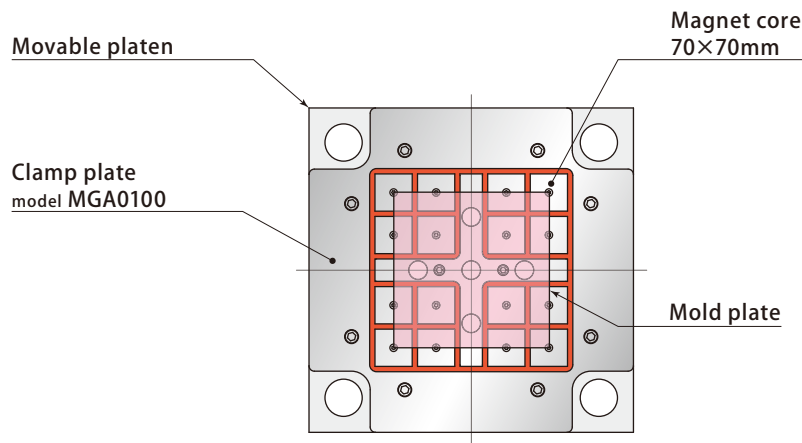

Example : Clamp plate model MGA0100 (movable side)

1. Magnet cores that the mold plate contacts with its entire area = 4 pcs
2. Magnet cores that the mold plate contacts with 1/2 of its area = 8 pcs
3. Magnet cores that the mold plate contacts with 1/4 of its area = 4 pcs
4. Total magnet cores that the mold plate contacts

$$= 4 \text{ pcs} + 8 \text{ pcs} \times 1/2 + 4 \text{ pcs} \times 1/4 = 9 \text{ pcs}$$

5. Clamping force per magnet core = 7.35 kN/pcs
6. Rated clamping force = 7.35 kN/pcs \times 9 pcs = 66.15 kN

- If there is a hole or notch at the bottom of mold plate, deduct the respective area from the total contact area (number of magnet core).
- The actual clamping force may be less than the rated force according to the conditions of mold plate.

(Regarding to the decline of clamping force refer to **page \rightarrow 86**)

Decline of clamping force

According to the conditions of mold plate for the mold, the actual clamping force may become less than the rating. Before using mag clamp, be certain to calculate and acknowledge the decline of clamping force referring to the below tables and charts. And be sure to use in the strict condition that the actual clamping force is larger than the mold opening force of injection molding machine.

$$(\text{Actual clamping force}) = (\text{Rated clamping force} - \text{Reduced force}) \geq (\text{Mold opening force of injection molding machine})$$

If the actual clamping force is not sufficient, replace the mold plate to a larger one to increase the contact area on the clamp plate.

Material of mold plate

Material	Clamping force
SS400 SS55C S45C-H *	100% (rated)
S45C	95%
SK3 SUJ *	85%
SUS430 FC250 FCD600 *	80%
SKH51 SKD11	70%

Surface of mold plate

Surface roughness (Max. height and surface roughness Rz)	Clamping force
Rz1.6 ~ 3.8	100% (rated)
Rz7.5 ~ 15.5	approx.100%
Rz85 ~ 150	approx.90%

The clamping force declines according to the grade of surface roughness in contact with the mold plate and clamp plate.

The clamping force declines according to the materials of mold plate. S45C-H, SUJ, and FCD600 tends to be hard to come off at unclamping because the residual magnetic flux on the mold affects this however it should be improved once the clearance is created between the mold plate and clamp plate.

Distance between two plates (mm)

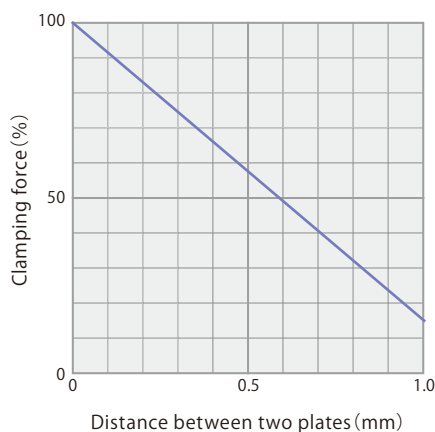

A dent or deformation of the mold plate creates a distance to the clamp plate, which will decrease the clamping capacity significantly.

Temperature of mold plate

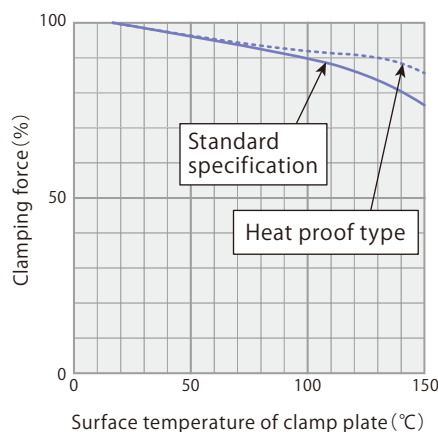

If the temperature of mold plate becomes high, the clamping force significantly decreases. Keep the mold plate temperature below 80°C while it is clamped.