

Work positioning cylinder

Double acting 7 MPa

model **CEK**



X & Y axes positioning model CEK-A



θ axis positioning model CEK-B

X & Y axes positioning

model **CEK-A** □ PAT. θ axis positioningmodel **CEK-B** □ PAT.

Enables high accuracy positioning of the workpiece
and maintains machining accuracy under between operations.

Repeatability: within 5 μ m

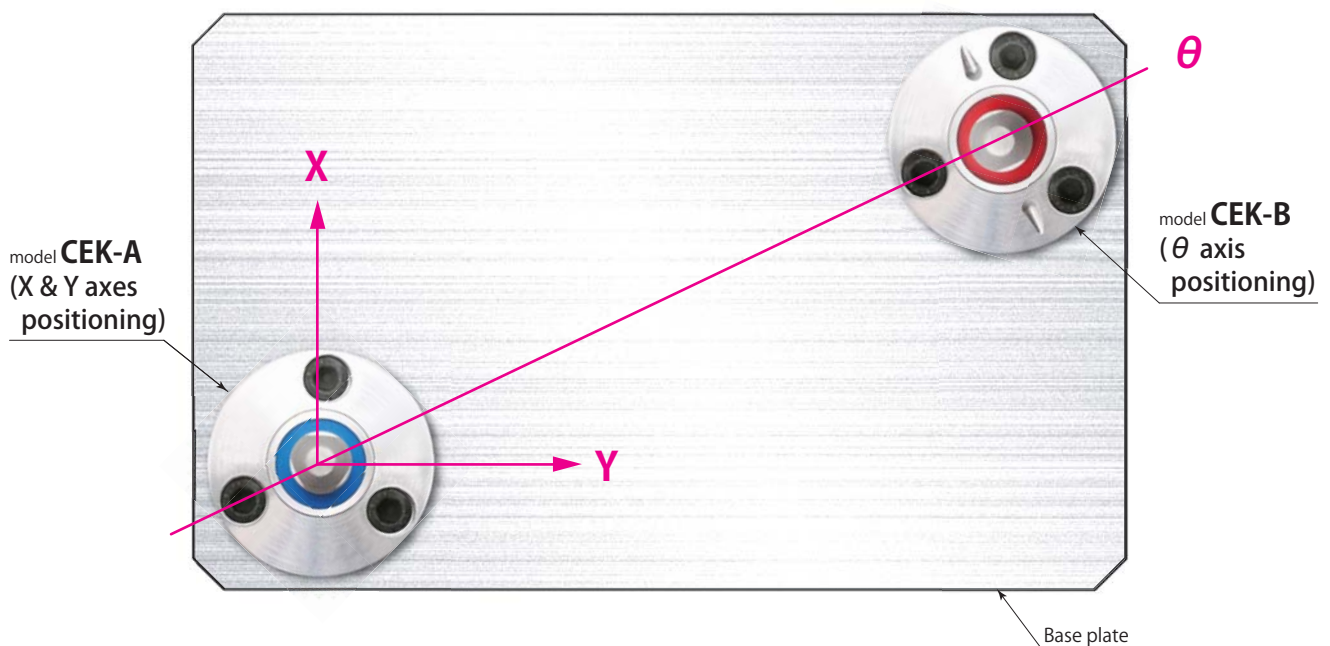

XY axes and θ axis constraint allow high accuracy positioning.

Specifications page → 182

Dimensions page → 184

Mounting details page → 186

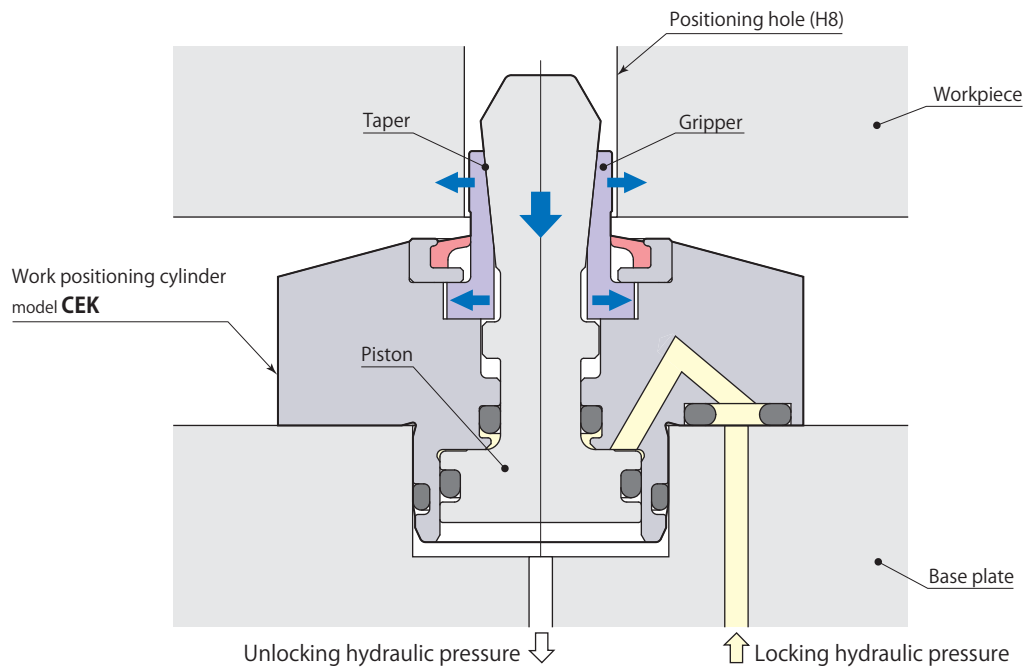
Gripper expansion

A piston lowers by locking hydraulic pressure then a gripper expands horizontally along the taper face of the piston.

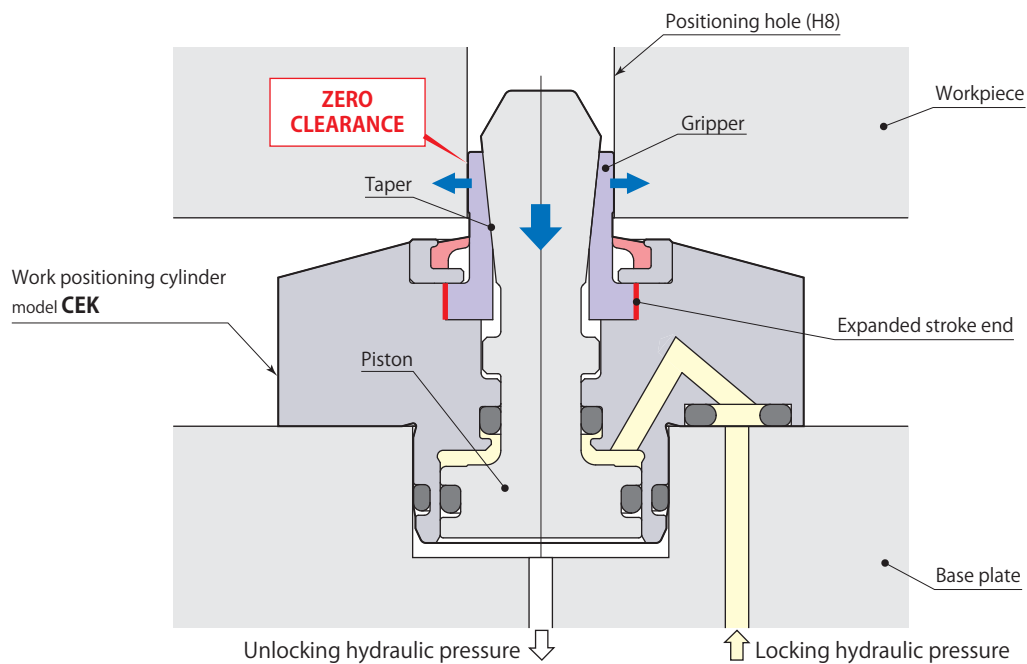
Workpiece positioning

The gripper deforms elastically in radial direction when it comes to the stroke end and the clearance between hole and the gripper is infilled by the deformation, which ensures accurate positioning.

Enables workpiece change smooth**Clearance : 0.2mm**

Enough clearance to make the change quick and easy

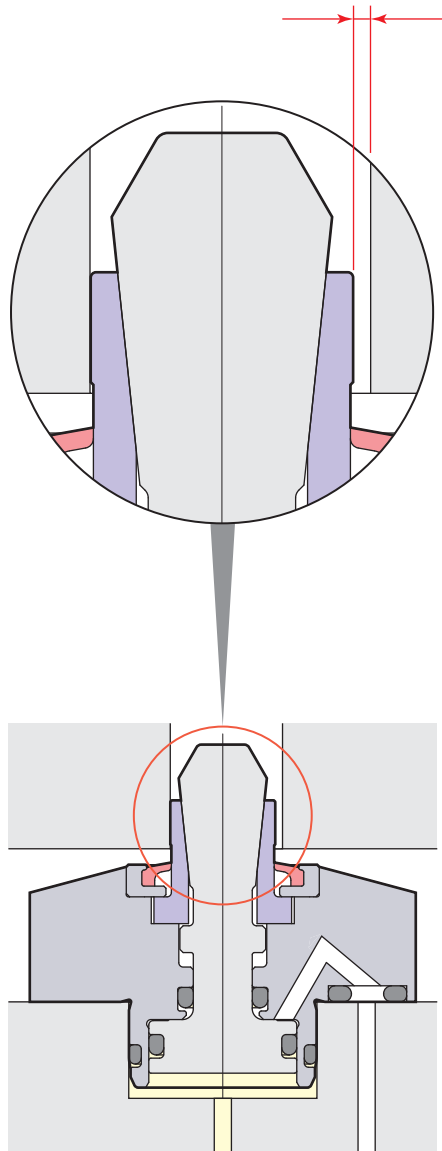
**Work positioning cylinder**

Model CEK has long expansion stroke to make an enough clearance (0.2mm) to change the workpiece easily and quickly.

Clearance : 0.01–0.03mm

Difficult to change due to very small clearance

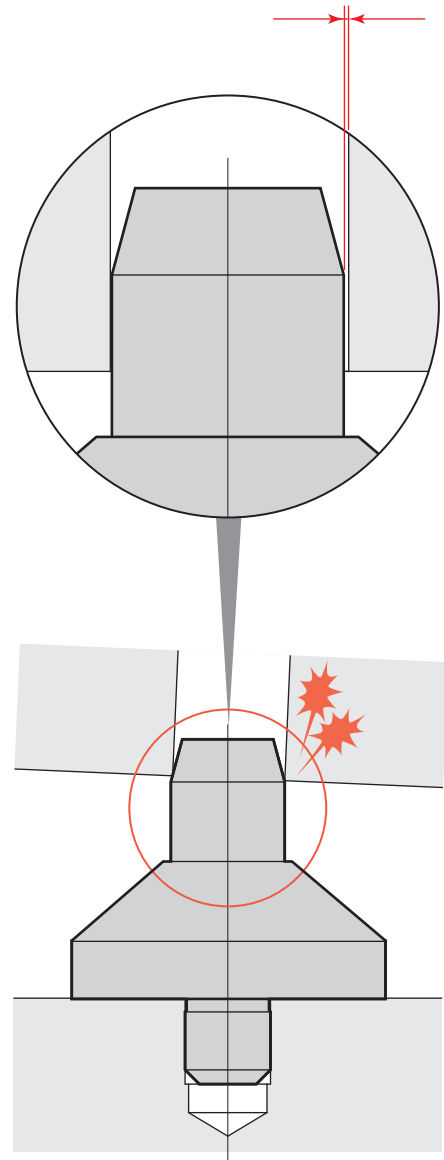
**Positioning pin**

A positioning pin requires very small clearance to achieve accurate positioning, which makes it difficult to engage or disengage the pin.

Do not have an impact on gripper and piston since it employs many parts and has less strength than positioning pin.

Positioning hole pitch error can be tolerated

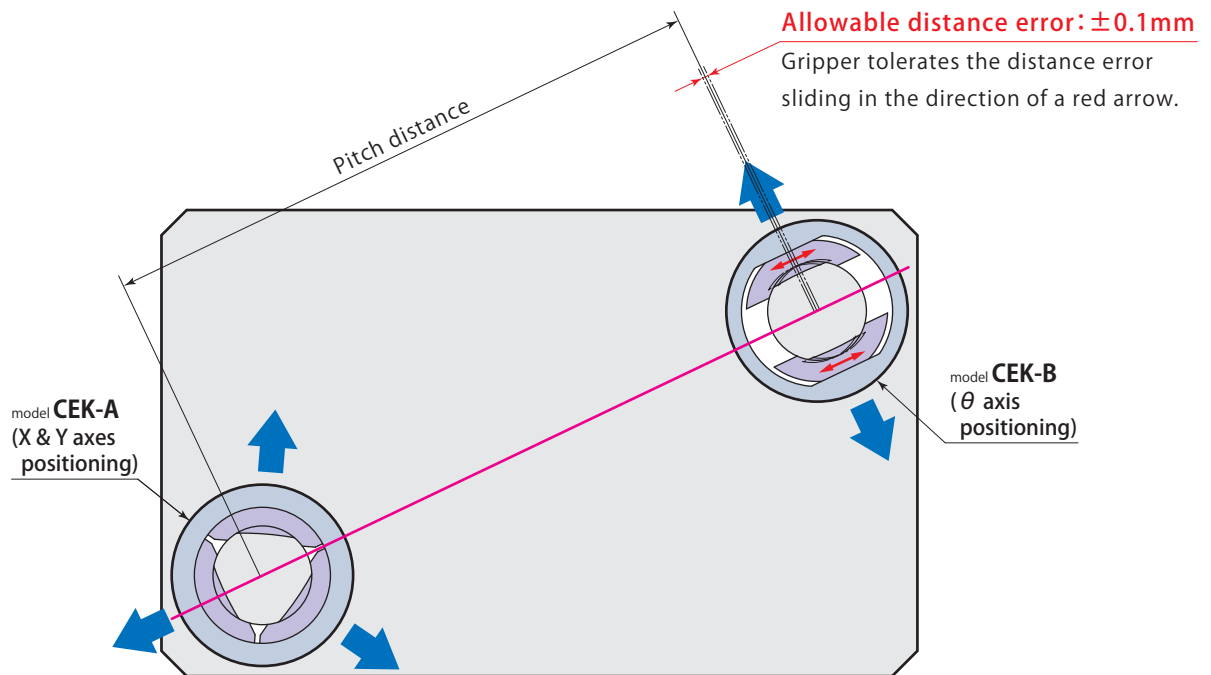

Incorporating strong air blow circuit

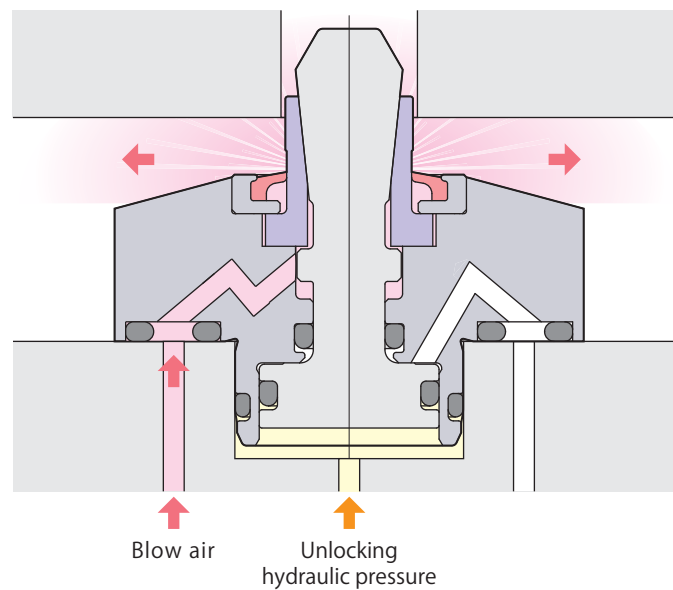

Air blows out from the gap between rod, gripper and scraper to protect the positioning hole from the intrusion of chips and coolant.

Specifications

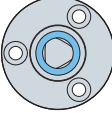
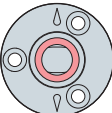
| Type | Size | Positioning hole diameter | | | | |
|---|-----------|---------------------------|-----------|-----------|-----------|-----------|
| A : X & Y axes positioning  | 01 | 08 | 09 | 10 | 11 | 12 |
| | 02 | 13 | 14 | 15 | 16 | |
| B : θ axis positioning  | 03 | 17 | 18 | 19 | 20 | |

| Model | | CEK-A01- <small>Positioning hole diameter</small> | CEK-A02- <small>Positioning hole diameter</small> | CEK-A03- <small>Positioning hole diameter</small> | |
|--|---------------------------|---|---|---|------|
| | | CEK-B01- <small>Positioning hole diameter</small> | CEK-B02- <small>Positioning hole diameter</small> | CEK-B03- <small>Positioning hole diameter</small> | |
| Positioning hole diameter | mm | 8-12 | 13-16 | 17-20 | |
| Radial expansion force | Hydraulic pressure 2.5MPa | kN | 1.21 | 1.78 | 2.52 |
| | Hydraulic pressure 5MPa | kN | 2.43 | 3.56 | 5.03 |
| | Hydraulic pressure 7MPa | kN | 3.40 | 4.99 | 7.05 |
| Full stroke | mm | 1.35 | 1.35 | 1.4 | |
| Cylinder capacity | Lock | cm ³ | 0.17 | 0.25 | 0.37 |
| | Unlock | cm ³ | 0.20 | 0.32 | 0.47 |
| Allowable distance error*1 | mm | ±0.1 | | | |
| Repeatability | μm | 5 | | | |
| Recommended air blow pressure | MPa | 0.3-0.4 | | | |
| Mass | kg | 0.10 | 0.14 | 0.21 | |
| Recommended tightening torque of mounting screws*2 | N·m | 3.6 | 3.6 | 7.2 | |

● Pressure range: 2.5-7 MPa ● Proof pressure: 10.5 MPa ● Operating temperature: 0-70 °C

● Fluid used: General mineral based hydraulic oil (ISO-VG32 equivalent)

*1: This is value when CEK-A and CEK-B are used in combination. The value is achievable only when CEK-A and CEK-B are used together.

*2: ISO R898 class 12.9

Hydraulic and pneumatic circuit diagram

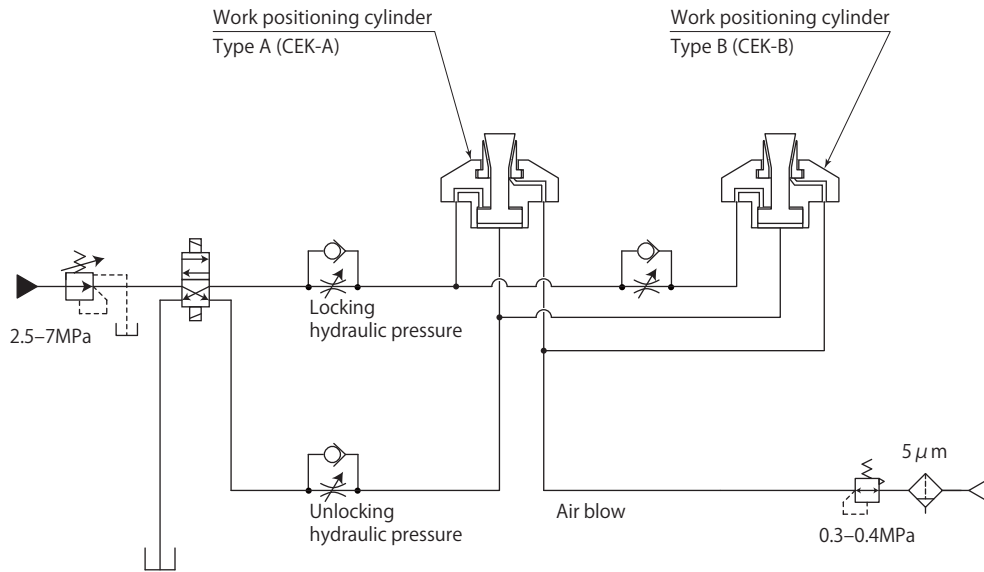

For stable positioning accuracy, the circuit should be built to have Type A actuate first.

Flow control valve mounting example

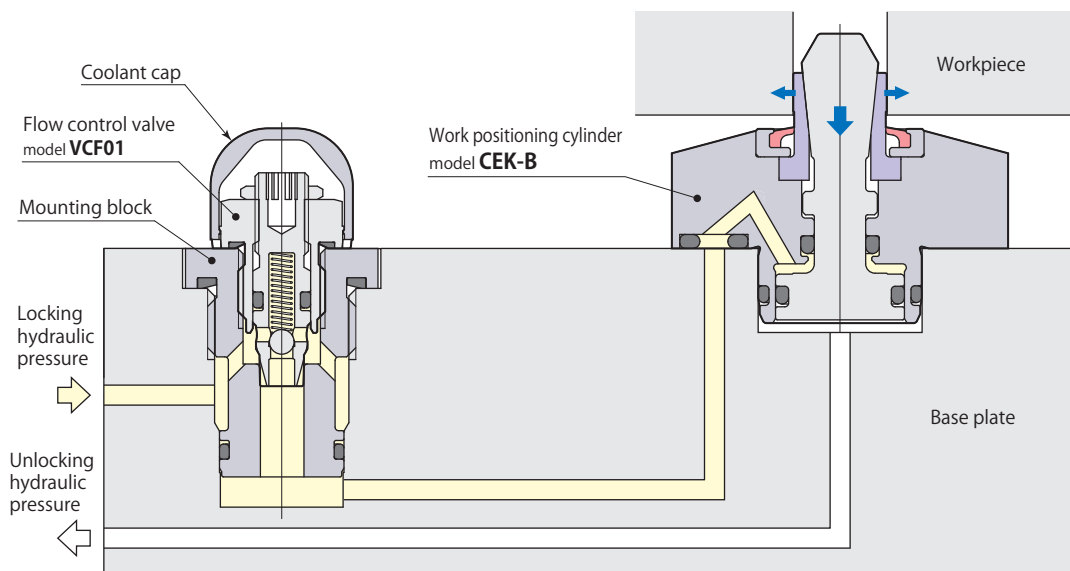

Refer to **page →170** for details on flow control valve model VCF.

Dimensions

CEK-A

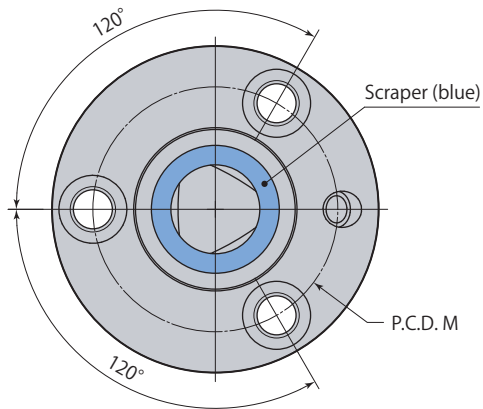

CEK-B

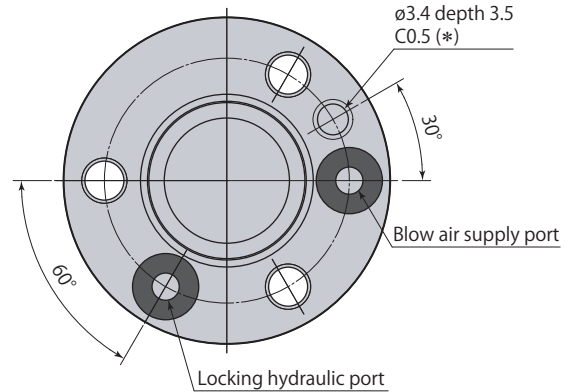
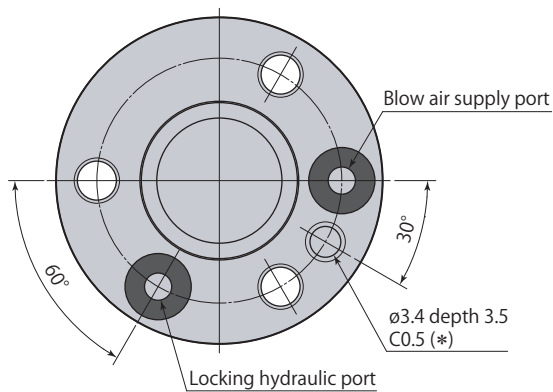
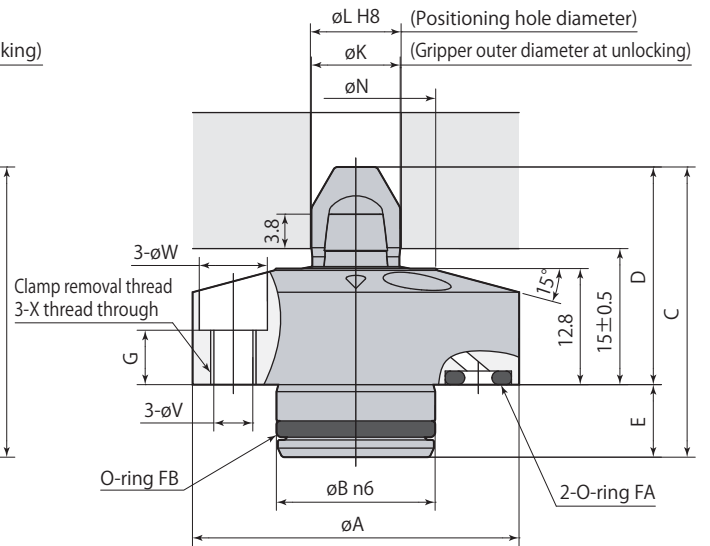
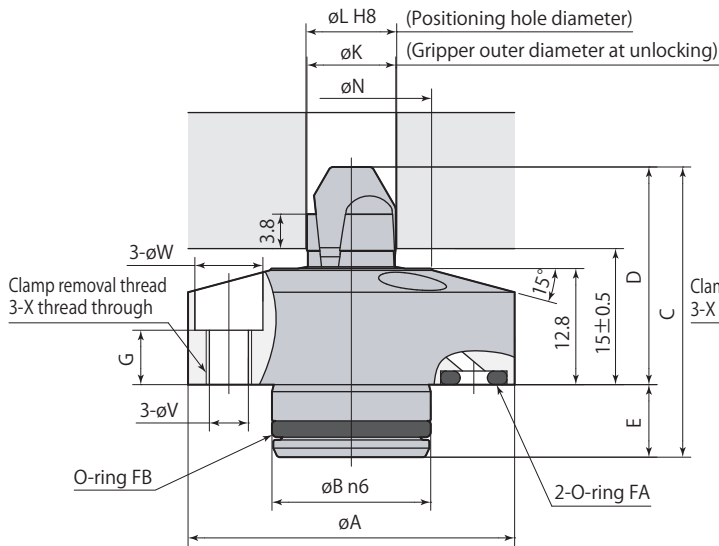
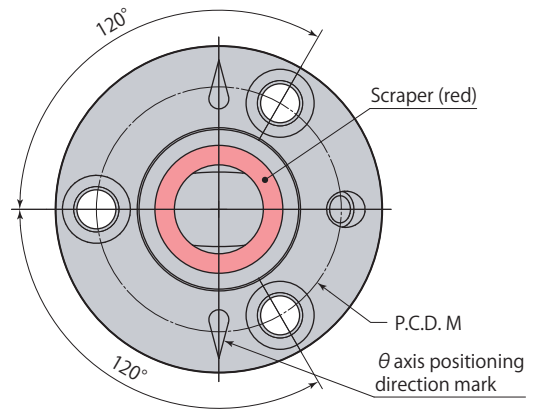

* : Positioning pin is used to prevent positioning mistake (recommended positioning pin : Spring pin $\phi 3 \times 8$).

Work positioning cylinder

CEK

mm

| Model | CEK-A01 - Positioning hole diameter | | | | | CEK-A02 - Positioning hole diameter | | | | CEK-A03 - Positioning hole diameter | | | |
|--|--|------------------------------------|-------------------------------------|-------------------------------------|-------------------------------------|--|-------------------------------------|-------------------------------------|-------------------------------------|--|-------------------------------------|-------------------------------------|-------------------------------------|
| | CEK-B01 - Positioning hole diameter | | | | | CEK-B02 - Positioning hole diameter | | | | CEK-B03 - Positioning hole diameter | | | |
| Positioning hole diameter | 8 | 9 | 10 | 11 | 12 | 13 | 14 | 15 | 16 | 17 | 18 | 19 | 20 |
| øA | 36 | | | | | 40 | | | | 47 | | | |
| øB | 17.5 ^{+0.023} / _{+0.012} | | | | | 21 ^{+0.028} / _{+0.015} | | | | 26 ^{+0.028} / _{+0.015} | | | |
| C | 32 | | | | | 35 | | | | 38 | | | |
| D | 24 | | | | | 25 | | | | 26 | | | |
| E | 8 | | | | | 10 | | | | 12 | | | |
| G | 6 | | | | | 6 | | | | 5 | | | |
| øK | 7.8 | 8.8 | 9.8 | 10.8 | 11.8 | 12.8 | 13.8 | 14.8 | 15.8 | 16.8 | 17.8 | 18.8 | 19.8 |
| øL | 8 ^{+0.022} / ₀ | 9 ^{+0.022} / ₀ | 10 ^{+0.022} / ₀ | 11 ^{+0.027} / ₀ | 12 ^{+0.027} / ₀ | 13 ^{+0.027} / ₀ | 14 ^{+0.027} / ₀ | 15 ^{+0.027} / ₀ | 16 ^{+0.027} / ₀ | 17 ^{+0.027} / ₀ | 18 ^{+0.027} / ₀ | 19 ^{+0.033} / ₀ | 20 ^{+0.033} / ₀ |
| M | 27 | | | | | 31 | | | | 36 | | | |
| øN | 18 | | | | | 22 | | | | 25.6 | | | |
| øV | 4.3 | | | | | 4.3 | | | | 5.5 | | | |
| øW | 7.5 | | | | | 7.5 | | | | 9 | | | |
| X | M5×0.8 | | | | | M5×0.8 | | | | M6×1 | | | |
| O-ring FA (fluorocarbon hardness Hs90) | P4 | | | | | P4 | | | | P4 | | | |
| O-ring FB (fluorocarbon hardness Hs90) | S15 | | | | | S18 | | | | AS568-020 | | | |

- The diagram indicates unlocked condition.
- Mounting screws, positioning pin are not included.
- Use øA for positioning measurement after mounting.

Mounting details

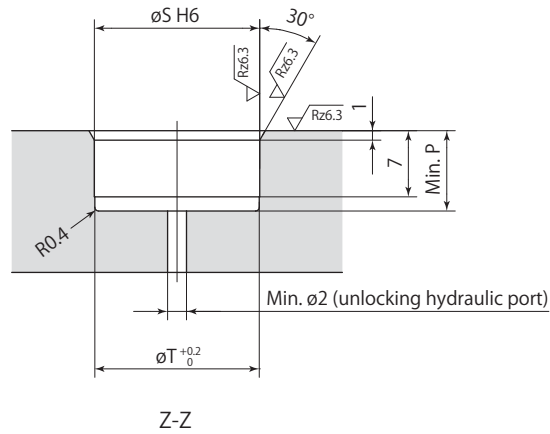
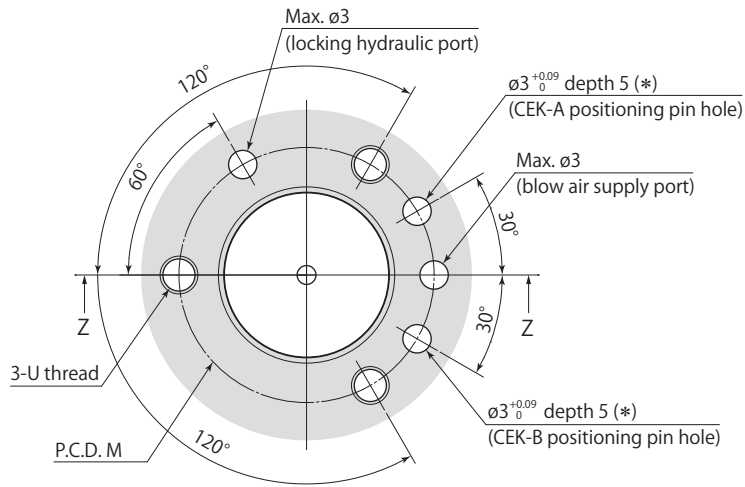

Rz: ISO4287(1997)

* : Positioning pin is used to prevent positioning mistake (recommended positioning pin : Spring pin ø3×8).

mm

| Model | CEK-A01 - Positioning hole diameter | CEK-A02 - Positioning hole diameter | CEK-A03 - Positioning hole diameter |
|-------|---------------------------------------|-------------------------------------|-------------------------------------|
| | CEK-B01 - Positioning hole diameter | CEK-B02 - Positioning hole diameter | CEK-B03 - Positioning hole diameter |
| M | 27 | 31 | 36 |
| P | 8.5 | 10.5 | 12.5 |
| øS | 17.5 ^{+0.011} / ₀ | 21 ^{+0.013} / ₀ | 26 ^{+0.013} / ₀ |
| øT | 17.3 | 20.8 | 25.8 |
| U | M4 | M4 | M5 |