

IMM vertical loading

Slidable type

Hydraulic model **TYA** page → 28
 model **TYB** page → 29
 model **TYJ** page → 30

Air model **TLC** page → 51

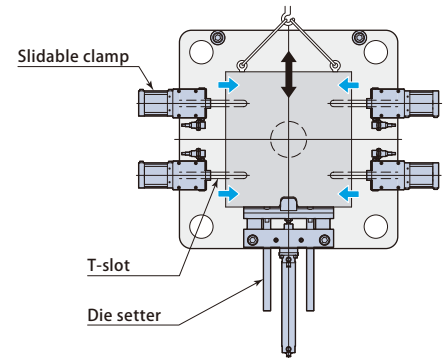

Mold plate thickness	Mold plate width	T-slot
Unified	Not unified	With T-slot

- Refer to page → 68, regarding the unification of mold plate thickness.

Automatic slidable type

Hydraulic model **TYC-Z/R** page → 35

Air model **TLC-Z/R** page → 55

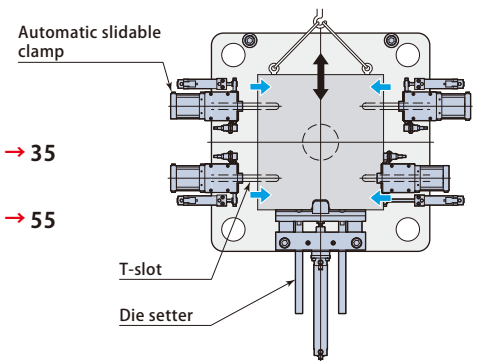

Mold plate thickness	Mold plate width	T-slot
Unified	Not unified	Without T-slot

- Refer to page → 68, regarding the unification of mold plate thickness.

T-slot-less slidable type

Hydraulic model **TYA-M** page → 39

Air model **TLA-M** page → 59

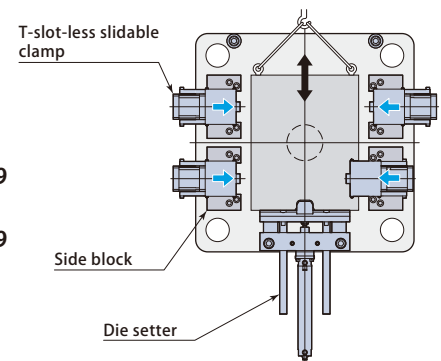

Mold plate thickness	Mold plate width	T-slot
Unified		—

Bolted type

For small and medium-sized IMM

Hydraulic model **TME** page → 43

For medium and large-sized IMM

Hydraulic model **TKB** page → 47

Air model **TLA** page → 63

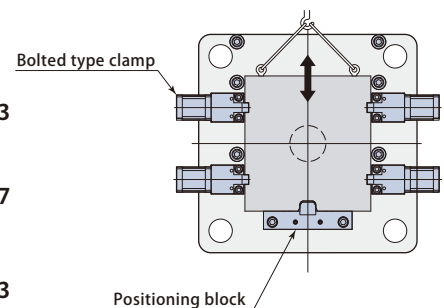

Mold plate thickness	Mold plate width	T-slot
Not unified		—

Mag clamp

It clamps mold instantly with strong everlasting magnet (neodymium magnet, alnico magnet). It is unnecessary to unify the "thickness" and "width" of mold plate.



* It is not mentioned in this catalogue. Contact Pascal for the details.

IMM horizontal loading

Mold plate thickness	Mold plate width	T-slot
Unified		—

Mold plate thickness	Mold plate width	T-slot
Not unified		—

Bolted type clamp

For small and medium-sized IMM

Hydraulic model **TME** page → 43

For medium and large-sized IMM

Hydraulic model **TKB** page → 47

Air model **TLA** page → 63

Mag clamp

The introduction of automatic clamp by IMM horizontal loading needs the unification of "thickness" and "width" of mold plate.

In case that it is not unified, it can be applied with the mag clamp.

* It is not mentioned in this catalogue. Contact Pascal for the details.

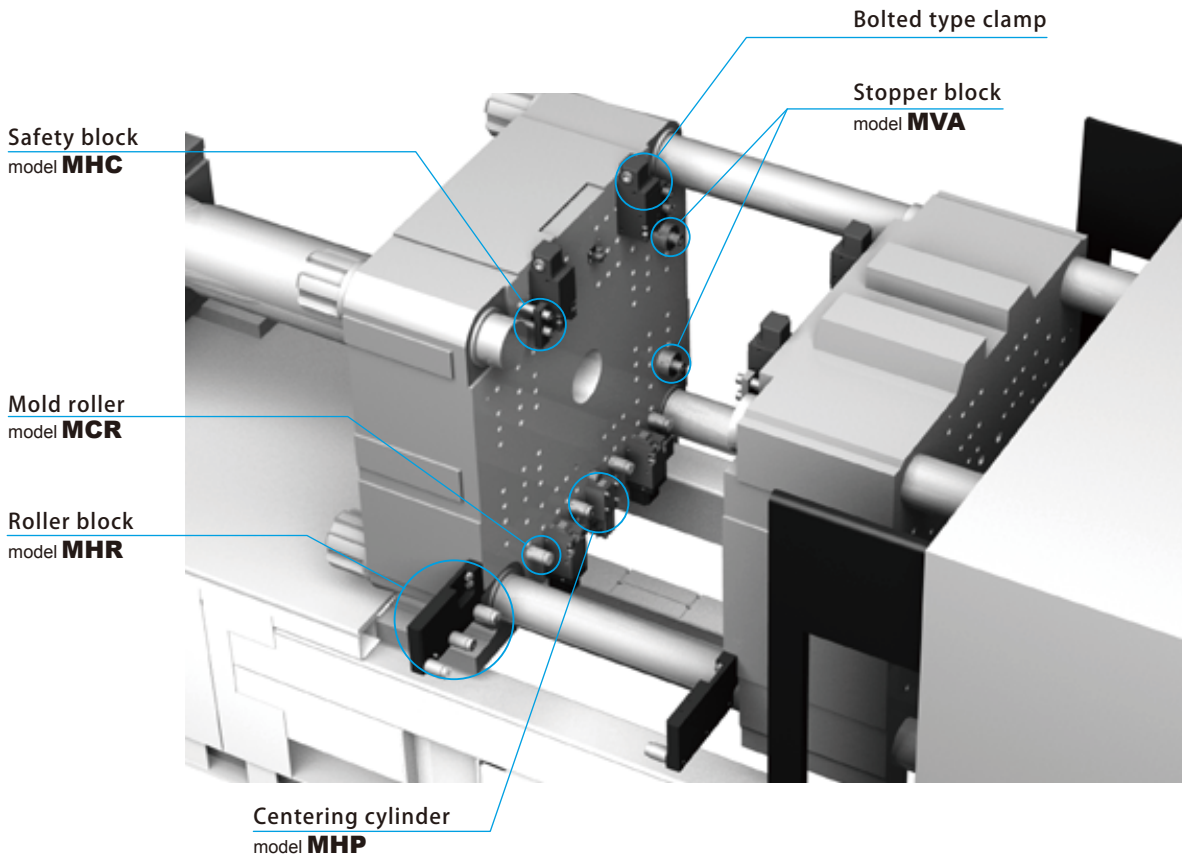

Selecting table for mold roller, centering cylinder, stopper block and safety block.

IMM Mold clamping force kN	~500	~1000	~2000	~3500	~4500	~5500	~6500	~8500	~10000	~13000	~20000	~25000	~30000
Mold roller	MCR020K	MCR040K	MCR060K	MCR080K		MCR100K		MCR120K	MCR160K	MCR180K			
Centering cylinder	MHP1		MHP2			MHP3			MHP4				
Stopper block	MVA030	MVA040	MVA060		MVA080			MVA100					
Safety block	MHC08	MHC12	MHC16	MHC20	MHC24		MHC30						

Selection of mold clamping system

For small and medium-sized IMM

Hydraulic model **TME**

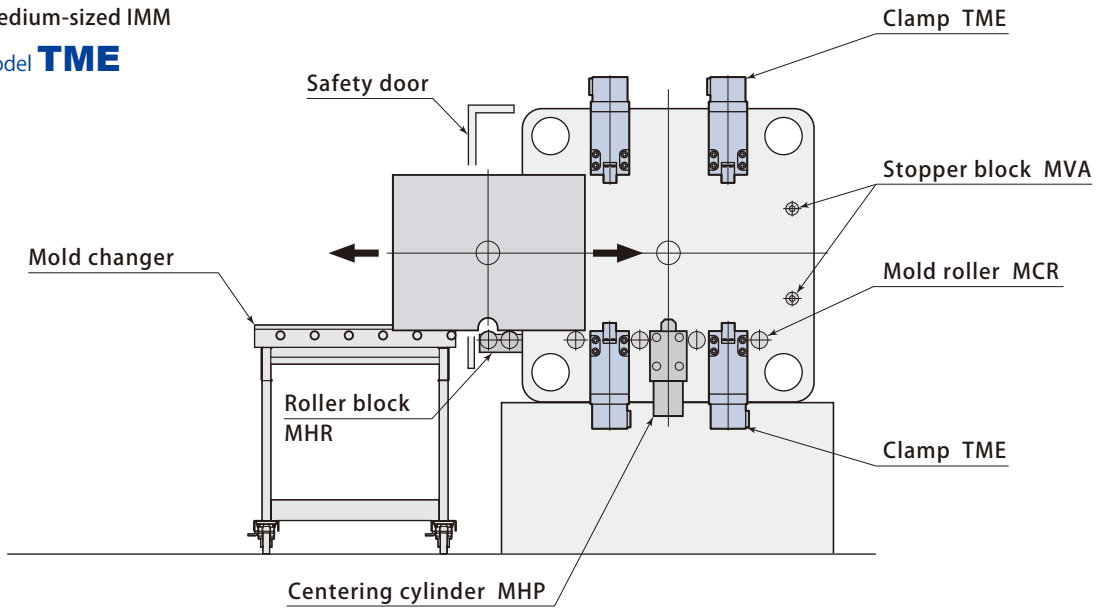

For medium and large-sized IMM

Hydraulic model **TKB**

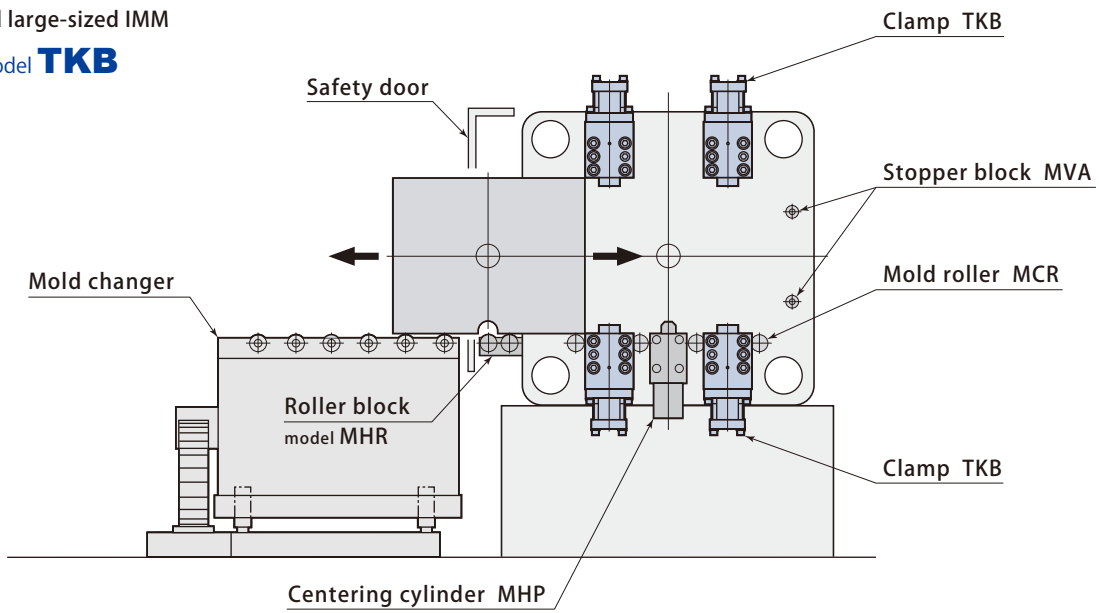

For small, medium and large-sized IMM

Air model **TLA**

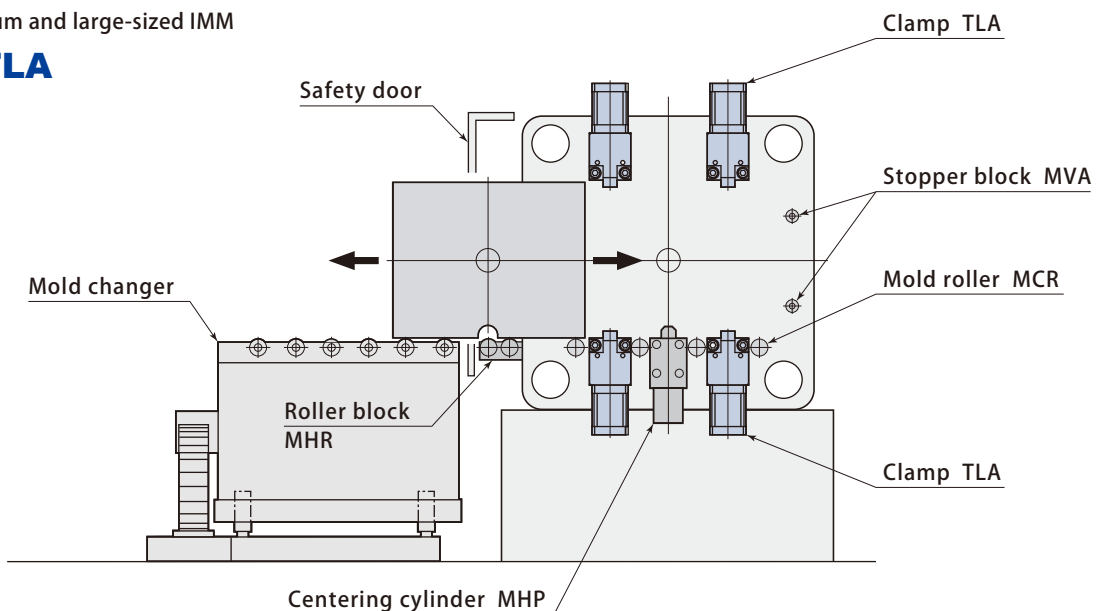

Selection of mold clamping system

Selection of mold clamping system

Hydraulic

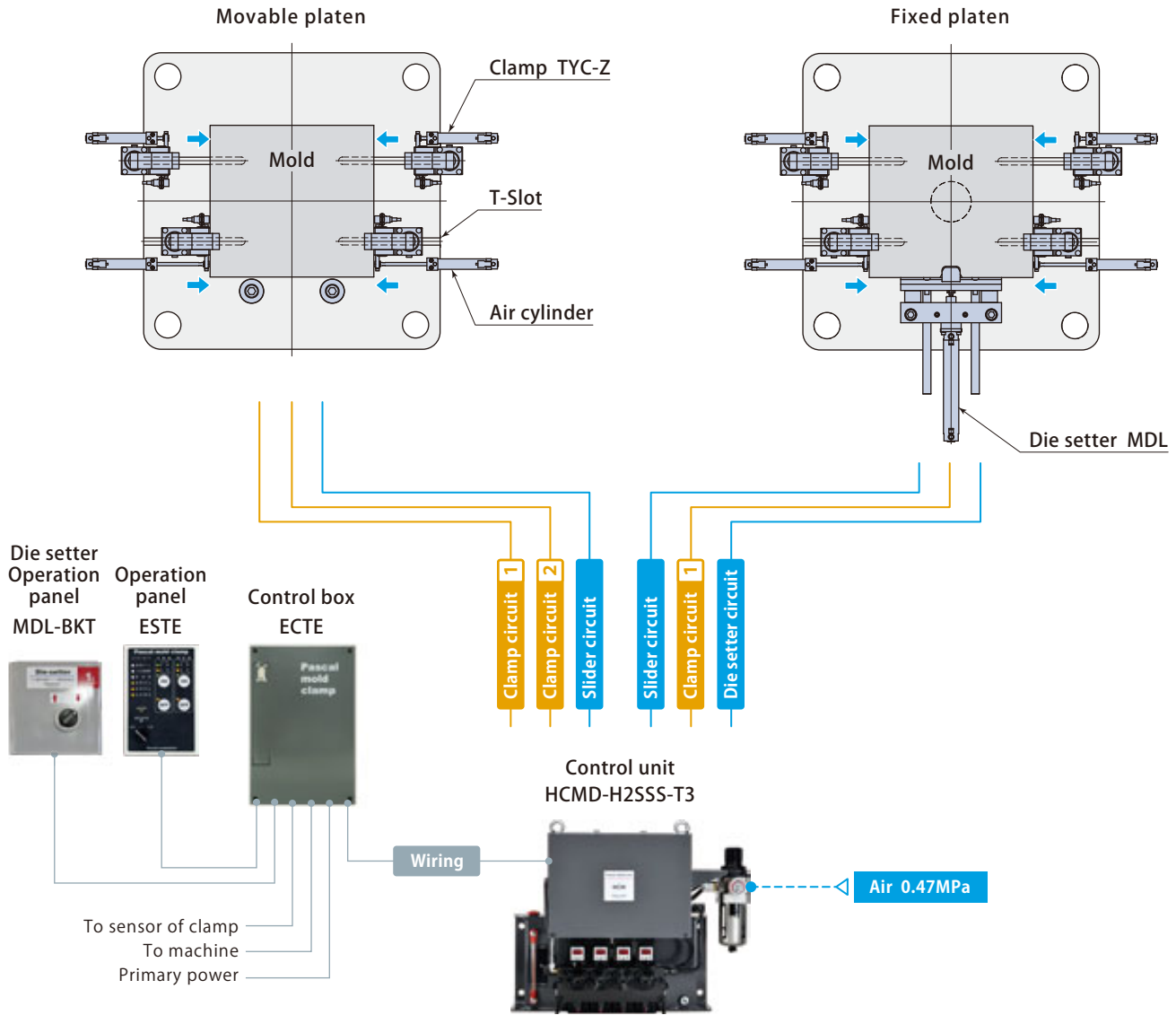

Selecting table for hydraulic clamp and control unit

IMM	Mold clamping force kN	~500	~1000	~1500	~2000	~3500	~5500	~6500	~8500	~13000	~30000	~35000
	Mold opening force kN	40	80	100	160	250	400	640(400)	640	1000	1600	2000
TYA TYB TYJ TYA-M	Hydraulic clamp (Fixed platen/ movable platen each 4)	TYA010 TYA010M	TYA020 TYA020M	TYA040 TYB040 TYA040M	TYA063 TYB063 TYJ063 TYA063M	TYA100 TYB100 TYJ100 TYA100M	TYA160 TYB160 TYJ160 TYA160M	TYA250 TYB250 TYJ250				
	Control unit	HCMD-H2SSS						HCMD-H22SSS				
TYC-Z	Hydraulic clamp (Fixed platen/ movable platen each 4)		TYC020Z	TYC040Z	TYC063Z	TYC100Z	TYC160Z	TYC250Z				
	Control unit		HCMD-H2SSS-T3						HCMD-H22SSS-T3			
TYC-R	Hydraulic clamp (Fixed platen/ movable platen each 4)		TYC020R	TYC040R	TYC063R	TYC100R	TYC160R	TYC250R				
	Control unit		HCMD-H2SSS-T2						HCMD-H22SSS-T2			
TME TKB	Hydraulic clamp (Fixed platen/ movable platen each 4)	TME010	TME025	TME040	TME063	TME100	TME160 (TME100)	TME160 (TKB160)	TKB250	TKB400	TKB500	
	Control unit	HCMD-H3CSSS			HCMD-H33CSSS		HCEF-3-H3CSSS *					

● The clamping force shall be determined based on the machine mold opening force. Contact Pascal for further assistance if the actual opening force is greater than the values shown in the above table.

● Regarding Control unit, refer to **page → 75**, Die setter **page → 85**, Operation panel **page → 83**, and Control box **page → 84**.

* It is not mentioned in this catalogue. Contact Pascal for the details.

Air

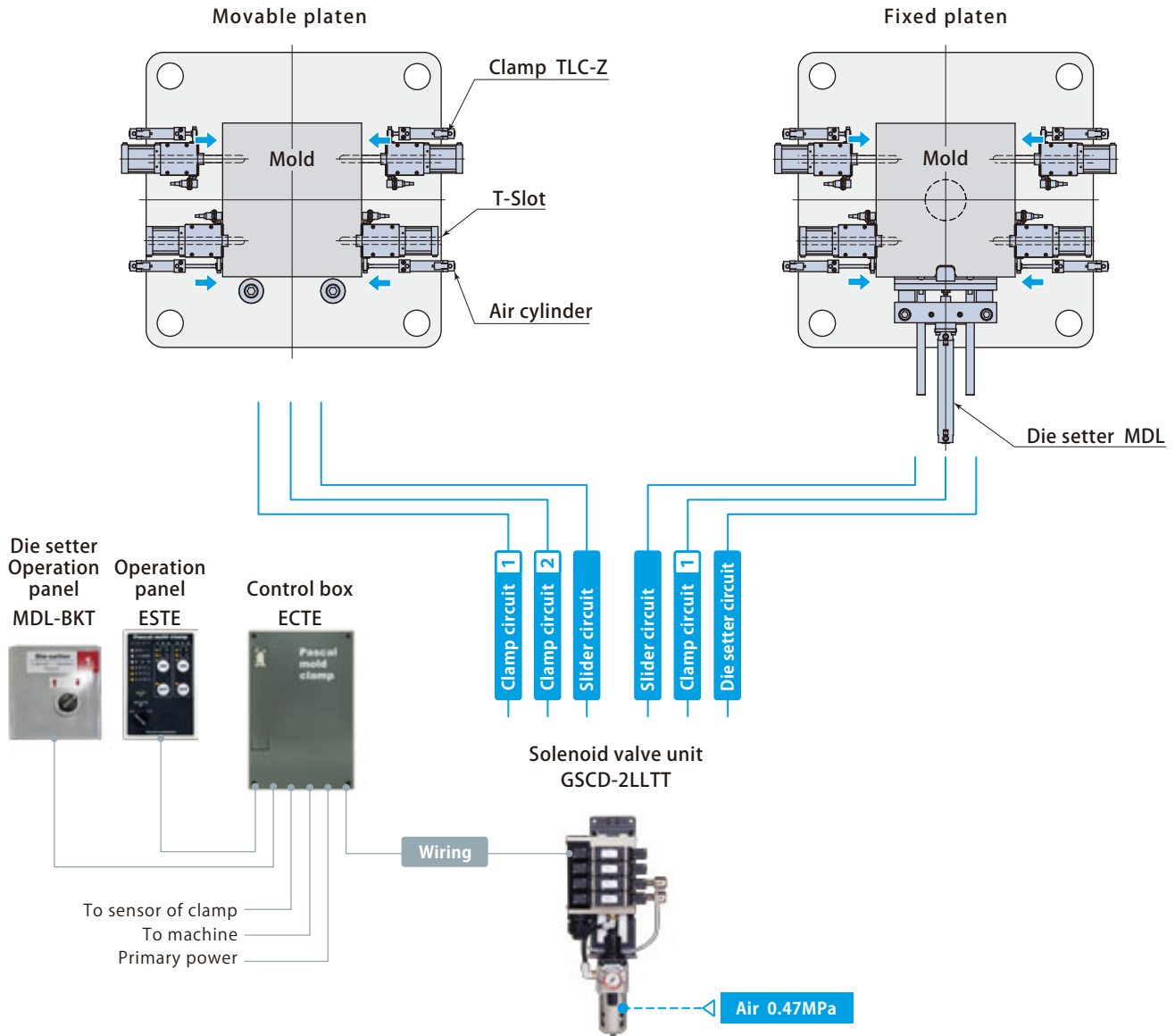

Selecting table for air clamp and solenoid valve unit

IMM	Mold clamping force kN	~500	~800	~1250	~2000	~3500	~5500	~6500	~8500
	Mold opening force kN	40	64	100	160	250	400	640	1000
TLC TLA-M	Air clamp (Fixed platen/ movable platen each 4)	TLC010 TLA010M	TLC016 TLA016M	TLC025 TLA025M	TLC040 TLA040M	TLC063 TLA063M	TLC100	TLC160	
	Solenoid valve unit	GSCD-1LL					GSCD-2LL		
TLC-Z	Air clamp (Fixed platen/ movable platen each 4)	TLC010Z	TLC016Z	TLC025Z	TLC040Z	TLC063Z	TLC100Z	TLC160Z	
	Solenoid valve unit	GSCD-1LLTT					GSCD-2LLTT		
TLC-R	Air clamp (Fixed platen/ movable platen each 4)	TLC010R	TLC016R	TLC025R	TLC040R	TLC063R	TLC100R	TLC160R	
	Solenoid valve unit	GSCD-1LLTT					GSCD-2LLTT		
TLA	Air clamp (Fixed platen/ movable platen each 4)	TLA010	TLA016	TLA025	TLA040	TLA063	TLA100	TLA160	TLA250
	Solenoid valve unit	GSCD-1LL					GSCD-2LL		

- The clamping force shall be determined based on the machine mold opening force. Contact Pascal for further assistance if the actual opening force is greater than the values shown in the above table.
- Regarding Solenoid valve unit, refer to **page → 81**, Die setter **page → 85**, Operation panel **page → 83**, and Control box **page → 84**.