

Die Detecting

Smart sensor checks the mold **DD mag clamp**

The clamp with DD sensor which can numerically check the mold. It can detect the clamp force decrease caused by heat, mold base material and a clearance between the mold and magnet core face.



As for DD mag clamp, the status indicator is added to the control box.



Clamp force indicator

* Mold displacement detection system Refer to **page → 32**

Normal clamping status

The sensor indicates **AA** which means the mold has adequate size, material and temperature are appropriate to clamp and there is no gap between the magnetic surface and mold. 

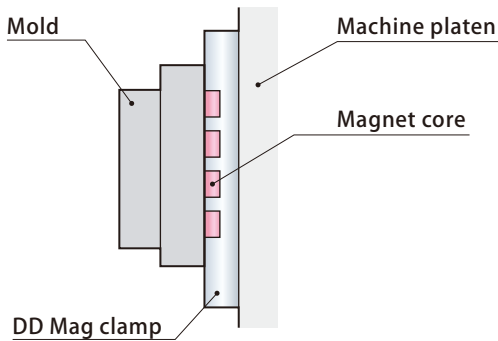

Minimum mold size required to clamp

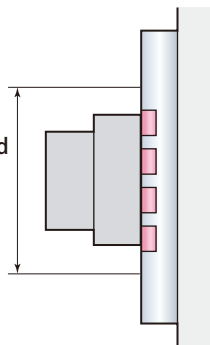

Size detection

Detect **too small** mold

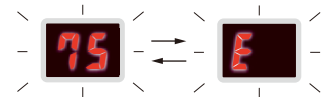

Clamp force kN	Recommended Min. mold size mm
1000	280 × 280
1800	330 × 330
3500	475 × 475
4500	565 × 565
6500	635 × 635
8500	710 × 710
10500	790 × 790
13000	855 × 855

* Contact Pascal for details.

Gap detection

Clamp force decrease due to **the gap**

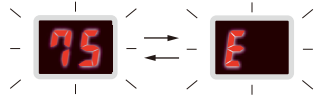

Clearance detection

Clamp force decrease due to **a clearance**

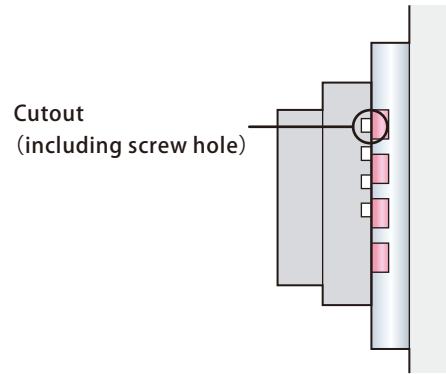
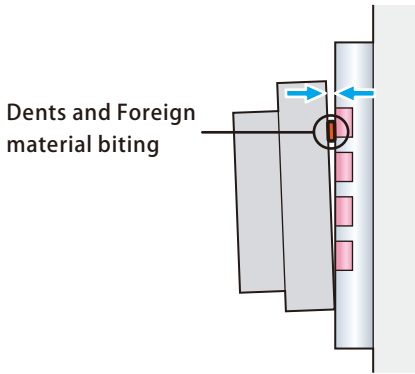
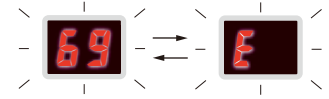

The sensor output abnormal signal when clamp force decreases more than 20% due to gap or clearance.

Material detection

Clamp force decrease due to **the material that are not easily magnetized.**

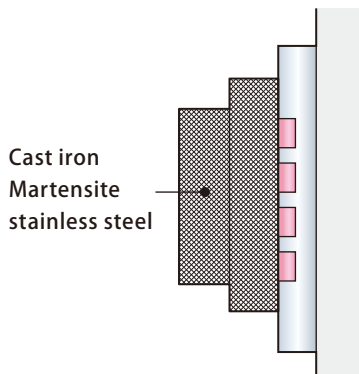

High temperature detection

Clamp force decrease due to **the mold heat-up**

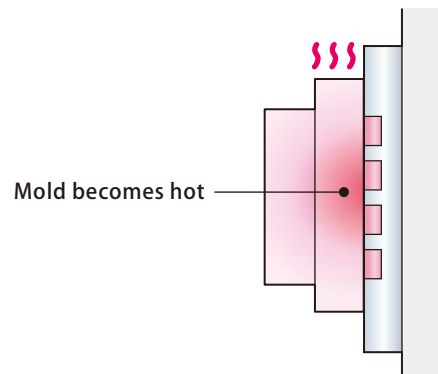

Simply type of material or mold temperature does not make the clamping force decrease lower than 80% however the value goes down due to the force decrease.