

air Pallet clamp

Double acting air

model **RPC** PAT.P.



Air pallet clamp
model RPC

Pascal
www.pascaleng.co.jp

RPC

Pallet clamp

air Double acting

model **RPC** PAT.P.



Easily programmable for assembly and transport

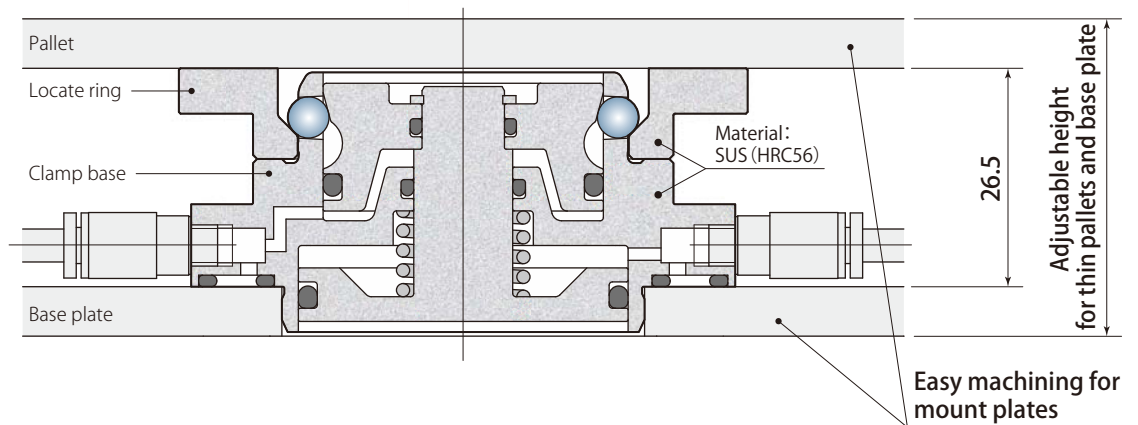

Specifications

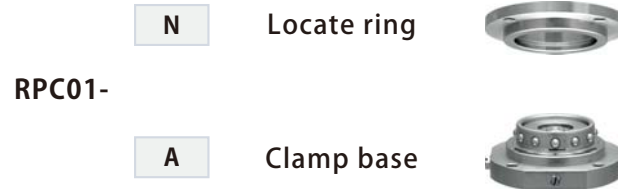

Pressure range		MPa	0.2–0.5
Clamping force	Air pressure 0 MPa	kN	0.09
	Air pressure 0.2MPa	kN	0.56
	Air pressure 0.3MPa	kN	0.79
	Air pressure 0.4MPa	kN	1.02
	Air pressure 0.5MPa	kN	1.25
Clamping force calculation (P: Air pressure MPa)		kN	$2.32 \times P + 0.09$
Cylinder capacity	Clamp	cm ³	4.6
	Unclamp	cm ³	3.2
Full stroke		mm	4.0
Lift stroke		mm	1.0
Lift force	Air pressure 0.2MPa	kN	0.10
	Air pressure 0.3MPa	kN	0.18
	Air pressure 0.4MPa	kN	0.26
	Air pressure 0.5MPa	kN	0.34
Lift force calculation (P: Unclamping air pressure MPa)			$0.79 \times P - 0.06$
Mass	Locate ring	g	115
	Clamp base	g	410
Recommended tightening torque of mounting screws* ¹	M5 Using	N·m	4.0
	M6 Using	N·m	5.9

- Proof pressure: 0.75 MPa
- Operating temperature: 0–70 °C
- Fluid used: Air*²
- Oil supply: Not required
- This product cannot be used in adverse environment where it is exposed to cutting fluid or metal chips.

*1: ISO R898 class 12.9

*2: Supply the dry and filtered air. Particulate size 5 μm or less is recommended.

Pallet setting

- The clamp can be engaged even if the pallet is not leveled. (Allowable tilting angle 5°)
Be careful not to overload the clamp base.

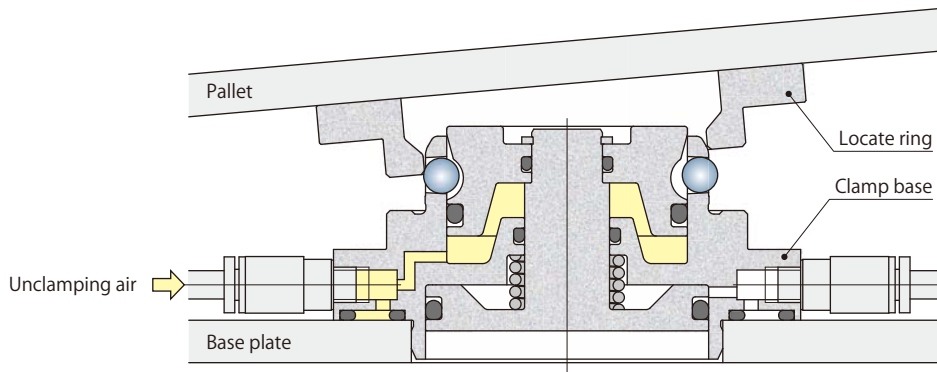

Clamping

- The supplied air to the clamp causes the piston to stroke down and push the steel ball bearing out, substantially lowering the locate ring.

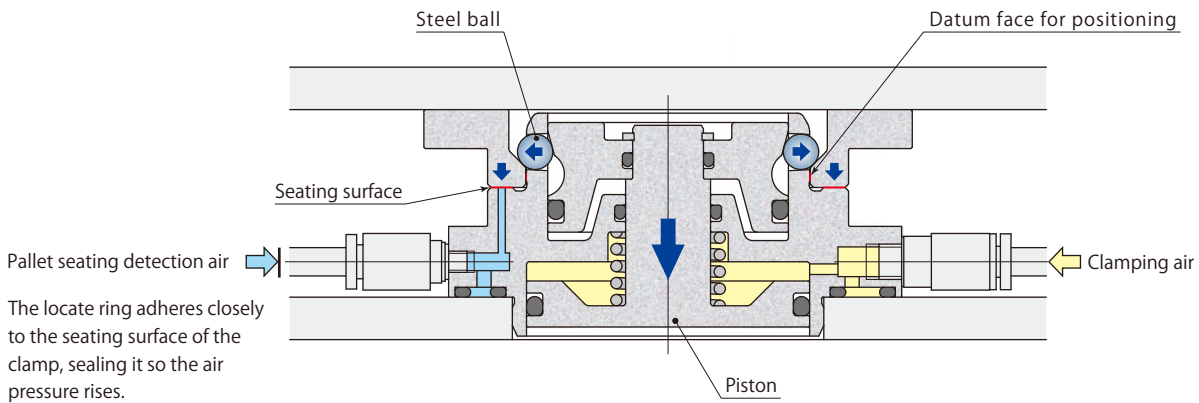

Unclamping

- The piston is pushed up by the unclamping air and the pallet is lifted up by the piston.

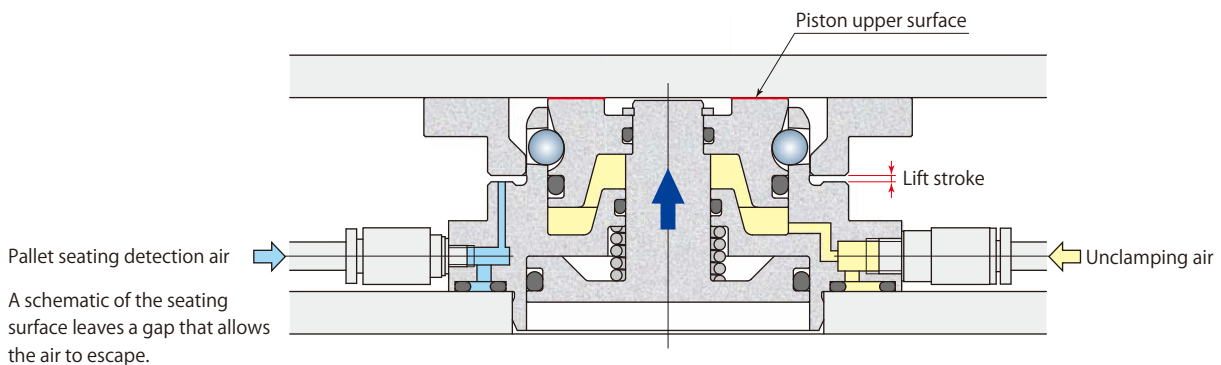

Pneumatic circuit diagram

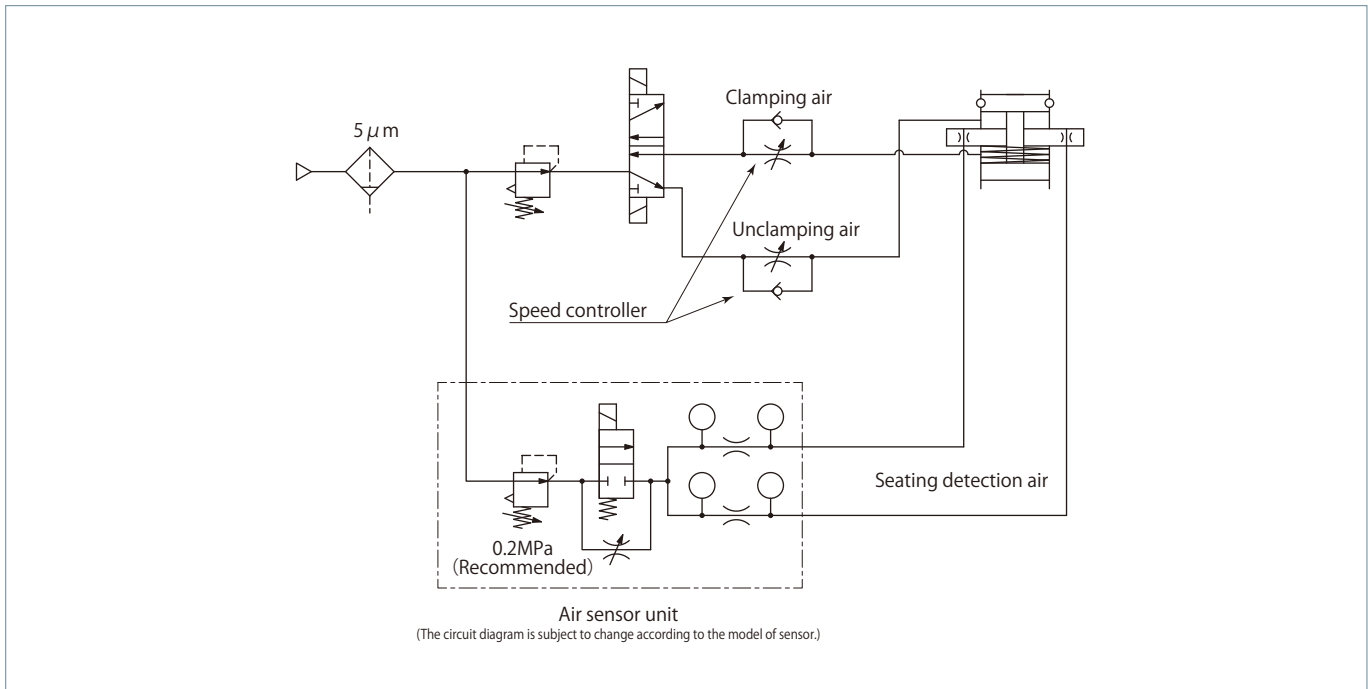

- Adjust full stroking time to be more than 1 second by a speed controller to avoid impact at the time of clamp or unclamp action.

Air sensor unit recommended condition of use

Supplier and model	ISA3-F/G series manufactured by SMC GPS2-05、GPS3-E series manufactured by CKD
Air supply pressure	0.2 MPa
Inner diameter of piping	ø4 mm
Overall piping length	5 m or less

- Supply the dry and filtered air. Particulate size 5 μm or less is recommended.
- Use a solenoid valve with needle for air sensor unit and control it supplying air all the time in order to eliminate intrusion of chips or coolant.

- There is a case that air sensing cannot be made successfully as designed when it is used out of the usage shown on the left. Contact Technical service center for more details.
- Refer to the sensor supplier's instruction manual for the details of setting.
- Sensing performance such as detectable time and pressure differs depending on the supplier and model number of the sensor. Select the right model referring to sensor's application and characteristics.

Piping Method

- The following two options are available according to the jig space.

Direct piping

Piping via plate

- Detach the plug and screw the fitting directly onto the air entry port of the clamp. No need to drill a hole for piping in the plate.

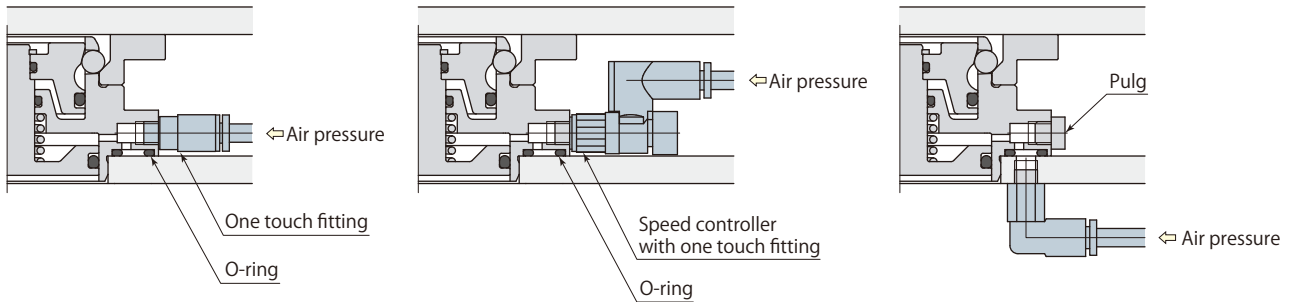

Mounting on the plate

- The clamp can be bolted from either the top or the bottom. Be careful that the thread size varies depending on the direction of the bolt.

Clamp base

Upper surface mounting

Lower surface mounting

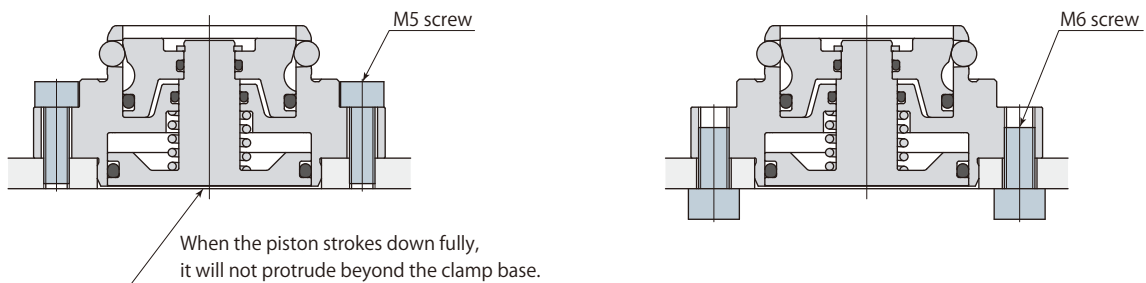

Locate ring

Lower surface mounting

Upper surface mounting

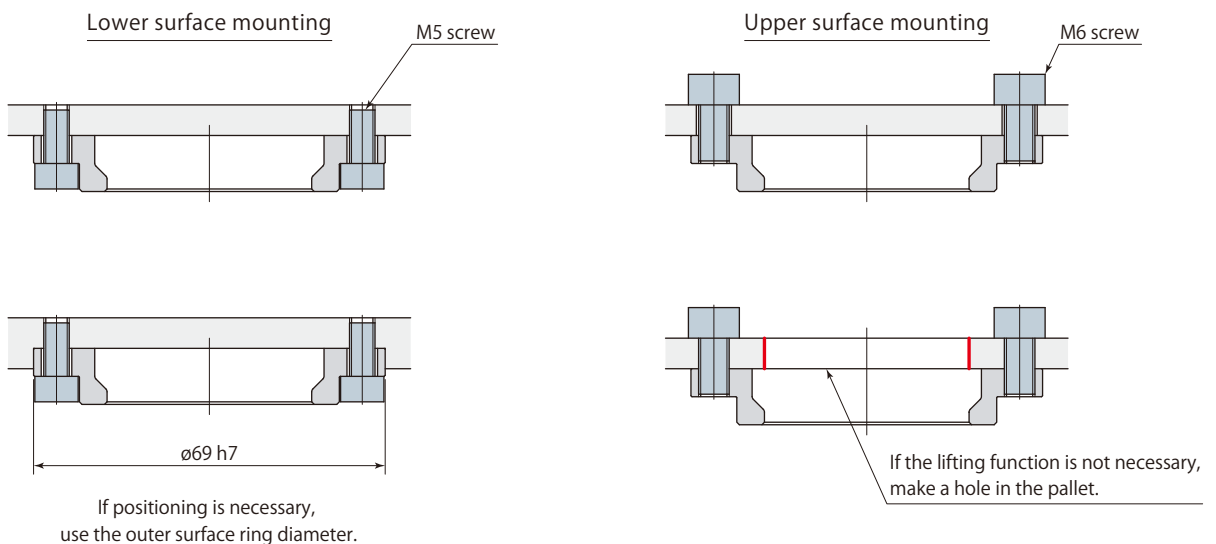

Composition

- Determine the quantity of clamps according to the required amount of force.

1 pc

- If you need to determine the phase rotation direction, use a pin.

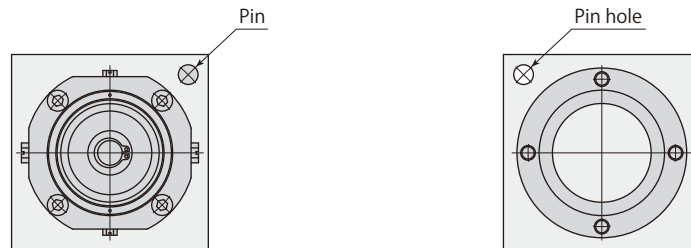

2 pcs and more

- The clamp can be freely positioned according to the plate specifications.

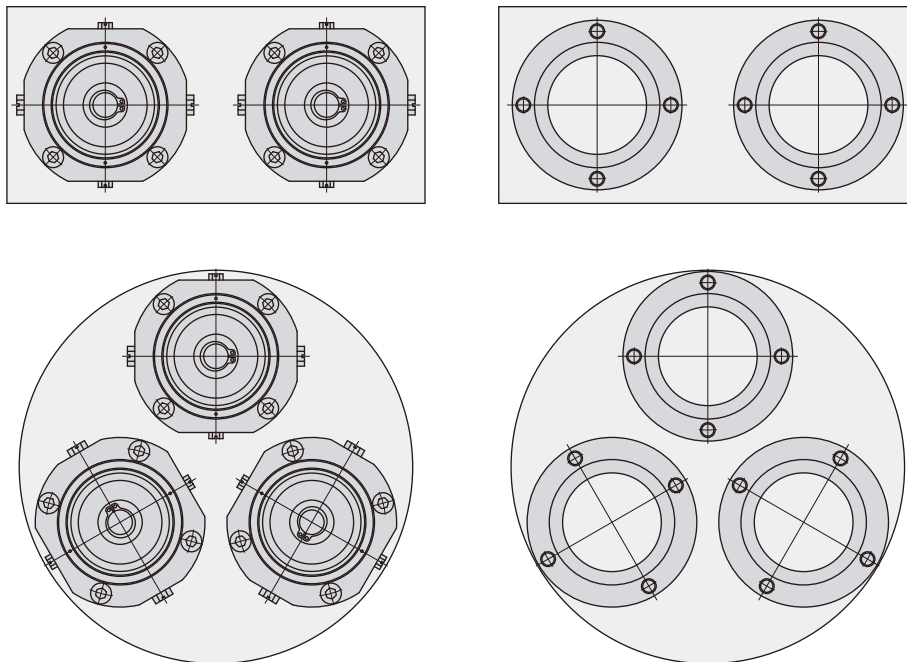

Installation

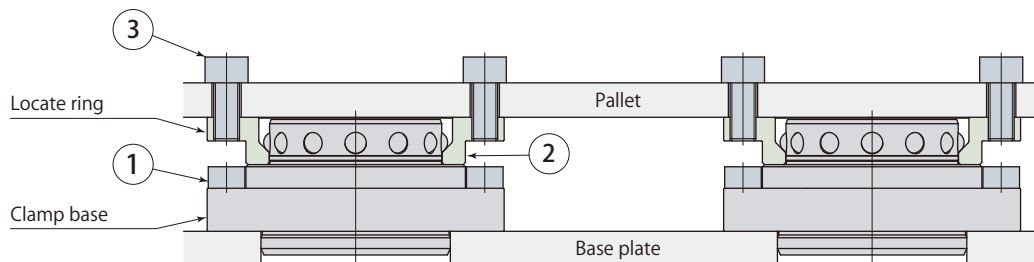

- ① Install the clamp base onto the base plate.
- ② Clamp the locate ring onto the clamp base.
- ③ Fasten the screws of the locate ring for final positioning.

Machining is simple because pitch accuracy between the clamps and the plate is unnecessary.

Dimensions

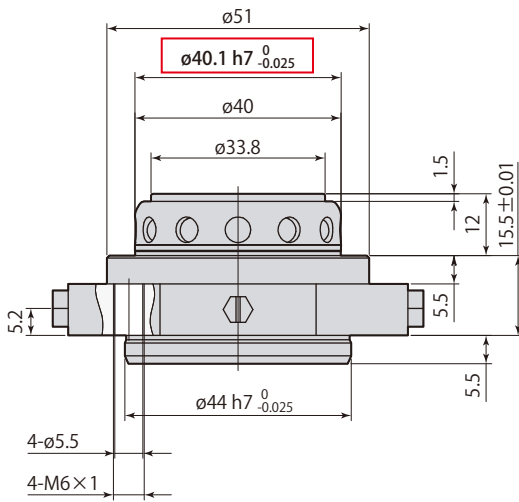
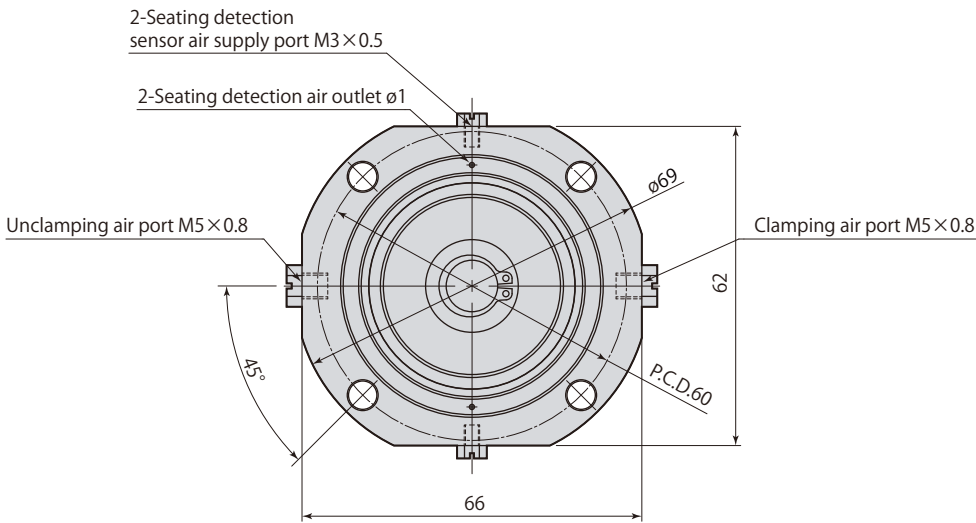

Unclamp

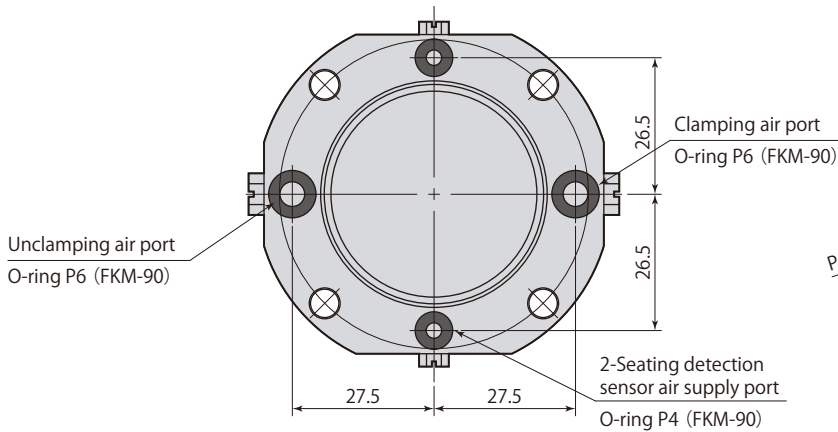
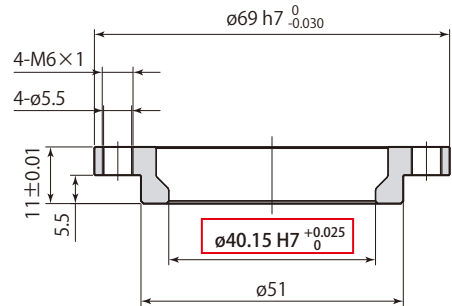

Clamp base

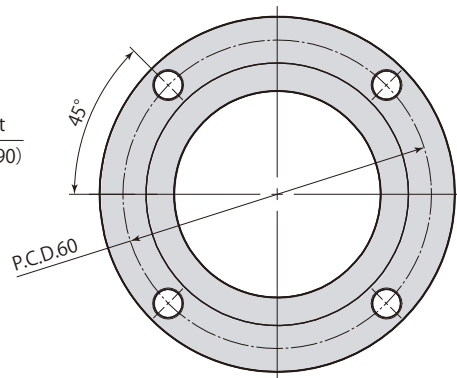

Locate ring

Mounting details

Clamp base

Bolting on the top

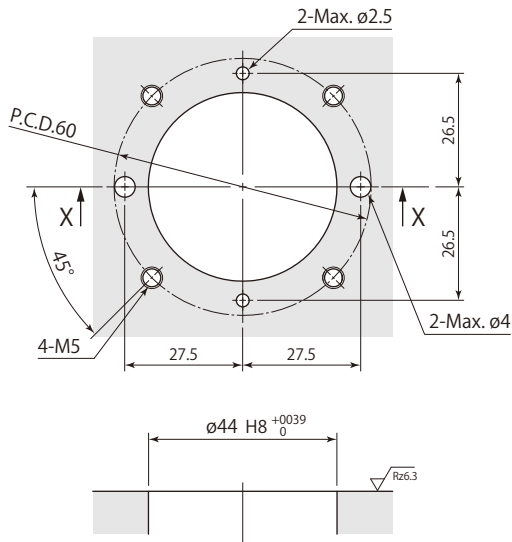

X-X

Locate ring

Bolting from the bottom

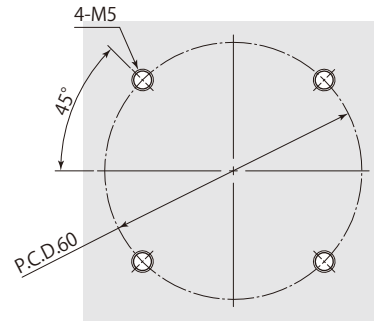

Bolting from the bottom

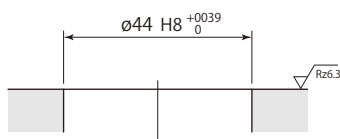

Y-Y

Bolting on the top

When lift is not used

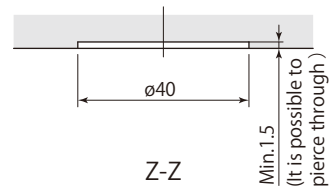

4-M6 pilot hole
($\phi 6.8$)

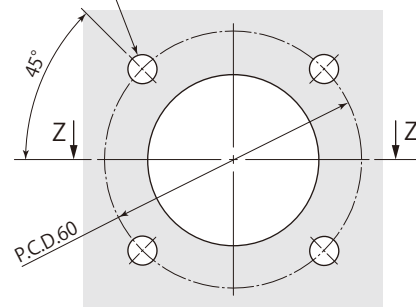

4-M6 pilot hole
($\phi 6.8$)

The clamp is detected by a proximity sensor

- The clamping status can be detected with a multi-setting proximity sensor that detects distance.
 Recommended proximity sensor: Azbil H3C-HC03 Series
 Refer to the sensor supplier's instruction manual for the details of setting.

Unclamping status

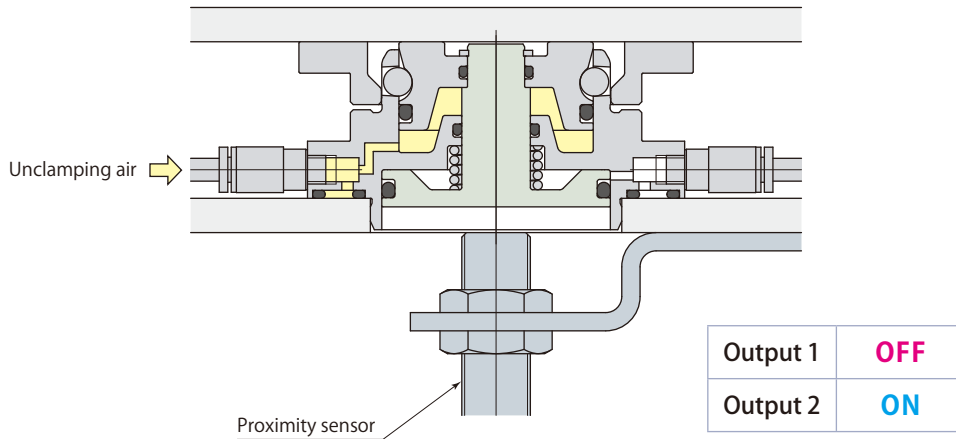

Clamping status

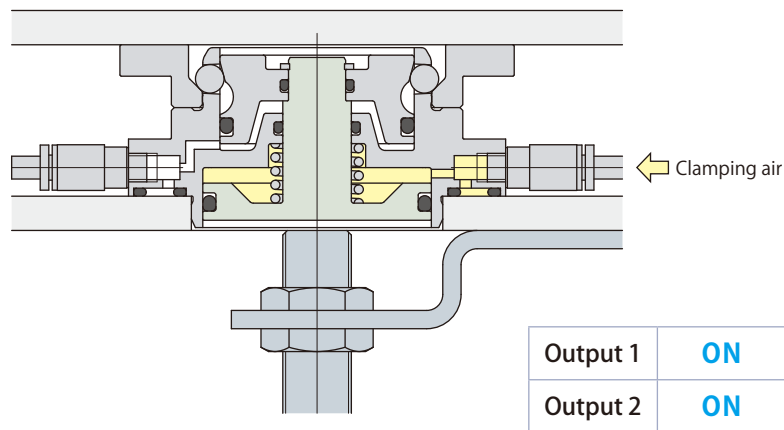

Piston stroke-end position

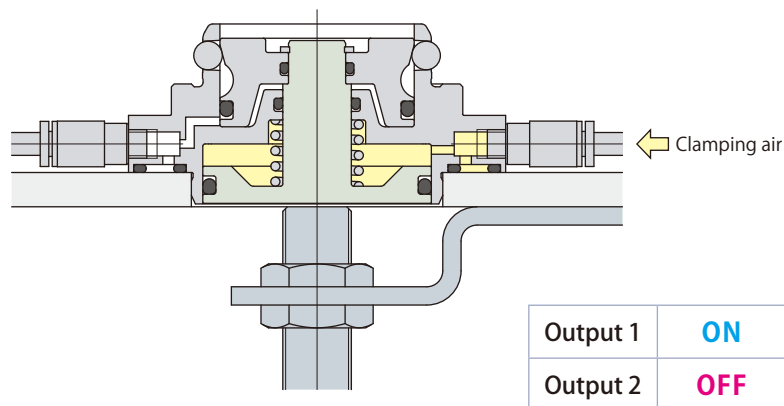

- The sensor must be installed so as not to come into contact with the piston.

Decoupling according to the clamp stroke

- Coupling/Decoupling can be done by the stroke of the pallet clamp. For the coupler, refer to the general catalog (CLS-35E).

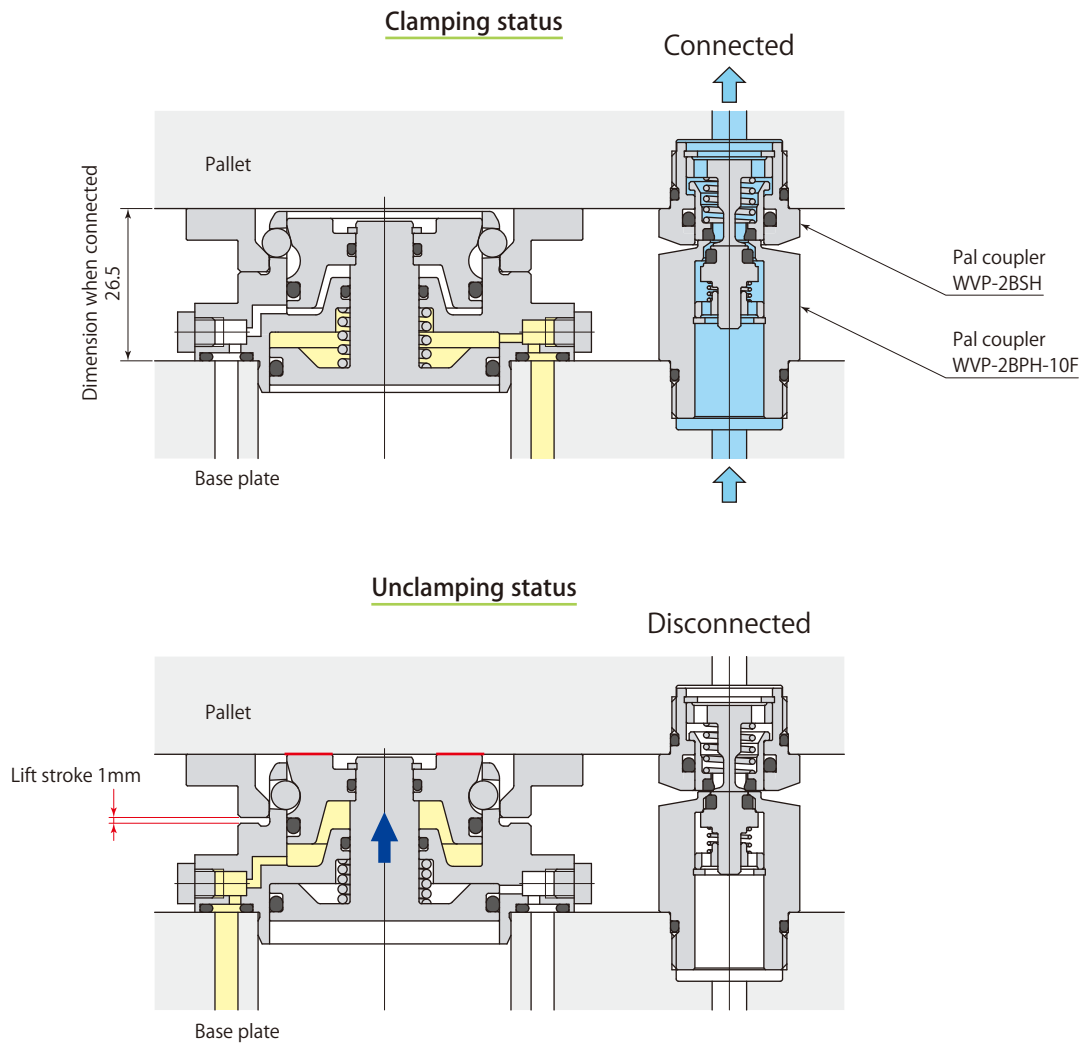

Unclamping by an external mechanism

- Sample diagram as shown below demonstrates how to unclamp by using an external mechanism to press the lower part of the piston.

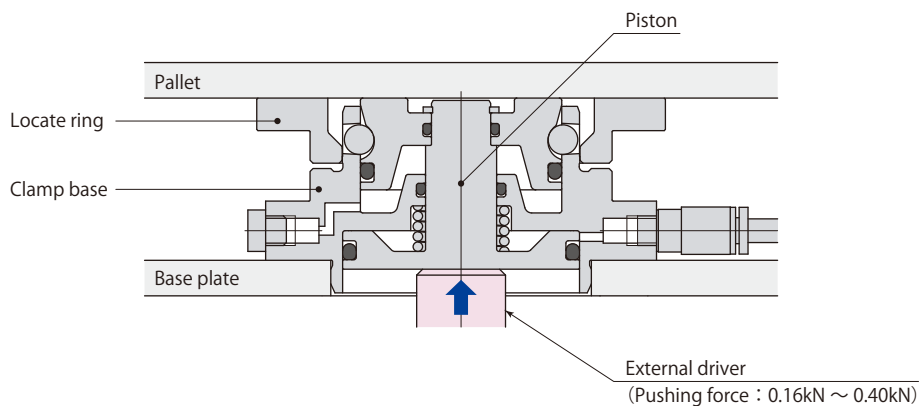

Pascal

Itami, Hyogo, Japan 664-8502
TEL. 072-777-3333 FAX. 072-777-3520



CERTIFICATE OF APPROVAL ISO9001