

Pascal control system

Pascal control system



Solenoid valve unit GSH

Pascal pump

model

X63



New series of Pascal pump model X63 which pursues more reliability.

Air-driven, Compact, High performance hydraulic pump

High cycle, reliable reciprocation of air and hydraulic piston ensures a repetitive suction and discharge oil process. As discharge pressure hikes up to the circuit set pressure, reciprocation goes slow eventually. Pascal pump stops at the time the discharge pressure reaches the set pressure then keeps balancing air and oil discharge pressure.

At the balanced condition, Pascal pump never consumes air and there is no power loss or oil temperature rise unlike an ordinary electric motor pump.

In the event of pressure drop (oil leakage) in the circuit, the pump immediately reacts to start pumping for recovering the pressure loss. When leaking oil, the pump restarts pumping and the sound of pumping is like an alarm for leakage to call operator for servicing.

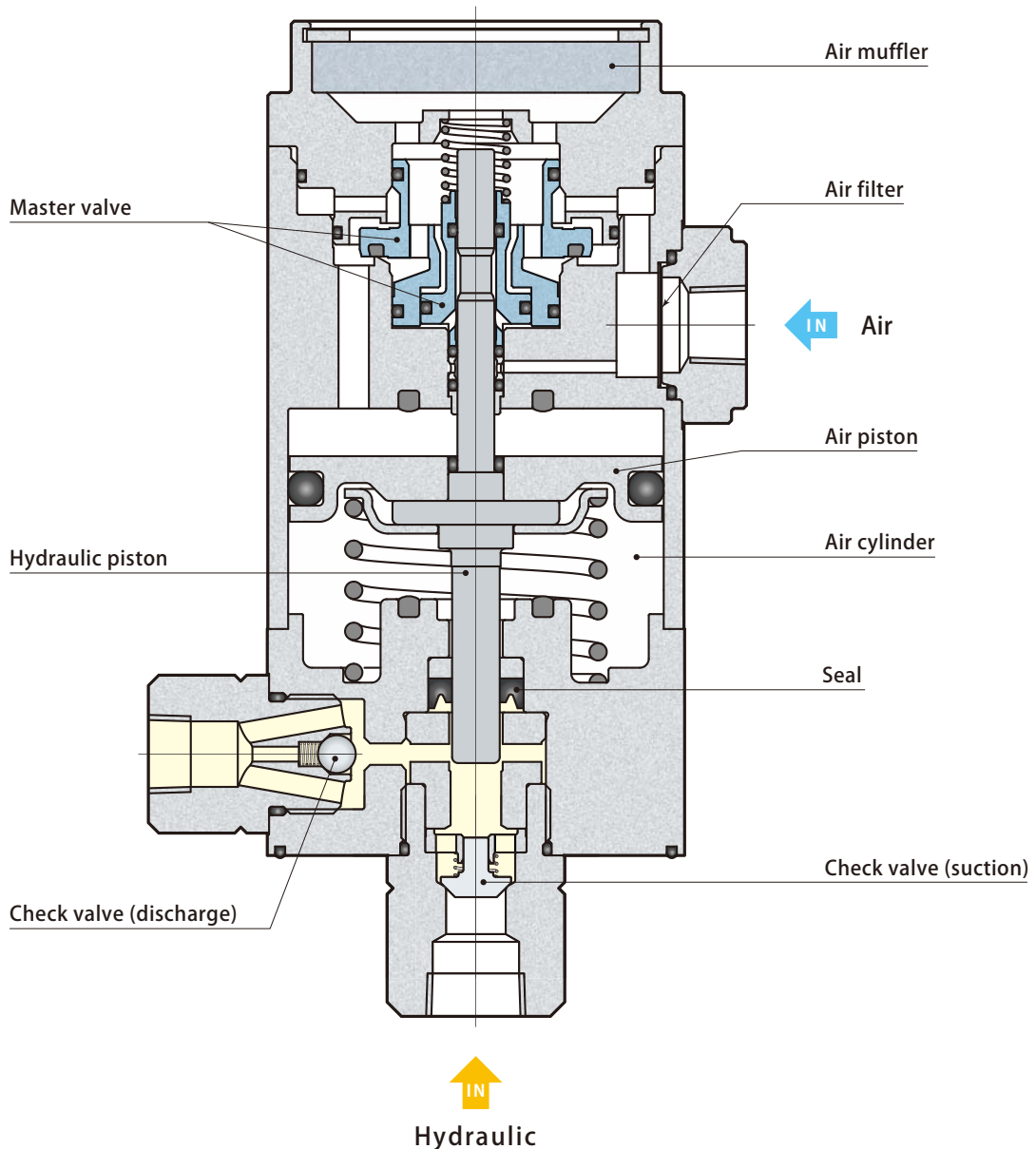

Pascal control unit

model

HCS

Solenoid valve unit GSH

Returning oil to the tank at air bleeding

Adopting transparent pipe to return the oil from air bleeding valve to the tank, air bleeding can be done without draining the oil.

Visible oil level gauge with red ball

It can be installed from the rear and lower side.

Adoption of steel tank which is strong against impact and heat

Pascal control unit

HCSA-H2DDF

416171

Pascal corp.

Pressure Switch SAA210P-F Set point: Inc. 14.7 MPa MADE IN JAPAN

Pressure Switch SAA210PF Set point: Inc. 14.7 MPa MADE IN JAPAN

Pressure Switch SAA40EF Set point: Inc. 14.7 MPa MADE IN JAPAN

Equipped with filter regulator as standard

Only one piping from the pump to the valve for easier servicing of the pump.

The pipe can be installed or removed easily when exchanging the pump and valve.

The check valve inside the oil tank.

The valve can block the oil flow out of the tank even if the valve unit is demounted when servicing.

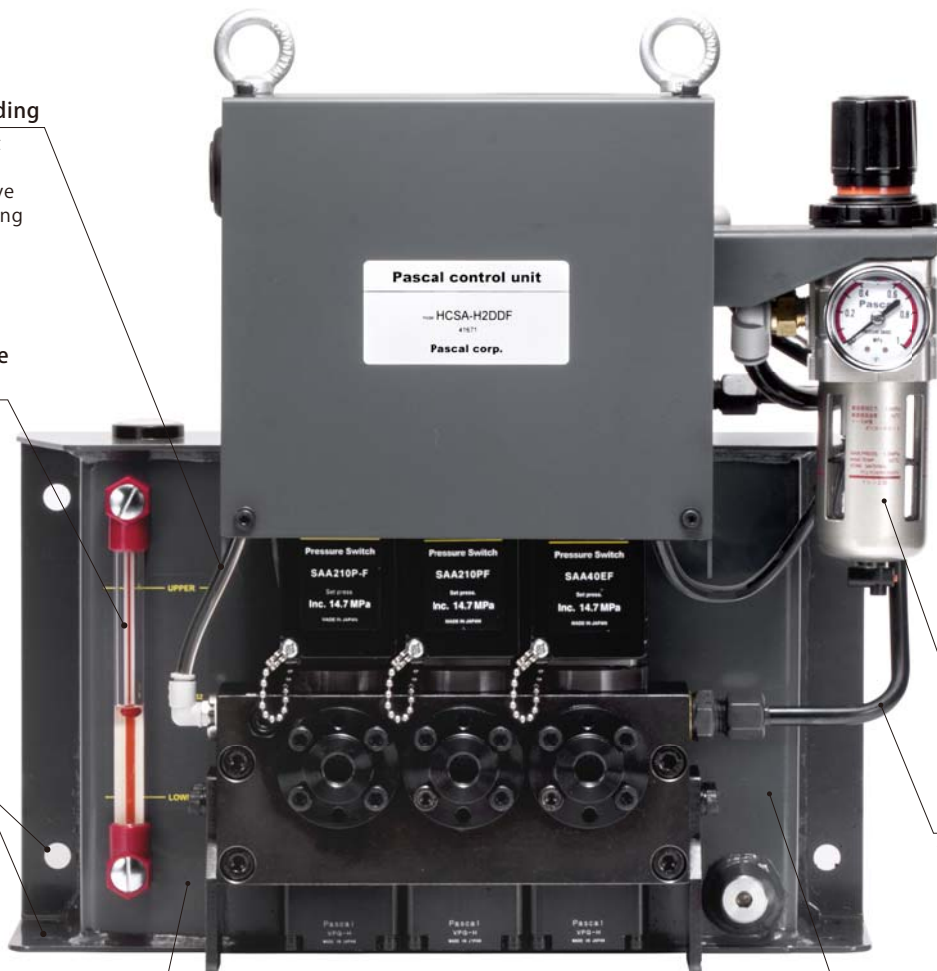

**New Control Unit model HCS
which enables a quick maintenance.**

An electric control type of hydraulic unit suitable for small and medium press machine, consisting of Pascal pump, non leak valve unit and air solenoid valve.

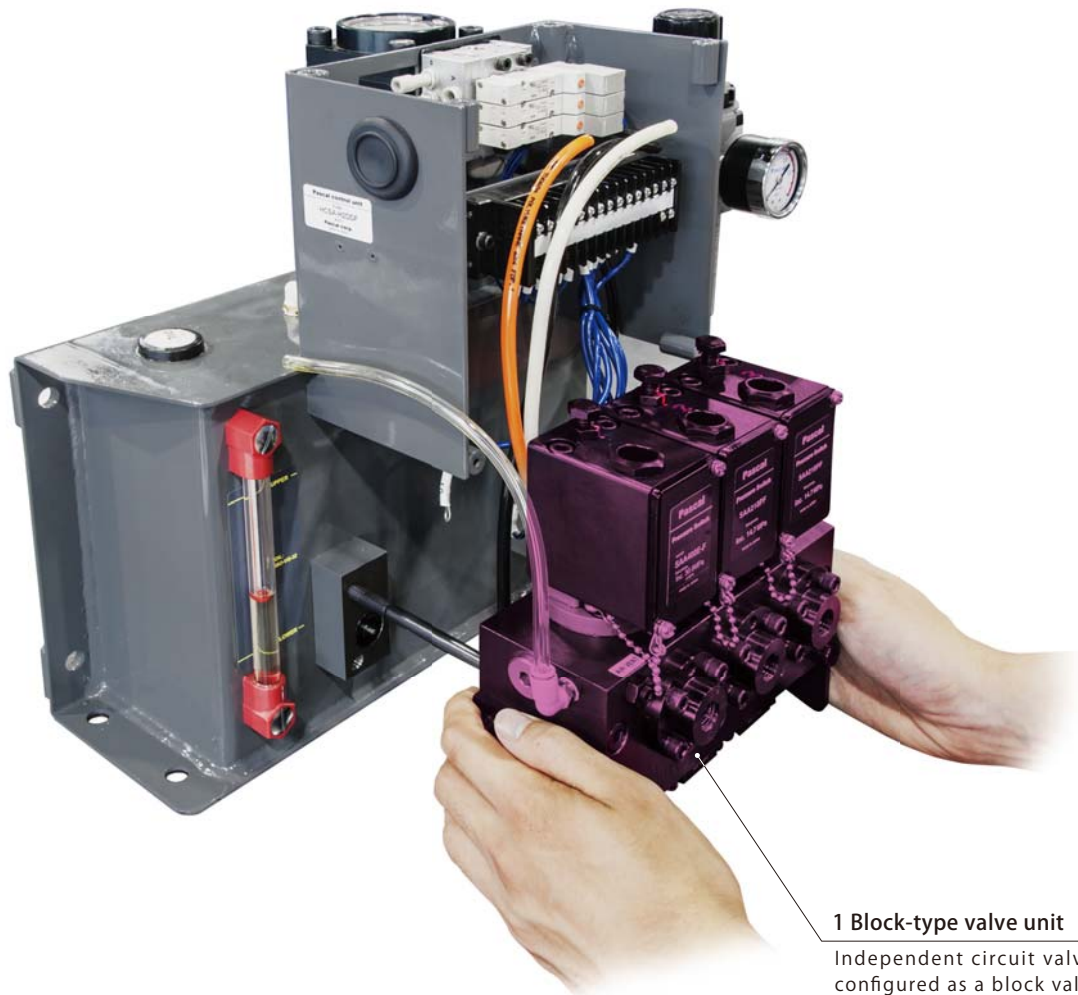

1 Block-type valve unit

Independent circuit valves have been configured as a block valve, improving maintainability.



Model designation

HCS **A** - H2 **D D F** - **U**

- 1 Control voltage
 - 2 Hydraulic circuits •
 - 3 Oil pressure gauge for each circuit •
- * Indicated in 1-4 alphabets

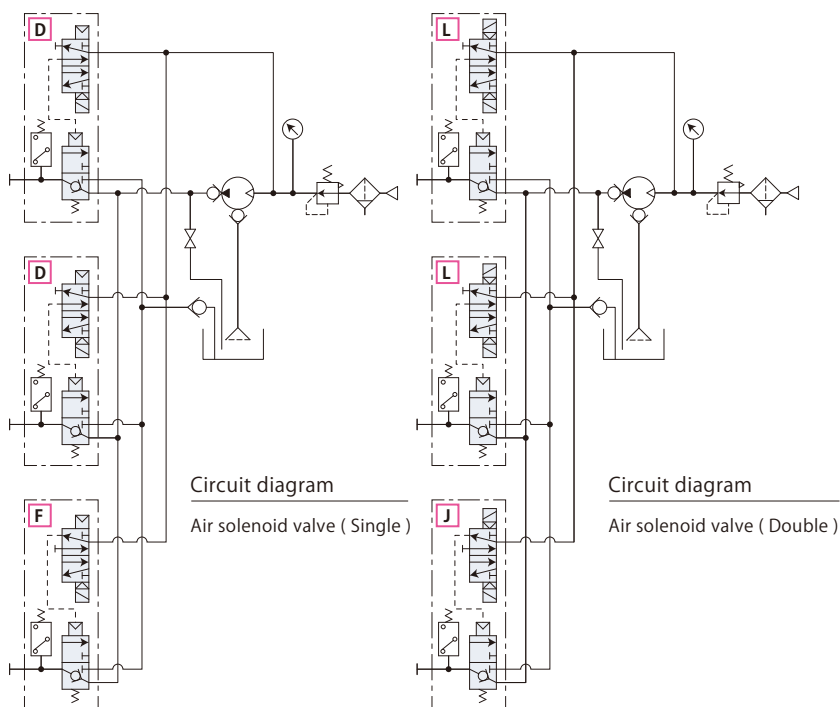

1 Control voltage

A	B	C	D	E
AC100V	AC200V	AC110V	DC24V	AC220V

2 Hydraulic circuits

Number of hydraulic circuits			Hydraulic circuits	
Upper clamp	Lower clamp	Die-lifter	Air solenoid valve (Single)	Air solenoid valve (Double)
	1	—	D	L
1	1	—	DD	LL
2	1	—	DDD	LLL
2	2	—	DDDD	LLLL
1	1	1	DDF	LLJ
2	1	1	DDDF	LLLJ

Clamp circuit Air solenoid valve (Single) : D Air solenoid valve (Double) : L
 Die-lifter circuit Air solenoid valve (Single) : F Air solenoid valve (Double) : J

3 Oil pressure gauge for each circuit

- / : Without
- U : With

Specifications

Model	HCS□-H2□-□		
Number of pumps	1		
Valve switching system	Air pilot system		
Discharge pressure	MPa	24.5	
Driving air pressure	MPa	0.47	
Discharge volume (at no load)	L/min	1.3	
Oil tank capacity	L	HIGH-LEVEL : 3.5	LOW-LEVEL : 1.5
Set pressure of pressure switch	MPa	Clamp circuit : 14.7 (INC.)	Die-lifter circuit : 1.96 (DEC.)
Orifice diameter	mm ²	Discharge : 12.5	Return : 28.1
Air consumption rate	Nm ³ /min	Max. 0.4	

- Fluid used : General mineral based hydraulic oil (ISO-VG32 equivalent)
- Operating temperature : 0 ~ 50°C (No frozen)

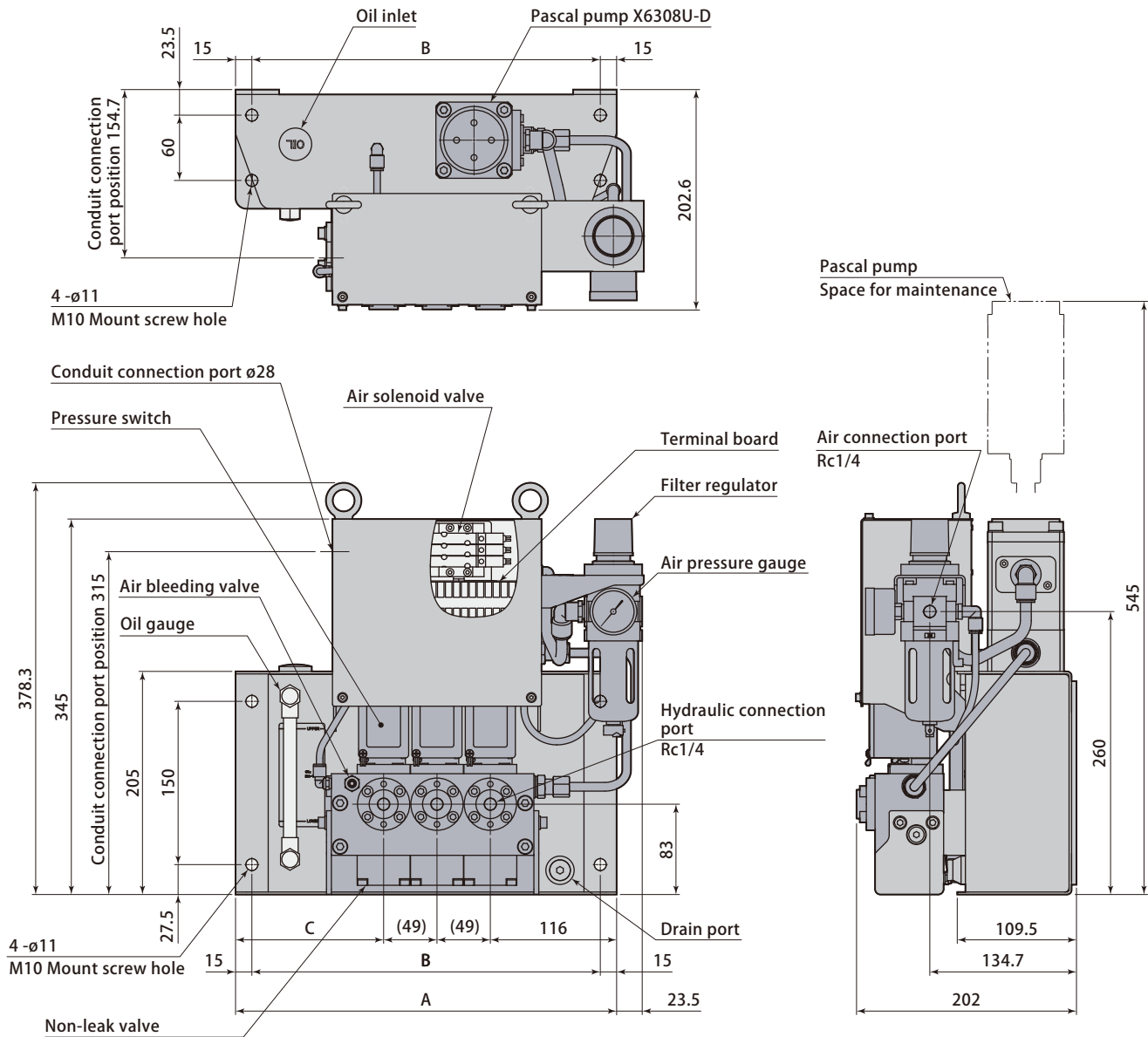

Number of hydraulic circuits		1	2	3	4
A	mm	350	350	350	400
B	mm	320	320	320	370
C	mm	234	185	136	137
Weight	kg	17	20	22	25

Anti-vibration rubber(Option 4 pieces)

model ZPS-B5

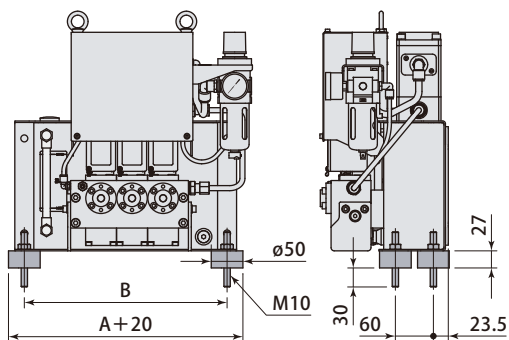

Stand (Option)

model ZPS-S0

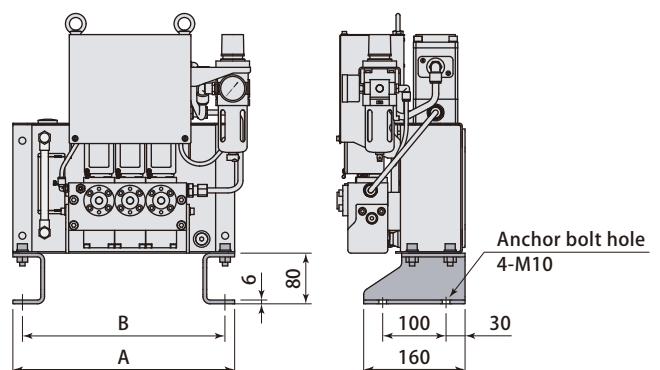



Model designation

HCP **A** - **H2** **D D F** - **U**

- 1 Control voltage
- 2 Pump quantity
- 3 Hydraulic circuits
* Indicated in 1-4 alphabets
- 4 Special specifications

1 Control voltage

A	B	C	D	E
AC100V	AC200V	AC110V	DC24V	AC220V

2 Pump quantity **H2** : 1unit **H22** : 2units

3 Hydraulic circuits

Number of hydraulic circuits			Hydraulic circuits	
Upper clamp	Lower clamp	Die-lifter	Air solenoid valve (Single)	Air solenoid valve (Double)
	1	—	D	L
1	1	—	DD	LL
2	1	—	DDD	LLL
2	2	—	DDDD	LLLL
1	1	1	DDF	LLJ
2	1	1	DDDF	LLLJ

Clamp circuit Air solenoid valve (Single) : D Air solenoid valve (Double) : L
Die-lifter circuit Air solenoid valve (Single) : F Air solenoid valve (Double) : J

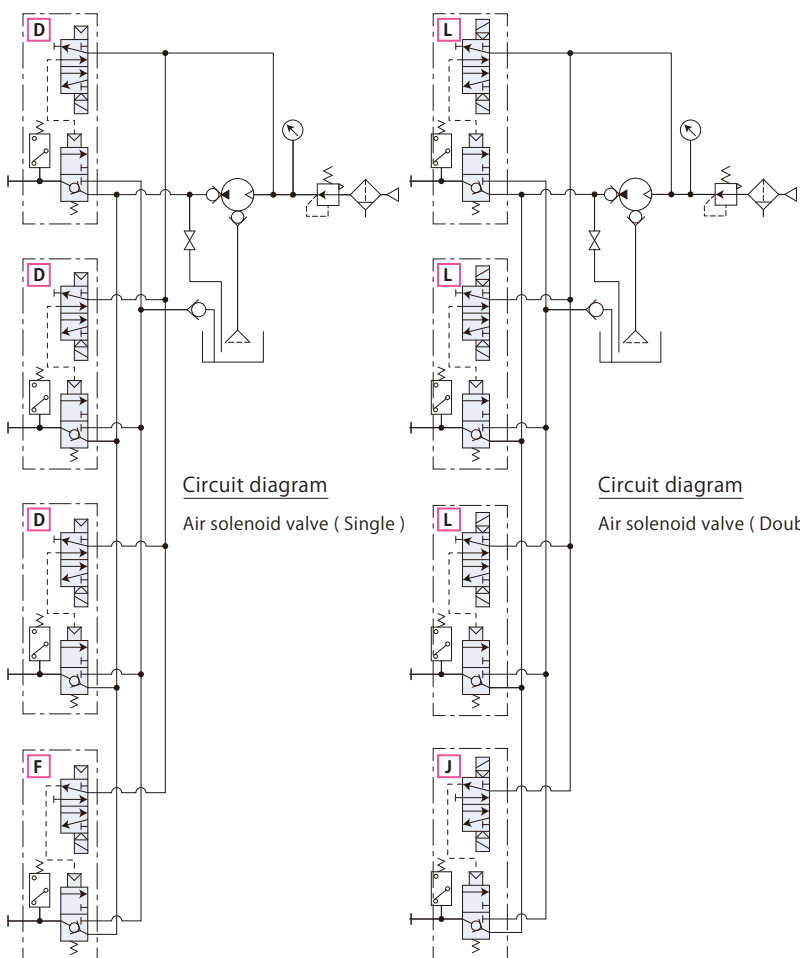

4 Special specifications

- ∕** : Without
- L** : Low oil level detection switch
- T2** : For auto slider 2-position double air solenoid valve equipped
- T3** : For auto slider 3-position center exhaust air solenoid valve equipped
- U** : Oil pressure gauge for each circuit

Specifications

Model	HCP□-H2□-□		HCP□-H22□-□	
	1		2	
Number of pumps	1		2	
Valve switching system	Air pilot system			
Discharge pressure	MPa	24.5		
Driving air pressure	MPa	0.47		
Maximum working pressure	MPa	30.8		
Discharge volume (at no load)	L/min	1.3	2.6	
Oil tank capacity	L	HIGH-LEVEL : 5.4	∕	LOW-LEVEL : 2.2
Set pressure of pressure switch	MPa	Clamp circuit : 14.7 (INC.)	∕	Die-lifter circuit : 1.96 (DEC.)
Orifice diameter	mm ²	Discharge : 12.5	∕	Return : 28.1
Air consumption rate	Nm ³ /min	Max. 0.4		Max. 0.8

- Fluid used : General mineral based hydraulic oil (ISO-VG32 equivalent)
- Operating temperature : 0 ~ 50°C (No frozen)
- Standard working pressure : 24.5MPa
- For 5 or more circuits application, contact Pascal for the details.

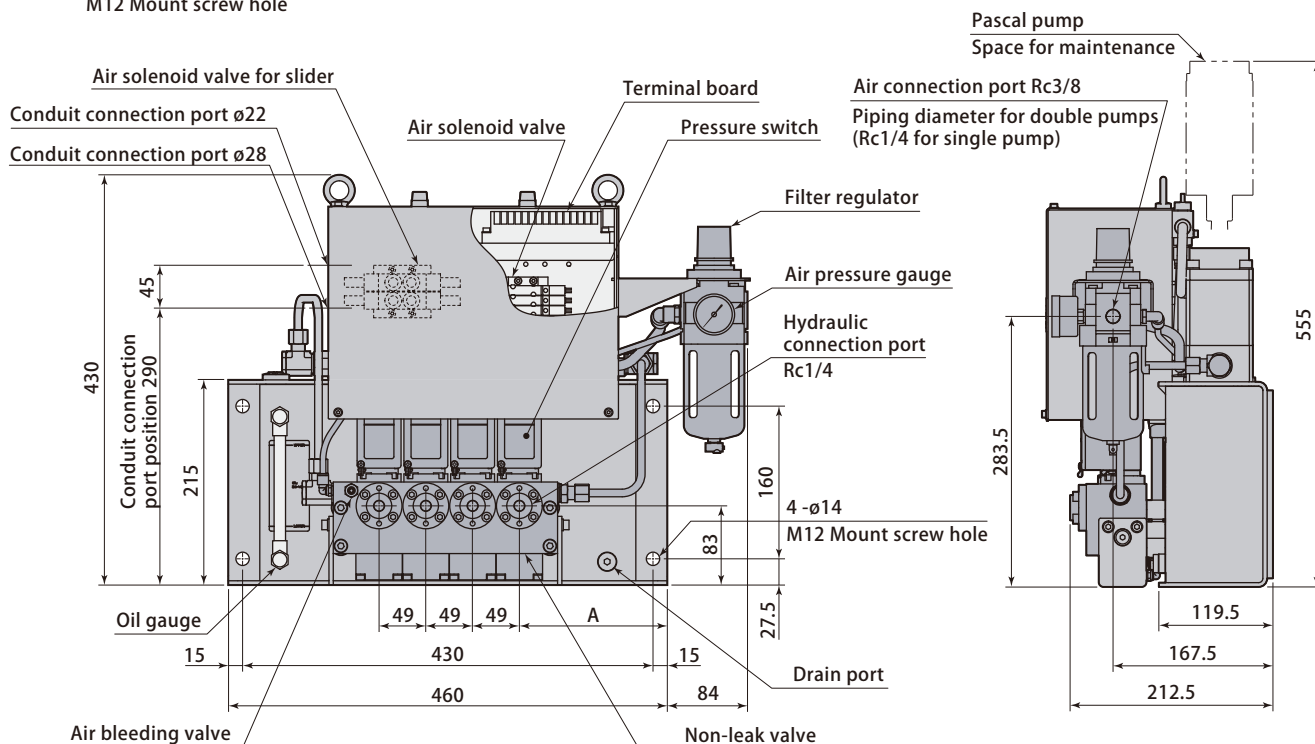
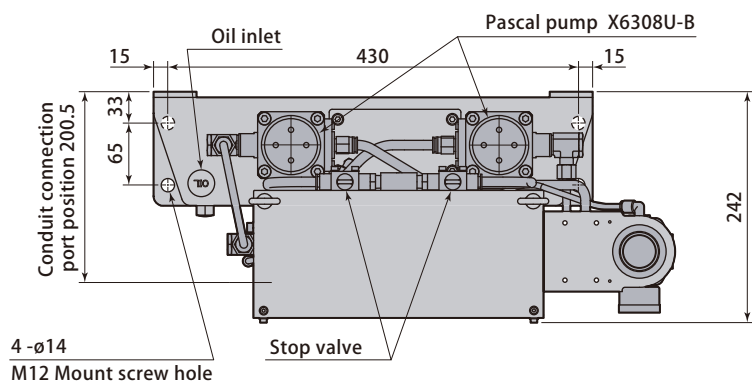

Number of hydraulic circuits	1	2	3	4
A mm	204	179.5	155	155
Weight kg	28	30	32	35

● For the case of double pumps. 3kg to be decreased in case of single pump.

Anti-vibration rubber(Option 4 pieces)

model ZPS-B6

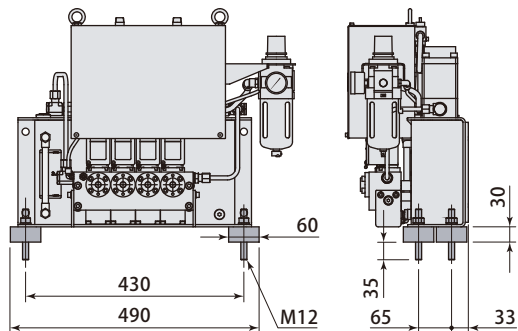

Stand(Option)

model ZPS-S1

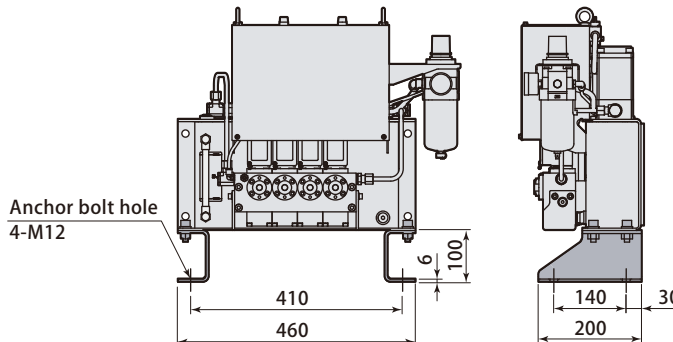



Model designation

VHA - A A C

1 Hydraulic circuits ●.....
* Indicated in 1-3 alphabets

1 Hydraulic circuits

Number of hydraulic circuits			Hydraulic circuits *	Weight kg
Upper clamp	Lower clamp	Die-lifter		
	1	—	A	4.2
—	—	1	B	4.2
1	1	—	AA	6.8
	1	1	C	6.8
2	1	—	AAA	9.0
1	1	1	AC	9.0
2	1	1	AAC	11.1

* C=A+B

Specifications

Model		VHA-□	
Standard working pressure	MPa	24.5	
Maximum working pressure	MPa	30.8	
Set pressure of pressure switch	Clamp circuit	MPa	14.7 (INC.)
	Die-lifter circuit	MPa	1.96 (DEC.)
Orifice diameter	mm ²	Discharge : 14.2 / Return : 14.2	

- Fluid used : General mineral based hydraulic oil (ISO-VG32 equivalent)
- Operating temperature : 0 ~ 70°C (No frozen)

VHA-A
VHA-B

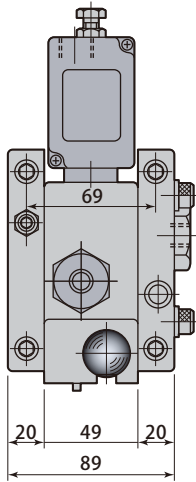

VHA-AA
VHA-C

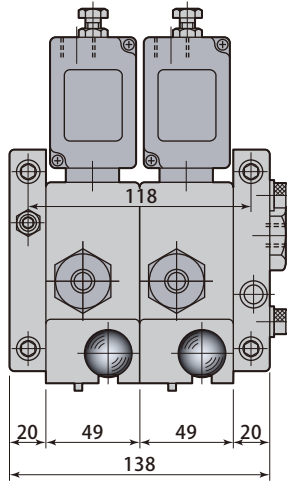

VHA-AAA
VHA-AC

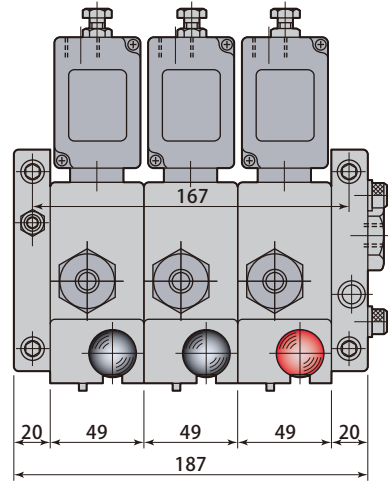

VHA-AAC

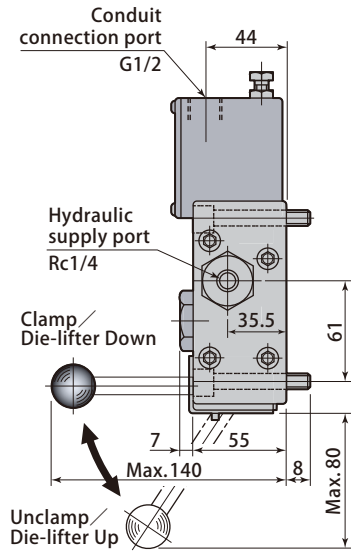
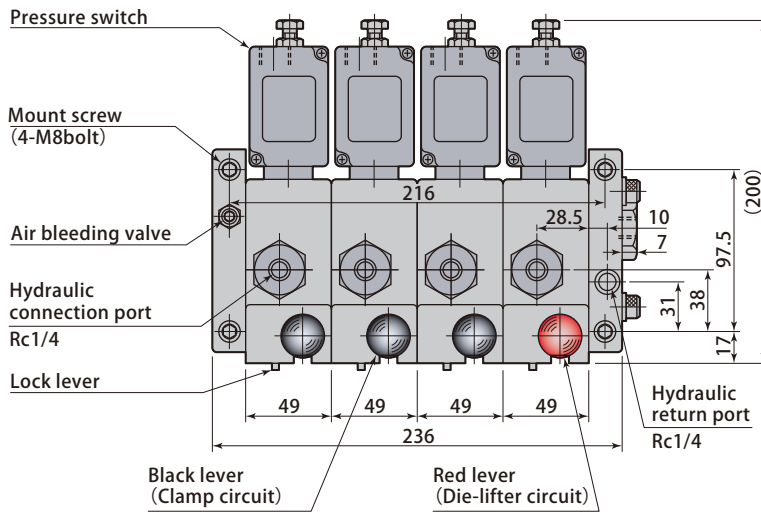

Anti-vibration rubber (Option)
model ZPS-B3-HVSB1420

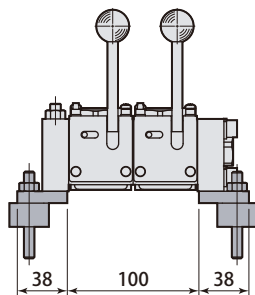
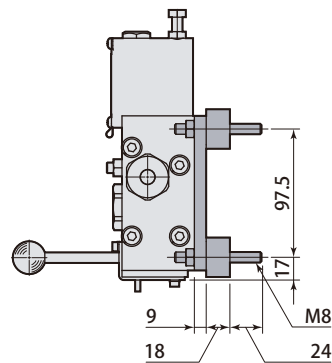
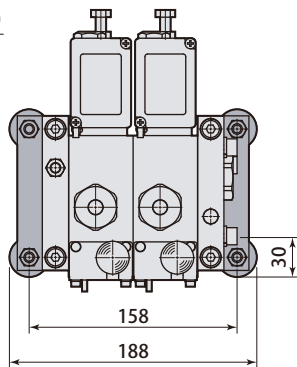



Model designation

HUT – 2

Specifications

Model		HUT-2
Number of pumps		1
Discharge pressure	MPa	24.5
Driving air pressure	MPa	0.47
Discharge volume (at no load)	L/min	1.3
Oil tank capacity	L	HIGH-LEVEL : 1.5 / LOW-LEVEL : 0.6
Air consumption rate	Nm ³ /min	Max. 0.4
Weight (without oil)	kg	8.3

- Fluid used : General mineral based hydraulic oil (ISO-VG32 equivalent)
- Operating temperature : 0 ~ 60°C (No frozen)

Circuit diagram

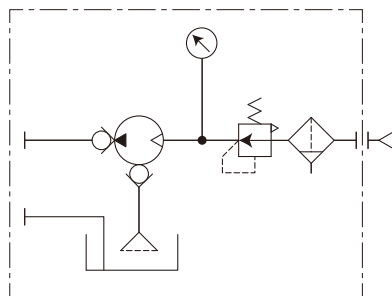

Power unit HUT

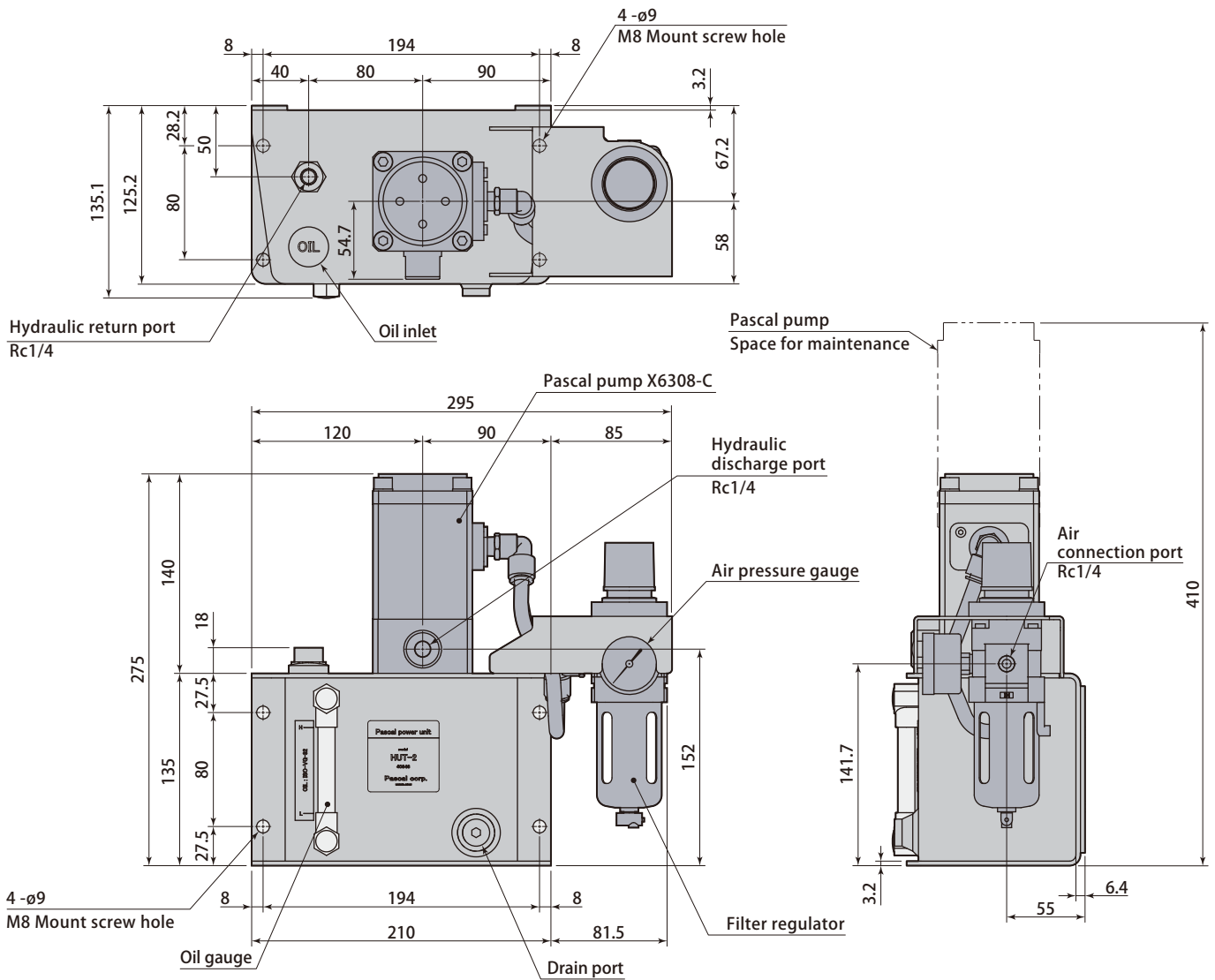

Anti-vibration rubber(Option 4 pieces)
model ZPS-B3

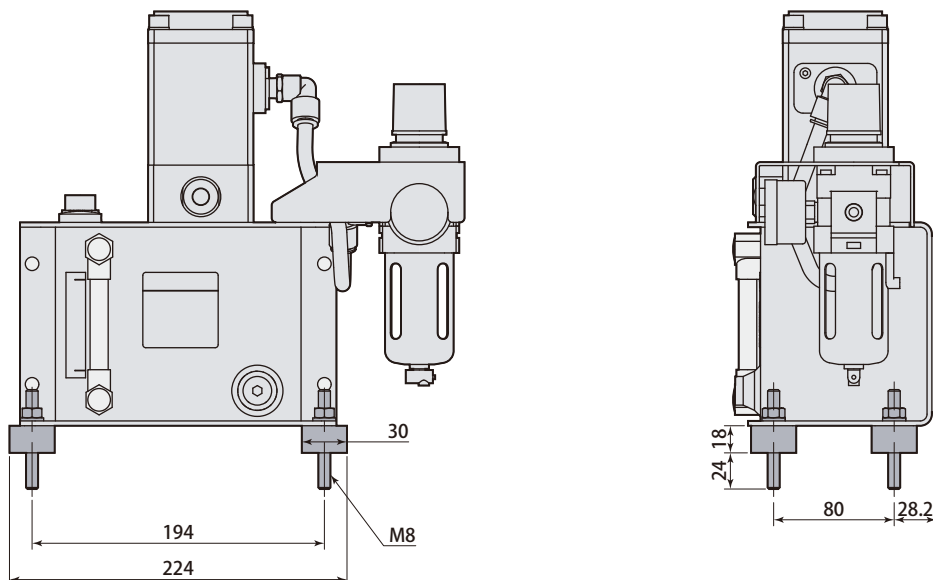



Model designation

VSB **A** - H2 **D D F**

- 1 Control voltage
- 2 Hydraulic circuits
* Indicated in 1-4 alphabets

1 Control voltage

A	B	C	D	E
AC100V	AC200V	AC110V	DC24V	AC220V

2 Hydraulic circuits

Number of hydraulic circuits			Hydraulic circuits	
Upper clamp	Lower clamp	Die-lifter	Air solenoid valve (Single)	Air solenoid valve (Double)
	1	—	D	L
1	1	—	DD	LL
2	1	—	DDD	LLL
2	2	—	DDDD	LLLL
1	1	1	DDF	LLJ
2	1	1	DDDF	LLLJ

Clamp circuit Air solenoid valve (Single) : D Air solenoid valve (Double) : L
 Die-lifter circuit Air solenoid valve (Single) : F Air solenoid valve (Double) : J

Specifications

Model		VSB□-H2□
Standard working pressure	MPa	24.5
Maximum working pressure	MPa	30.8
Supply air pressure	MPa	0.4 ~ 0.7
Set pressure of pressure switch	Clamp circuit	MPa 14.7 (INC.)
	Die-lifter circuit	MPa 1.96 (DEC.)
Orifice diameter	mm ²	Discharge : 12.5 / Return : 28.1

- Fluid used : General mineral based hydraulic oil (ISO-VG32 equivalent)
- Operating temperature : 0 ~ 50°C (No frozen)

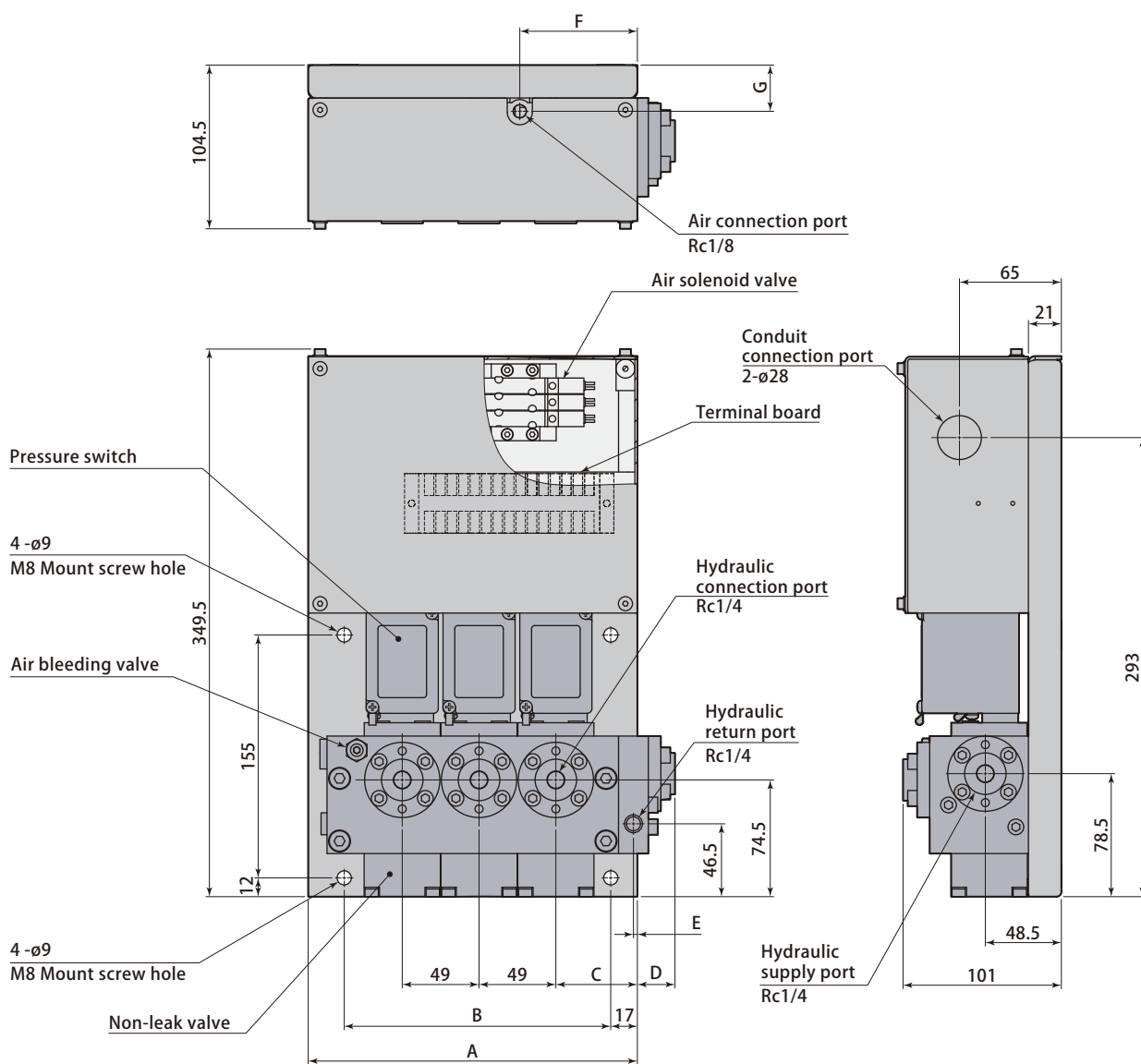

Non-leak valve unit VSB

Number of hydraulic circuits		1	2	3	4
A	mm	115	160	210	260
B	mm	80	120	170	220
C	mm	54	52	52	52
D	mm	22	24	24	24
E	mm	4.5	2.5	2.5	2.5
F	mm	57.5	55	75	75
G	mm	37.5	29.5	29.5	29.5
Weight	kg	8	10	13.5	16

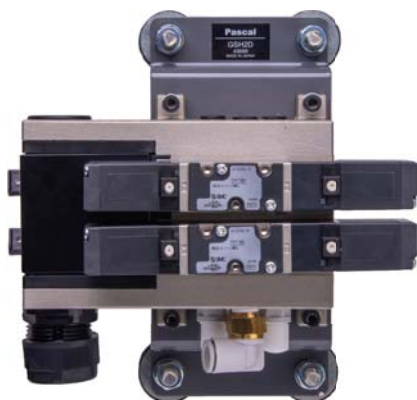

Model designation

Circuit diagram

GSH 1 A

- 1 Number of circuits
- 2 Control voltage

1 Number of circuits

1	2	3
1 circuit	2 circuits	3 circuits

2 Control voltage

A	B	C	D	E
AC100V	AC200V	AC110V	DC24V	AC220V

GSH1

GSH2

GSH3

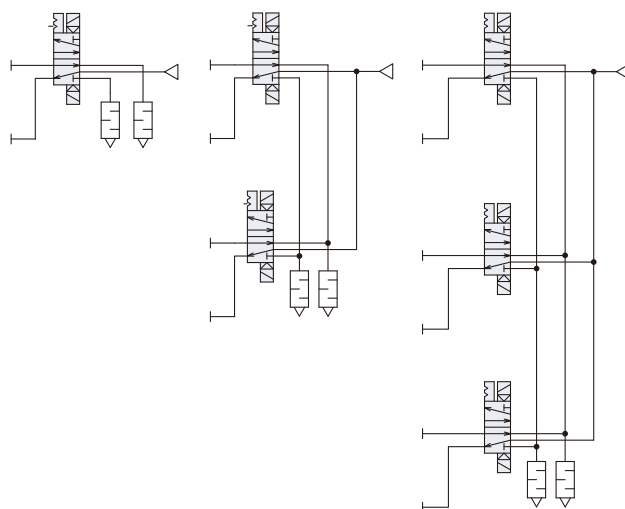

Specifications

Model	GSH1□	GSH2□	GSH3□	
Fluid used	Air			
Type of seal	Metal seal			
Solenoid valve	2 Position Double			
Max. operating pressure	MPa	1.0		
Proof pressure	MPa	1.5		
Fluid temperature range	°C	-10 ~ 60		
Orifice area	mm ²	15		
Mass	kg	2	2.2	2.8
Protection structure	Dust Proof			
Oil supply	Nil			

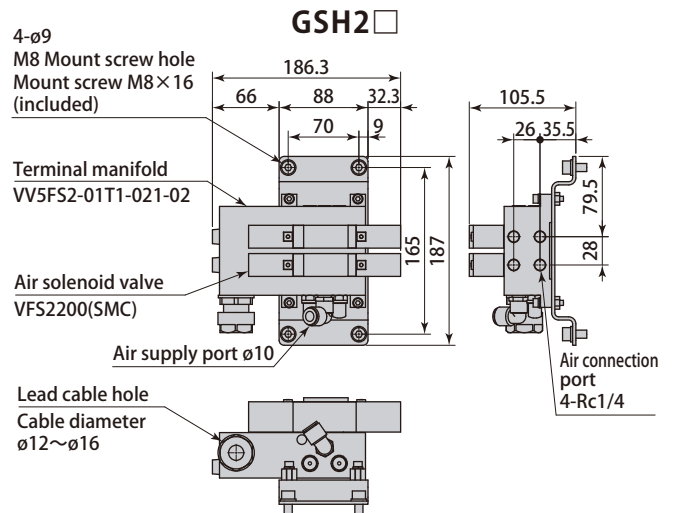
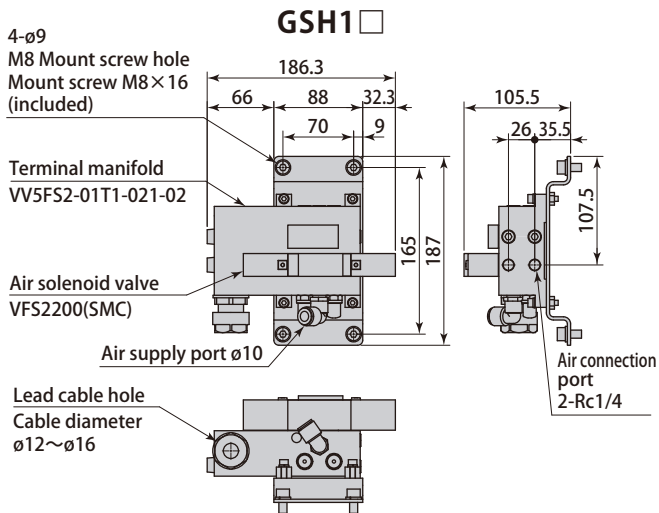

GSH1 □ When mounting anti-vibration rubber

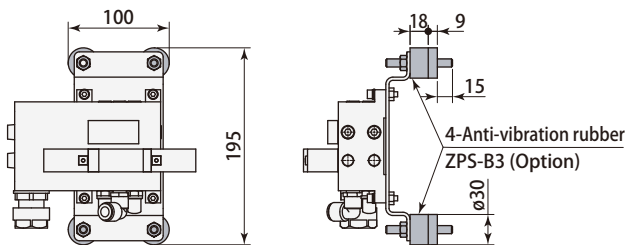

GSH2 □ When mounting anti-vibration rubber

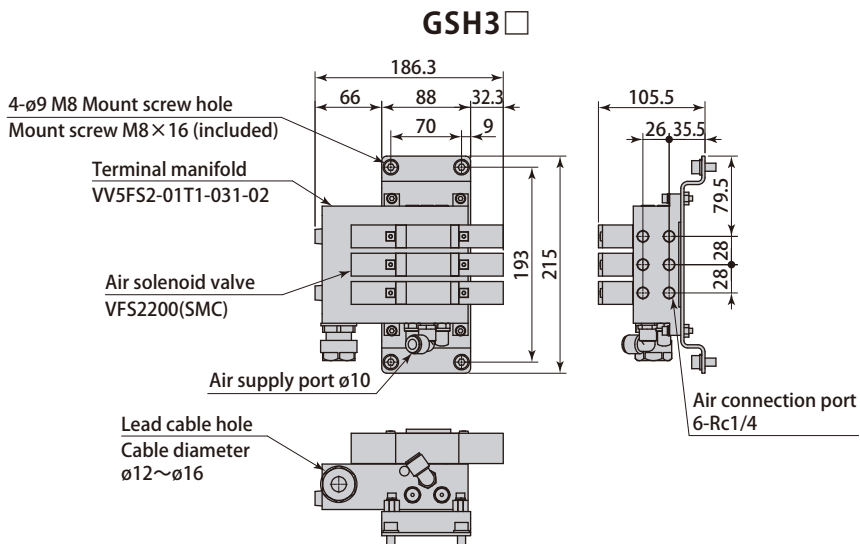
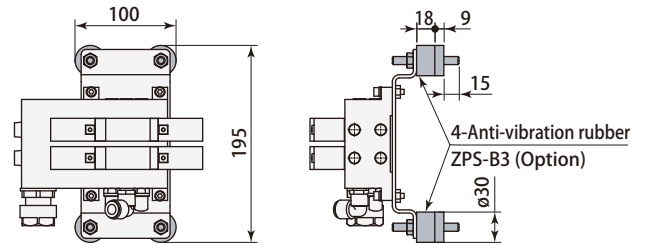

GSH3 □ When mounting anti-vibration rubber

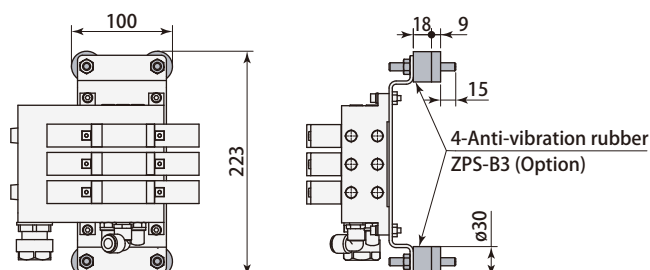

D Circuit

Number of hydraulic circuits		
Upper clamp	Lower clamp	Die-lifter
1		—

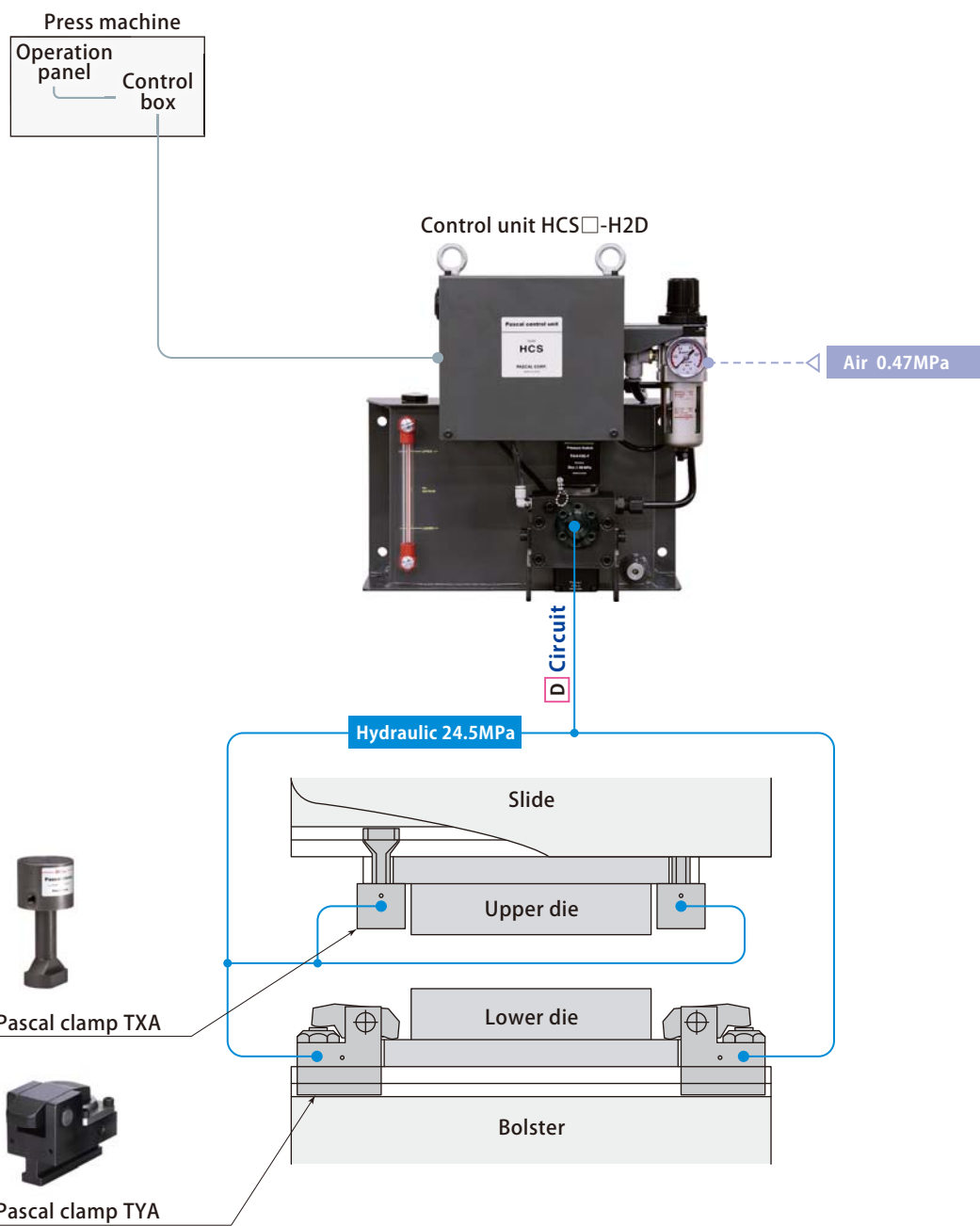

Control system
Example of hydraulic circuit

DD Circuits

Number of hydraulic circuits		
Upper clamp	Lower clamp	Die-lifter
1	1	—

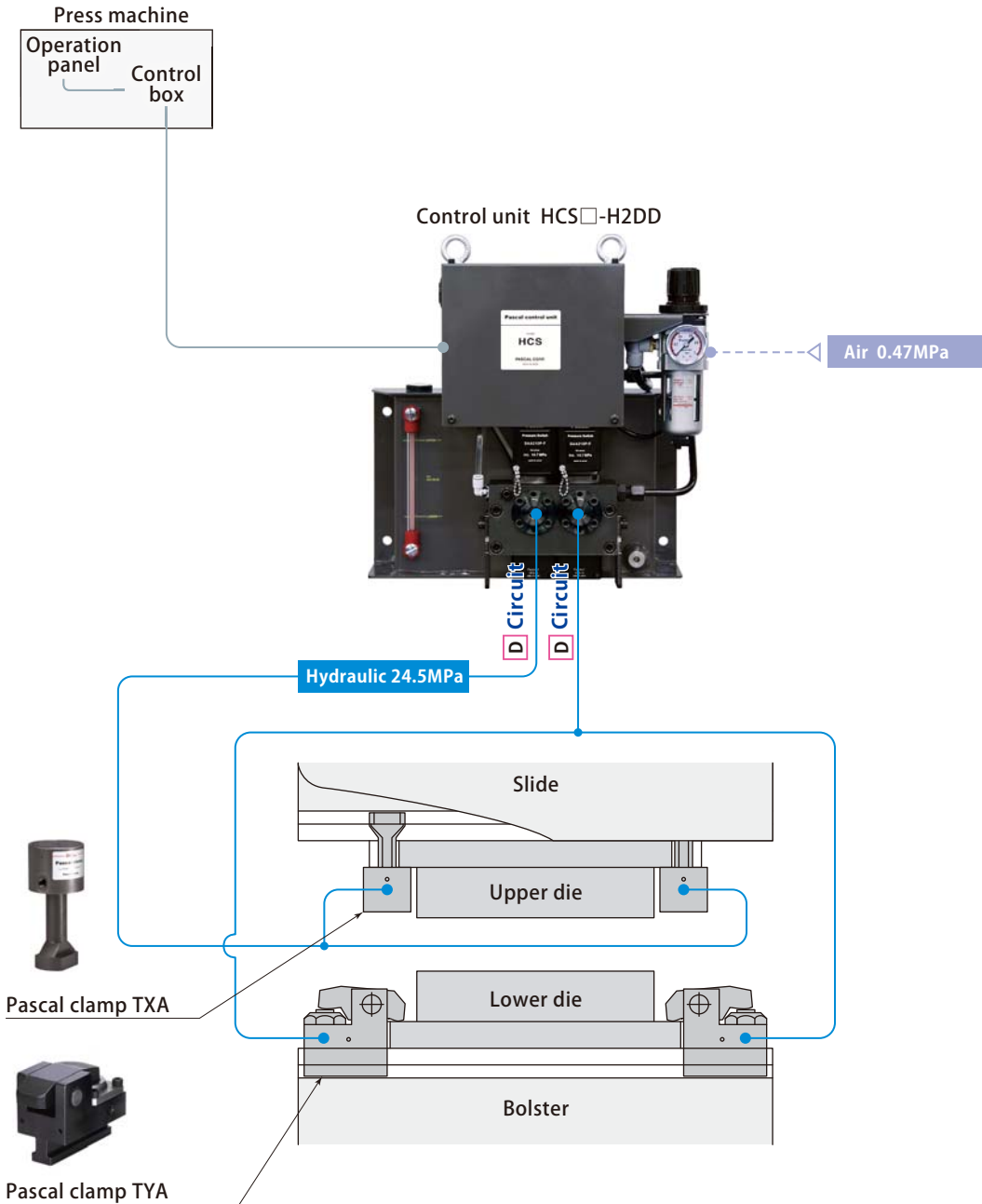

Control system
Example of hydraulic circuit

DDF Circuits

Number of hydraulic circuits		
Upper clamp	Lower clamp	Die-lifter
1	1	1

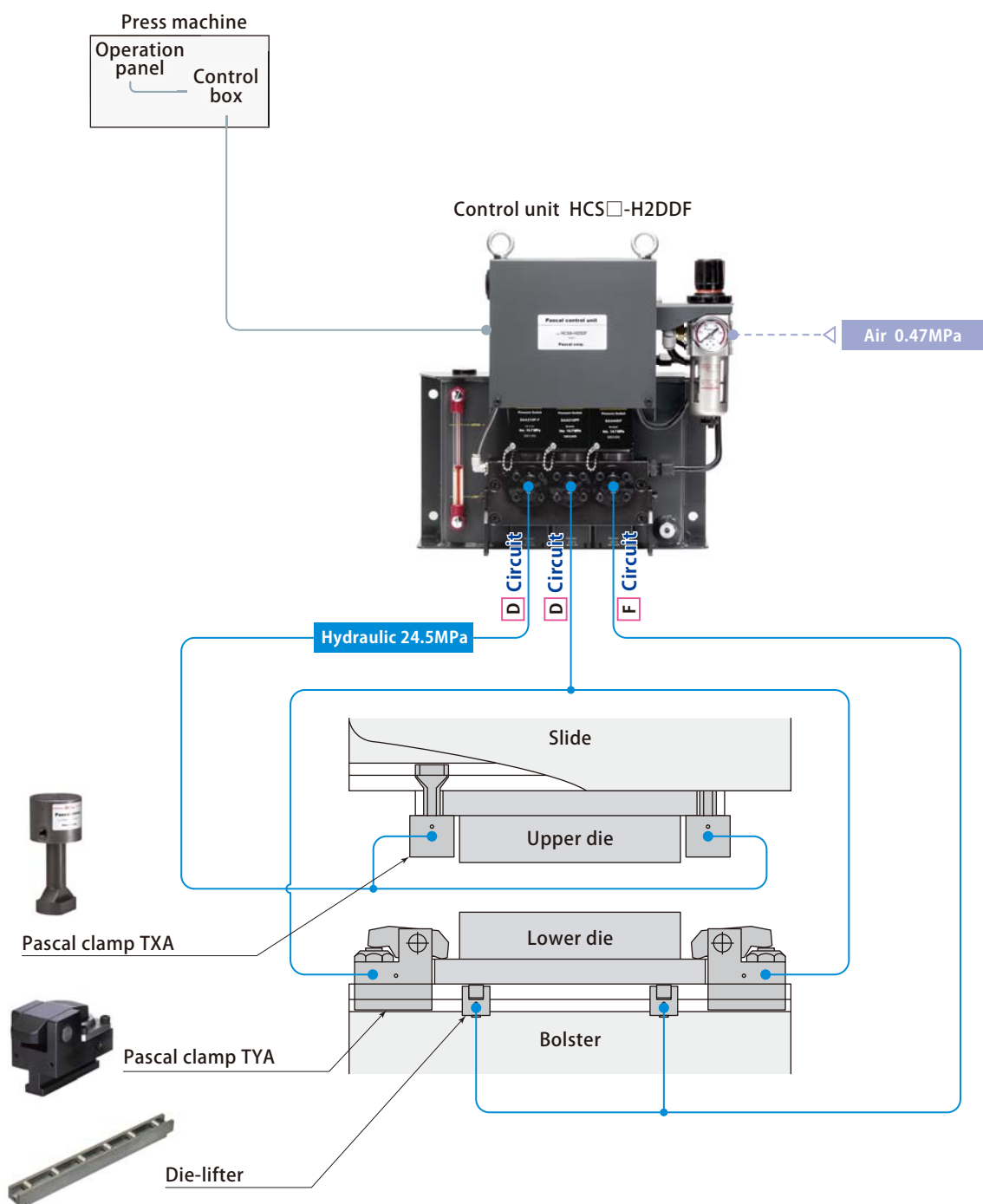

Control system
Example of hydraulic circuit

DDF Circuits

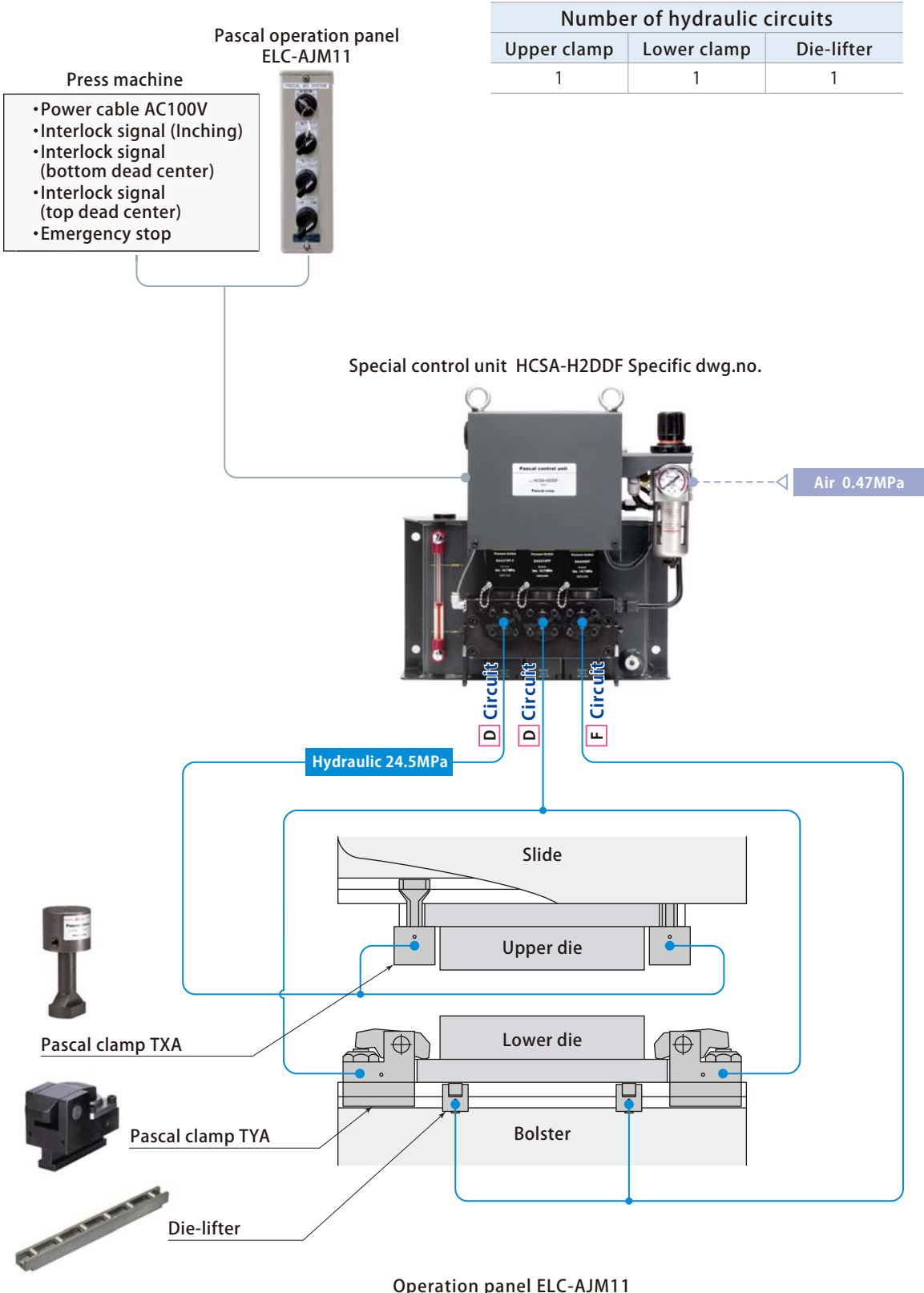

- It is a made-to-order product.
- It is designed for Japan domestic market. (Not complied with overseas standard)
- Model ELC-AJM10, which is applicable for DD circuit of control unit, is also available as an option.
- The control unit need a modification to combine to use with the operation panel. (The terminal block is added.)

A Circuit

Number of hydraulic circuits		
Upper clamp	Lower clamp	Die-lifter
	1	—

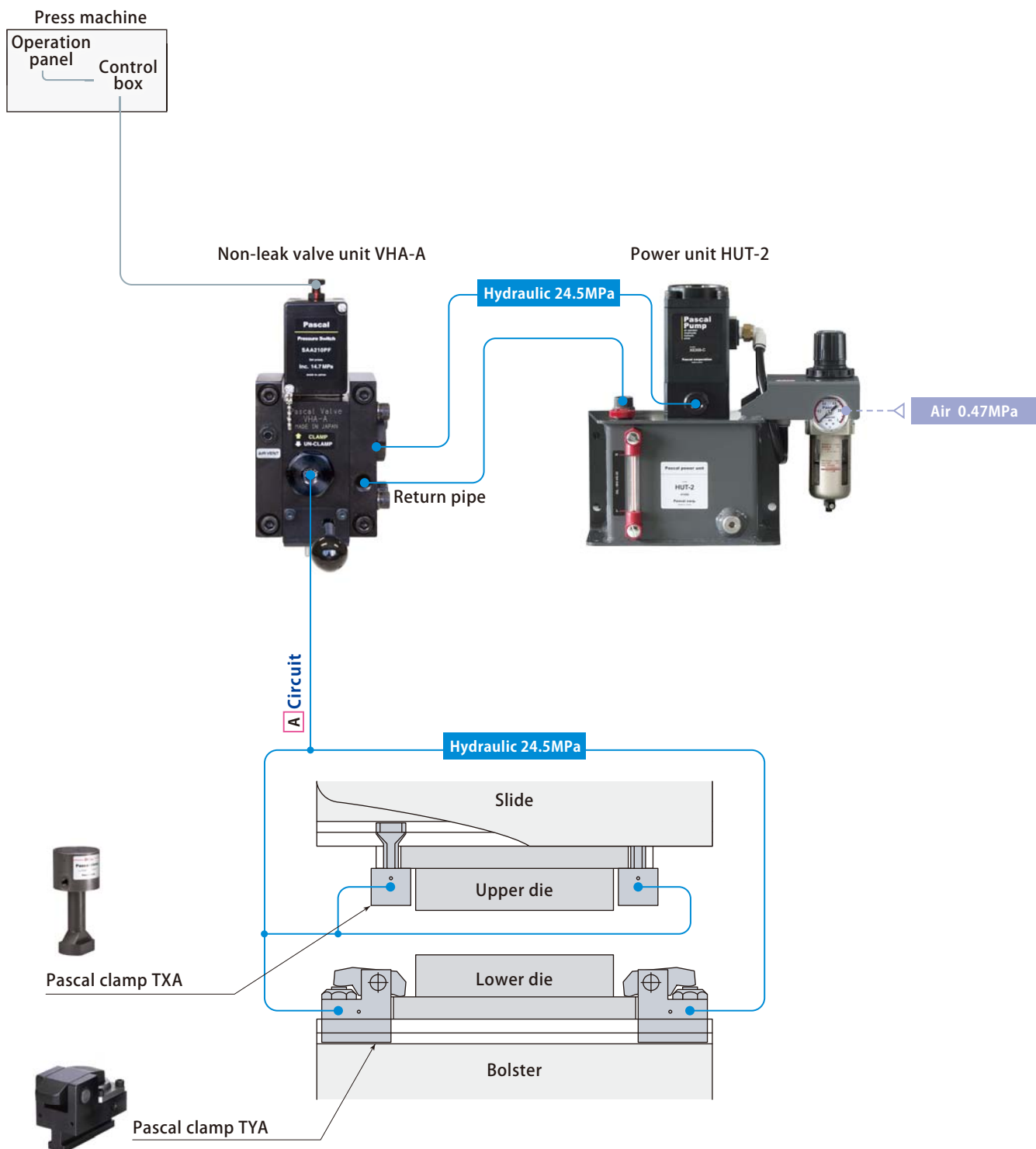

Control system
Example of hydraulic circuit

B Circuit

Number of hydraulic circuits		
Upper clamp	Lower clamp	Die-lifter
—	—	1

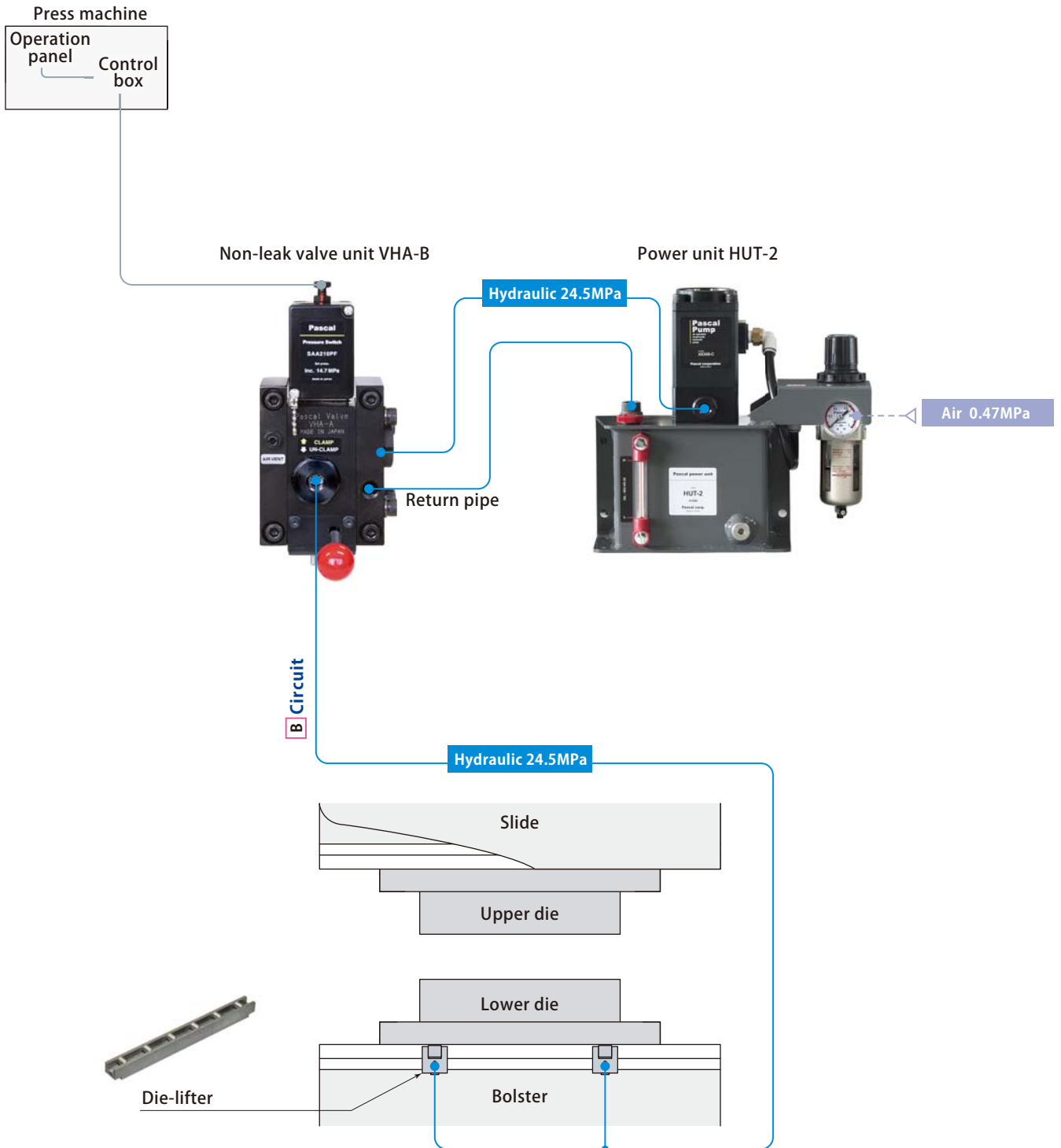

Control system
Example of hydraulic circuit

A C Circuits
 (**C = A + B Circuits**)

Number of hydraulic circuits		
Upper clamp	Lower clamp	Die-lifter
1	1	1

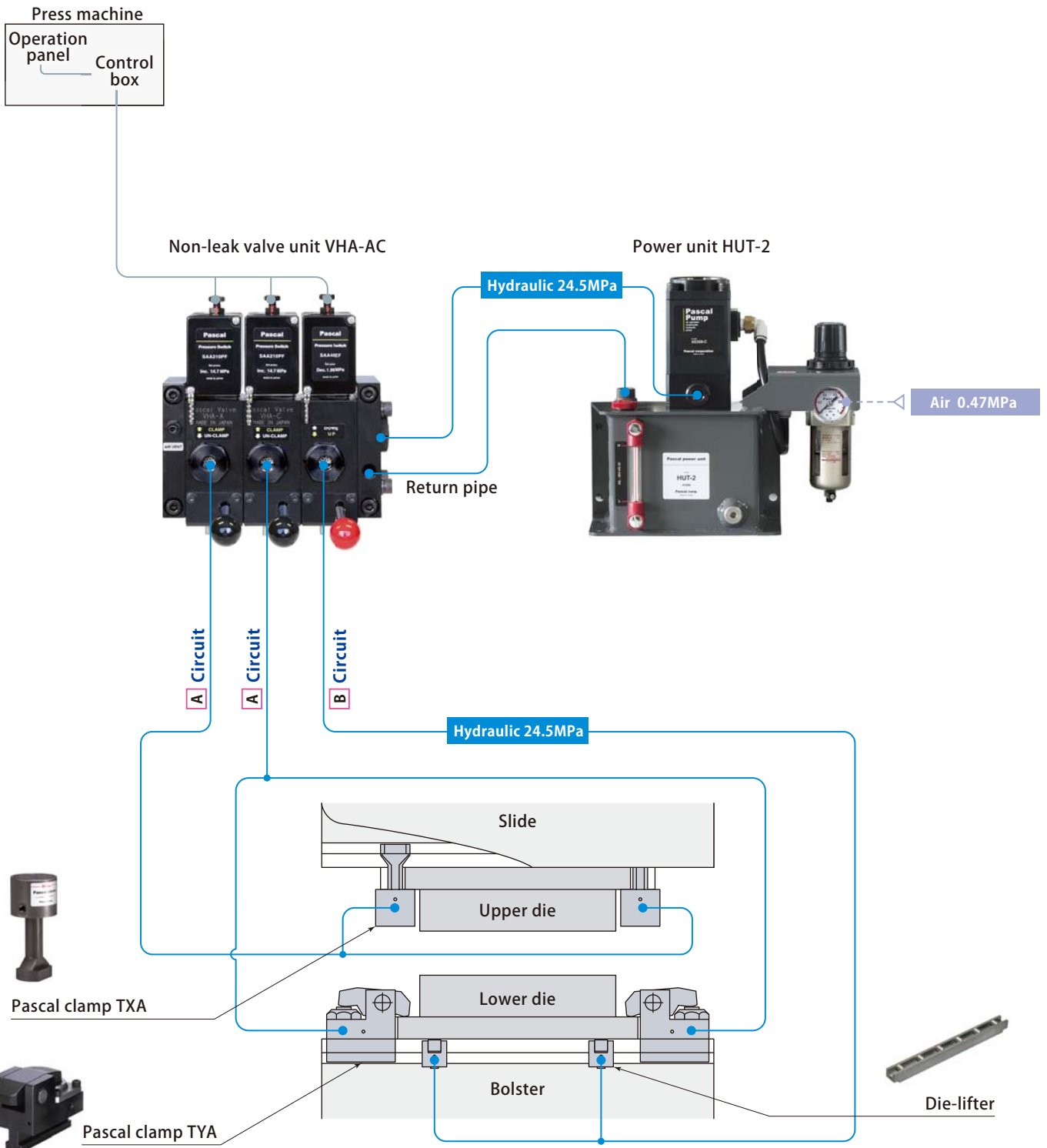

Control system
 Example of hydraulic circuit

DDF Circuits

Number of hydraulic circuits		
Upper clamp	Lower clamp	Die-lifter
1	1	—

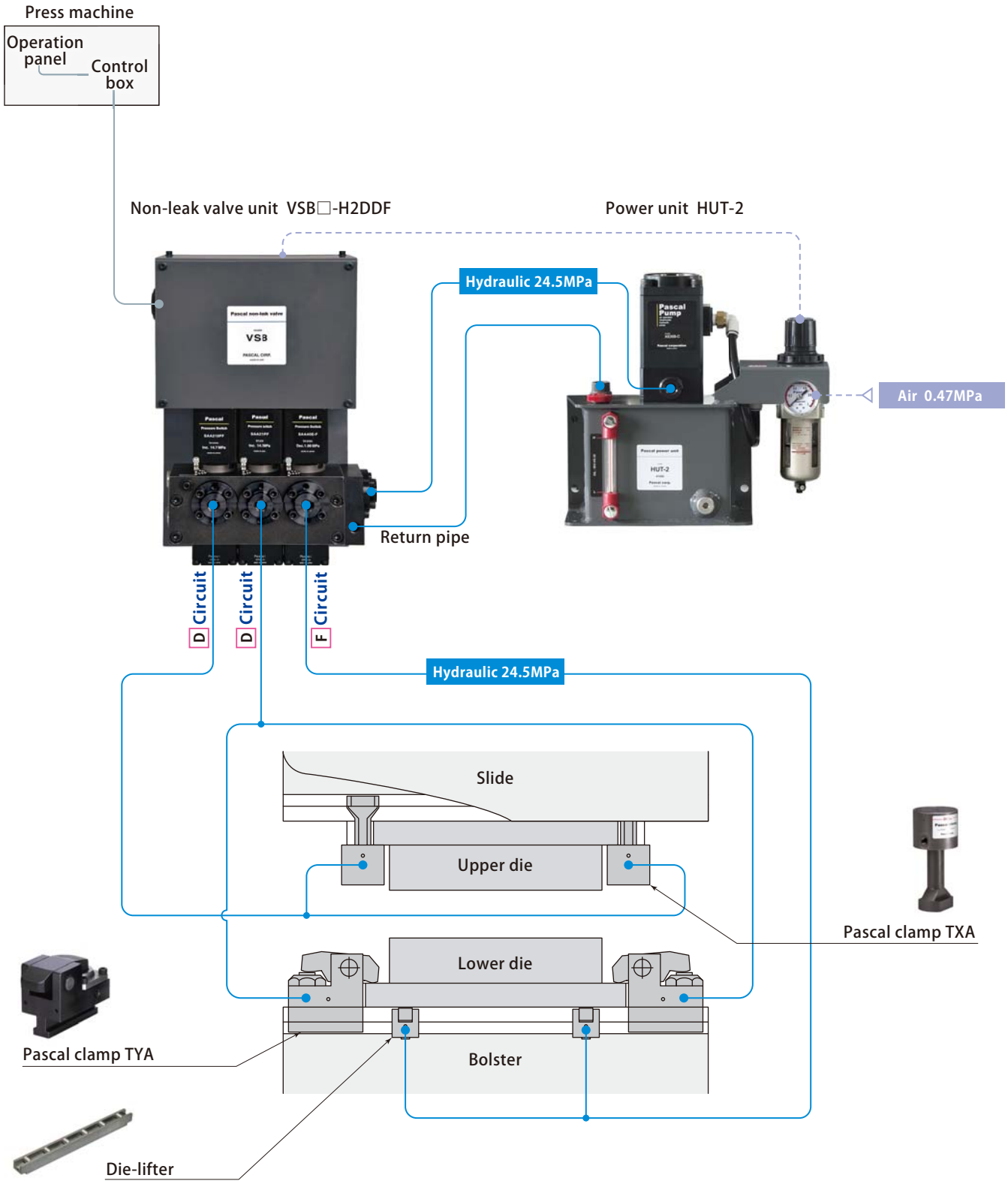

Control system
Example of hydraulic circuit

DD Circuits

Number of hydraulic and air circuits				
Upper clamp		Lower clamp		Die-lifter
Hydraulic pressure	Air	Hydraulic pressure	Air	Hydraulic pressure
1	1	1	1	—

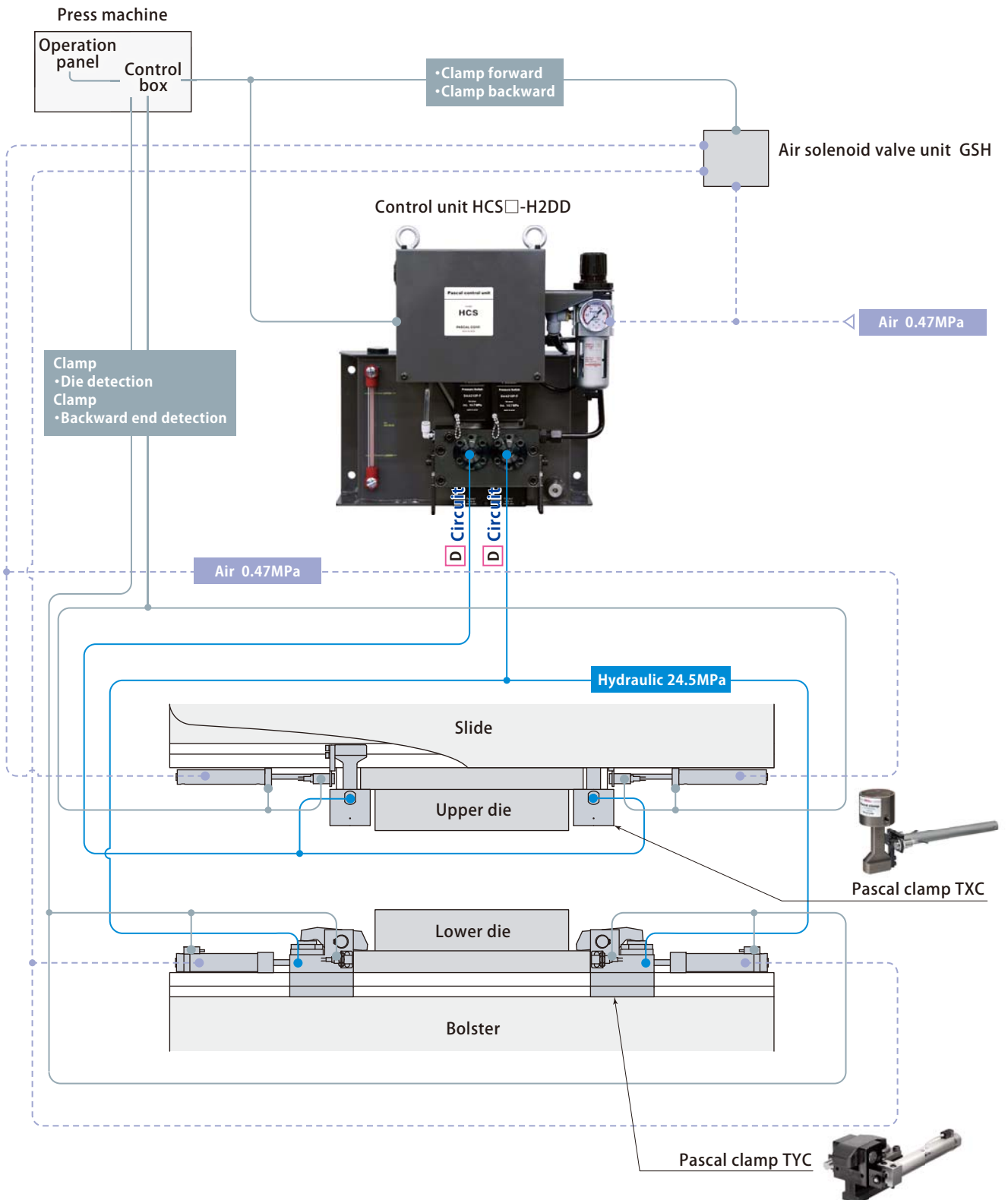

Control system
Example of hydraulic circuit

D D F Circuits

Number of hydraulic and air circuits				
Upper clamp		Lower clamp		Die-lifter
Hydraulic pressure	Air	Hydraulic pressure	Air	Hydraulic pressure
1	1	1	1	1

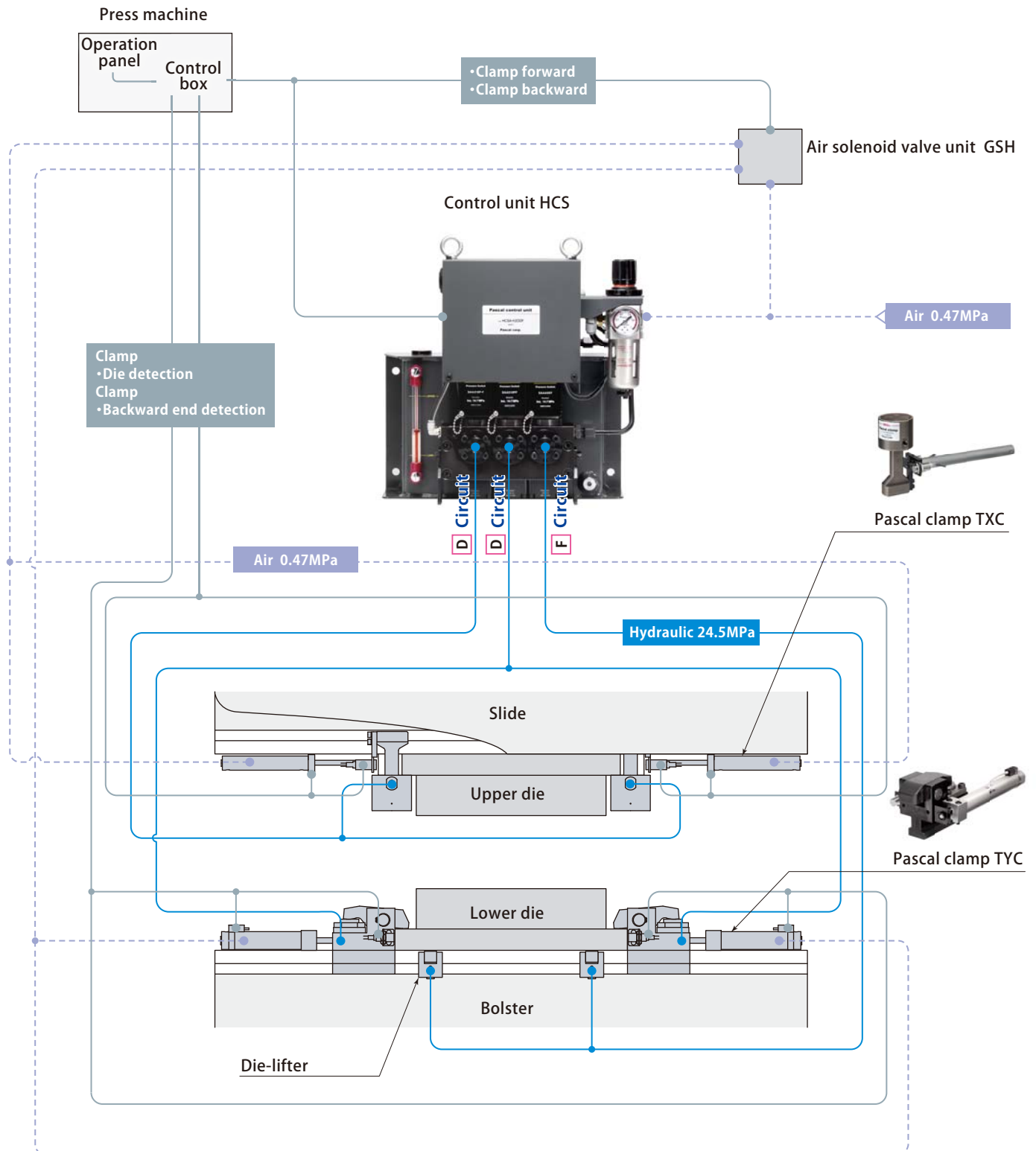

Control system
Example of hydraulic circuit